

Revision:

Version	Date	Revised Contents
1.1	May 2018	Added wiring section for wiring details, precautions and recommendations for Header as well as for IO modules. Updated sub-section "IO data" under Header M-CCB-H and M-MT-H. Added number of variants under digital IO, Analog IO modules and System modules
1.2	June 2018	Added ordering information and current consumption for available modules. Added sub-section "Parameter setting and IO data Monitoring" for explaining special features under Modular IO Configurator.
1.3	July 2018	Added list of "CC-Link IE Field Basic network specific diagnostics" and "Modbus TCP network specific diagnostics" under respective Header sections.
1.4	August 2018	Added wiring description (label) under individual module section "Connection diagram". Added section "Troubleshooting"
1.5	October 2018	Added section 9. Special Function Modules → 2 CH serial COM Module [M-2R2] Updated sections for SD memory card (SDHC) support. 2. Installation 4. Modular IO Configurator and 5. Header Modules
1.6	October 2018	Added feature "Enquiry" in Modular IO Configurator section.
1.7	November 2018	Added information of module (M-AD4) (4 Ch. V/ I Analog Input Module)
1.8	January 2019	Added information of module (M-1R2) (1 Ch. Serial COM (RS232) Module)
1.9	January 2019	Added information of Header module M-EIP-H (Ethernet/ IP Header module)
1.10	June 2019	Added information of module (M-ADV8) (8 Ch. Analog Voltage Input Module) Added information of module (M-ADI8) (8 Ch. Analog Current Input Module) Added "Special Features → Module Versions" in chapter 4. Modular IO Configurator.
1.11	July 2019	Added ODVA conformance information for M-EIP-H (Ethernet/IP™ Header module). Added CE approval specification.
1.12	August 2019	Added "Special Features → Unknown Module" in chapter 4. Modular IO Configurator. In 9.1 M-2R2 and 9.2 M-1R2, added firmware and configurator tool version support note.
1.13	November 2020	Updated specification for M-DA2 (2 Ch. Analog Voltage/ Current Output Module)
1.14	June 2021	Added information of module (M-DA4) (4 Ch. V/ I Analog Output Module)
1.15	January 2022	Modified specification "Overall accuracy" for M-DA4 Change in dimensional details of Header module and IO module.
1.16	March 2023	Added information of module (M-TCRT4) (4 Ch. Thermocouple/ RTD Input Module) Updated section 'Overview → Ordering Information' to add information of modules with conformal coating.
1.17	July 2023	Updated information of module (M-ADV8) (8 Ch. Analog Voltage Input Module) for additional input range support of 0 to 5 VDC. Updated specification for module (M-TCRT4) (4 Ch. Thermocouple/ RTD Input Module)
1.18	Dec 2023	Updates related to compliance. Updated isolation specifications for M-CCB-H, M-MT-H, M-EIP-H and M-SPE.
2.00	July 2024	Added information of module (M-1R4) (1 channel serial RS422/ RS485 communication module) Added information of header assembly modules - M-B2, M-B3, M-B5 - M-CCIEF-H - M-APSU - M-DPSU - M-ADP - M-BC
2.01	Oct 2024	Updated sections below - Section 5.5, File copy from Header to SD card - Section 3 Recommendations and Precautions - Section 6.1 to 6.6, 7.6, 7.7 Specifications - Section 10, Error code - Section 1 and 2 Added

		<ul style="list-style-type: none">- Section 1, Approvals: EU Directives and Standards- Section 5.5 information of module (M-CCIEF-H) (CC-Link IE TSN Header Module)
--	--	--

Intended audience of this manual

Thank you for choosing the Mitsubishi Electric India product.

Do not use this product until you have full knowledge of the equipment. Please forward this manual to end user.

This manual is intended to the following personnel,

- Managing in charge.
- Designing or developing personnel.
- Commissioning and maintaining personnel.
- Supervising personnel.
- Operating personnel.

Scope of manual

This user manual provides the following details of Modular IO product.

- List of Header modules, IO modules, system modules and special function modules.
- Guidelines for installation and wiring.
- Features and specifications of all types of modules.
- Configuration details.
- Status and diagnostic information.
- Maintenance and troubleshooting.

Important information for user





Read and understand the manual carefully before using Modular IO product, to avoid any damages to persons, properties or environment. Ensure safe and proper usage of this Modular IO product.

Do not modify, dismantle, re-construct and repair the electronic modules. For repair, contact nearest authorized sales office or technical support team.

Qualified and properly trained personnel should only install the Modular IO product. The personnel should be aware of all the safety aspects of automated products and completely familiar with all associated documentation for the said Modular IO product.

Protect Modular IO product from conductive dust, corrosive gases, wire debris, flammable gases, rain and fluid entering into the Modular IO product through ventilation slits, this may cause malfunctioning, damage, fire, electric shock and deterioration.

List of Symbols

	This symbol indicates that the specified operation/s is/are mandatory or must to do or the precautions are mandatory.
	This symbol indicates warnings, specifically related to the electric shocks and hazards.
	This symbol indicates cautions for critical situations, which may cause accidents or serious injury or may be severe property damage. This covers general warnings as well as cautions.
	This symbol indicates or covers operations that user must to avoid. This is specifically related to disassembly of product.
NOTE	This symbol indicates points to note or to consider during usage of said product. Also, indicates summary of individual sections covered in this manual.

Terms and Conditions

- Mitsubishi Electric India Pvt. Ltd. shall have no responsibility or liability for any personnel injury or death, or loss or damage to the property caused by said product, if used or operated in applications which are not intended or excluded by instructions, precautions or warnings provided in this document for the said product.
- Specifications are subject to change without prior notice.
- The reproduction or transmission of this document or its contents in full or part is not allowed without written permission from the authority.

Precautions for safe use of product

- Disconnect all power supplies before performing installation and wiring work.
- For mains power supply connections, confirm suitable fuse is used.
- Do not touch the conductive part directly. This may cause malfunctioning of product or electric shock.
- Do not bundle IO wires, 24 Vdc wires with main control panel wiring together.
- Consider maximum rated current and inrush current of power supply module while selecting 24 Vdc power supply source. Ensure that external breaker or fuse used in series with 24 Vdc.
- Confirm that the source of voltages and currents are within specified ranges.
- Connect functional earth terminal properly. If not, product may be susceptible to the noise.
- Connect protective earth terminal to a good quality earth. If not, it may result in electric shock or erroneous operation.
- If this product emits smoke or an unusual odor or unusual sound or unusual operation, immediately switch OFF the power to the product. This may result in fire and damage the product. In such cases, contact the nearest authorized sales or service support team.

Disposal precaution

- Treat the said product/s as an industrial E-waste.
For environmentally compliant recycling and disposal of your electronic waste, please contact to certified agency.

Recommendations for safe use of product

- It is always recommended to route cables carrying low level signals e.g. analog IO signals, serial communication signals, Ethernet communication cables separately and away from cables carrying high voltage and large current signals.
- It is recommended to connect cable shield to the ground terminal at the IO module end and leave it unconnected at the device (sensor/actuator) end.

Replacement Cycle

- Although it depends on the status of use, 10 years is the guideline for renewal.

INDEX

- 1** [Overview](#)
 - 2** [Installation](#)
 - 3** [Wiring](#)
 - 4** [Modular IO Configurator](#)
 - 5** [Header modules](#)
 - 6** [Digital IO modules](#)
 - 7** [Analog IO modules](#)
 - 8** [System modules](#)
 - 9** [Special Function Modules](#)
 - 10** [Troubleshooting](#)
-

[Back To Index Page](#)

1 Overview

[Modular IO System](#)

[Nomenclature](#)

[Ordering Information](#)

[Environmental Specifications](#)

[Approvals: EU Directives and Standards](#)

Modular IO System

Modular IO system supports two types of Modular IO stations,

- **Modular IO station with Header** consists of a Header module with one or more IO modules and system modules attached to it as per the application requirement.
- **Modular IO station with Header assembly** consists of a 'header assembly' with one or more IO modules and system modules attached to it as per the application requirement.

Header assembly is introduced to support hot swapping for header module and power supply modules. Header assembly includes a base module which holds modules like power supply module, header module and I/O adapter module.

Modular IO Station with Header Module:

Modular IO station is a fieldbus/network slave station and Header module acts as an interface between fieldbus/network master and the IO modules attached to itself.

There is no separate base module required to mount other modules. All the modules are directly mounted on standard DIN rail (35 x 7.5 mm). When IO modules are attached to a Header module on a DIN rail, backplane interface (along with system power supply and field power supply) is formed by pins and receptacles interface between the modules. Hot swapping is not supported because removal of any intermediate module discontinues backplane interface for modules on its right side.

Variety of digital IO modules, analog IO modules, system modules and special function modules are available to choose from. PC based "Modular IO Configurator" is used to configure modular IO station. The figure below shows modular IO station.

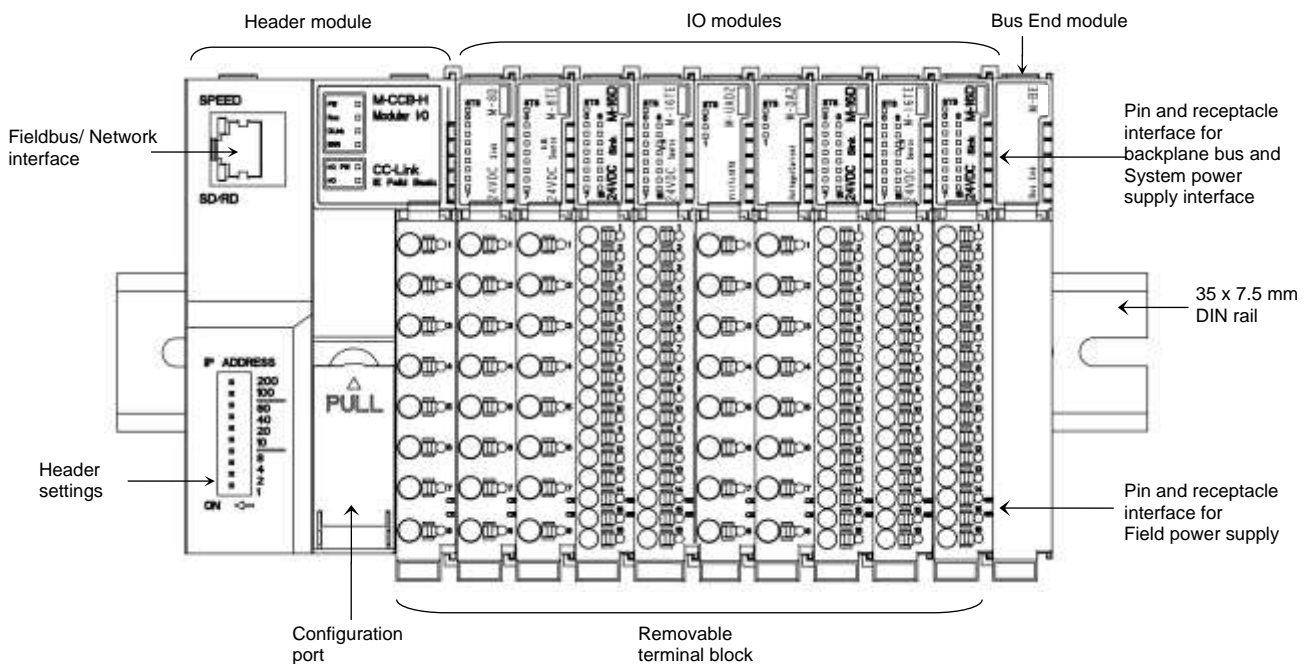

This user manual provides nomenclature and dimensional details of all the modules, installation and wiring along with general and module specifications.

Additionally, it provides the procedure to configure the modules and to monitor its diagnostics using PC based Modular IO Configurator.

Modular IO Station with Header Assembly:

Modular IO station is a fieldbus/network slave station. Header module mounted on base module acts as an interface between fieldbus/network master and the IO modules attached to header assembly.

Base module can be mounted on standard DIN rail (35 x 7.5 mm). Other header assembly modules are mounted on base module in designated slots. This arrangement supports hot swapping for redundant power supply and redundant Header modules. The rightmost module of the header assembly acts as an adapter which allows attachment of I/O modules to Header assembly.

Variety of digital IO modules, analog IO modules, system modules and special function modules are available to choose from. PC based "Modular IO Configurator" is used to configure header assembly and I/O modules.

Base modules are available with different number of slots. The figure below shows 5-slots header assembly.

5-slots header assembly consists of up to two AC input power supply modules, two Header modules and one I/O adapter module. This system can be used for redundant operation of power supply module or header module or both.

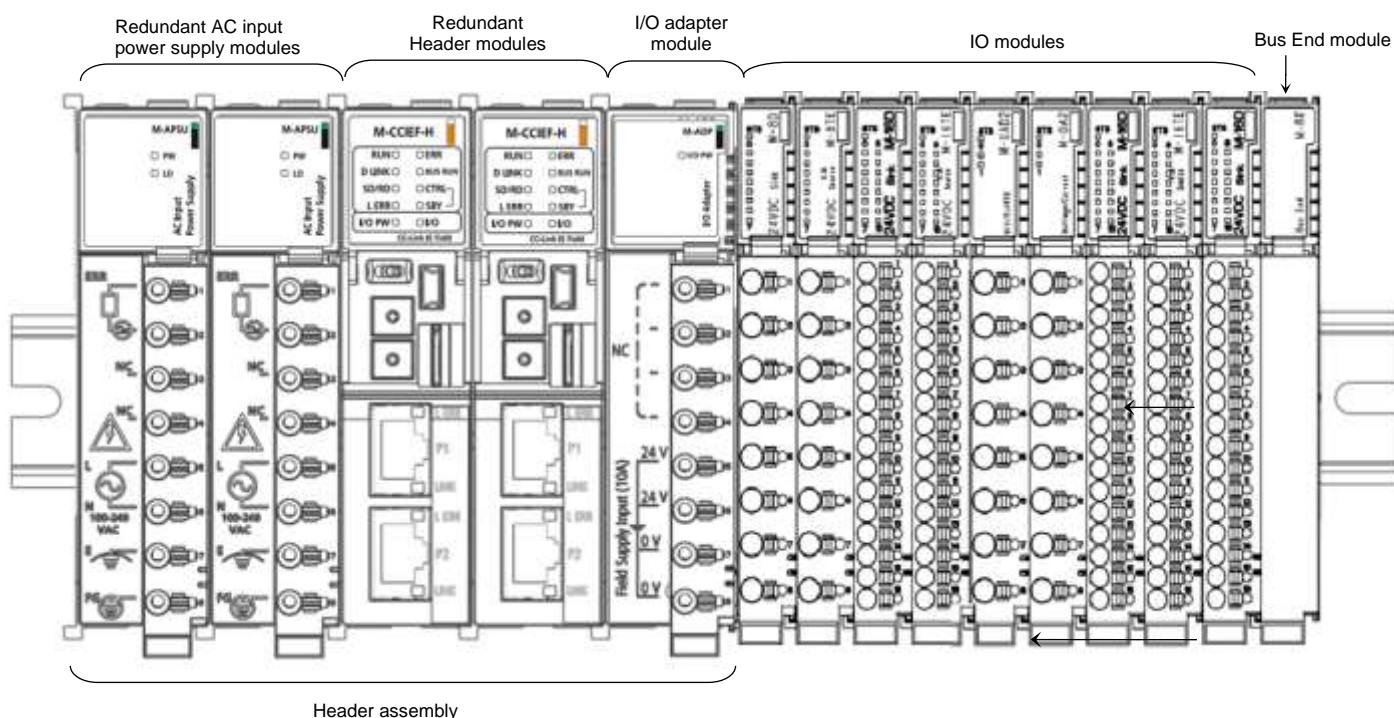

3-slots header assembly consists of one AC input power supply module, one Header module and one I/O adapter module.

2-slots header assembly consists of one Header module and one I/O adapter with DC input power supply module.

NOTE

For 5-slot header assembly, following configurations are also possible

- Configuration with single power supply and two header modules.
- Operation with single header module and two power supply modules.

Install blank cover 'M-BC' in unused slot.

Nomenclature

This section provides nomenclature details for Header module, IO module and terminal block.

Header modules: M-CCB-H, M-MT-H, M-EIP-H

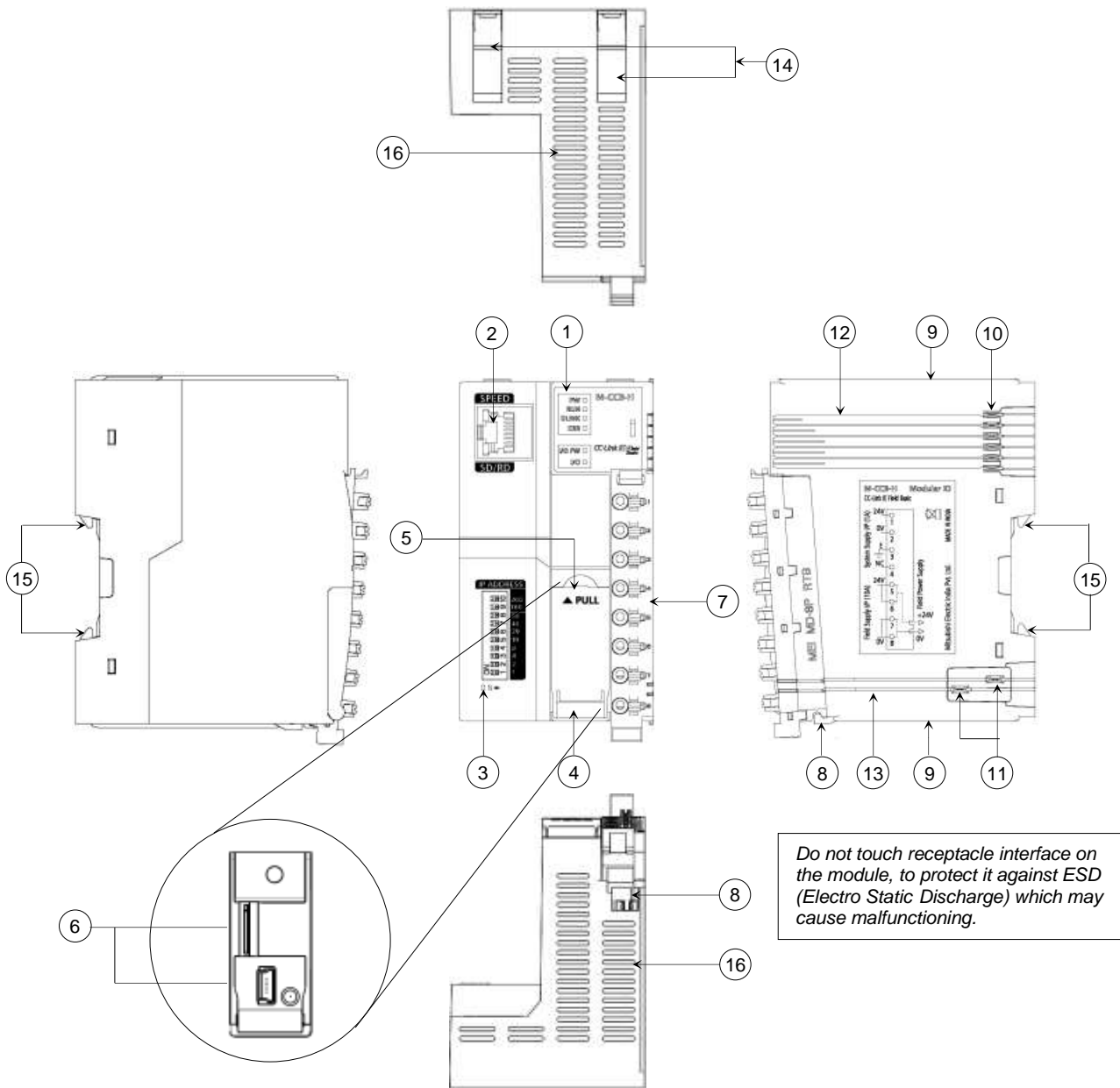

No.	Description	No.	Description
1	LED indications	9	Guide at top and bottom side for IO module attachment in next I/O slot
2	Fieldbus/ Network interface	10	6 Receptacles for System power supply interface
3	Header settings	11	2 Receptacles for Field power supply interface
4	Door with hinge for USB Interface	12	Grooves for System power supply interface
5	Notch to open the door	13	Grooves for Field power supply interface
6	SD card slot push button and USB interface	14	2 DIN clamp levers
7	8 Point terminal block *	15	4 DIN clamp holders
8	Hinge support for terminal block	16	Air vents at top and bottom side

*Refer section "[8 and 16 Point terminal Block](#)" for nomenclature for terminal block.

IO Module With 16 Point Terminal Block: M-16D, M-16DE, M-16TE, M-AD4, M-ADI8, M-ADV8, M-TCRT4

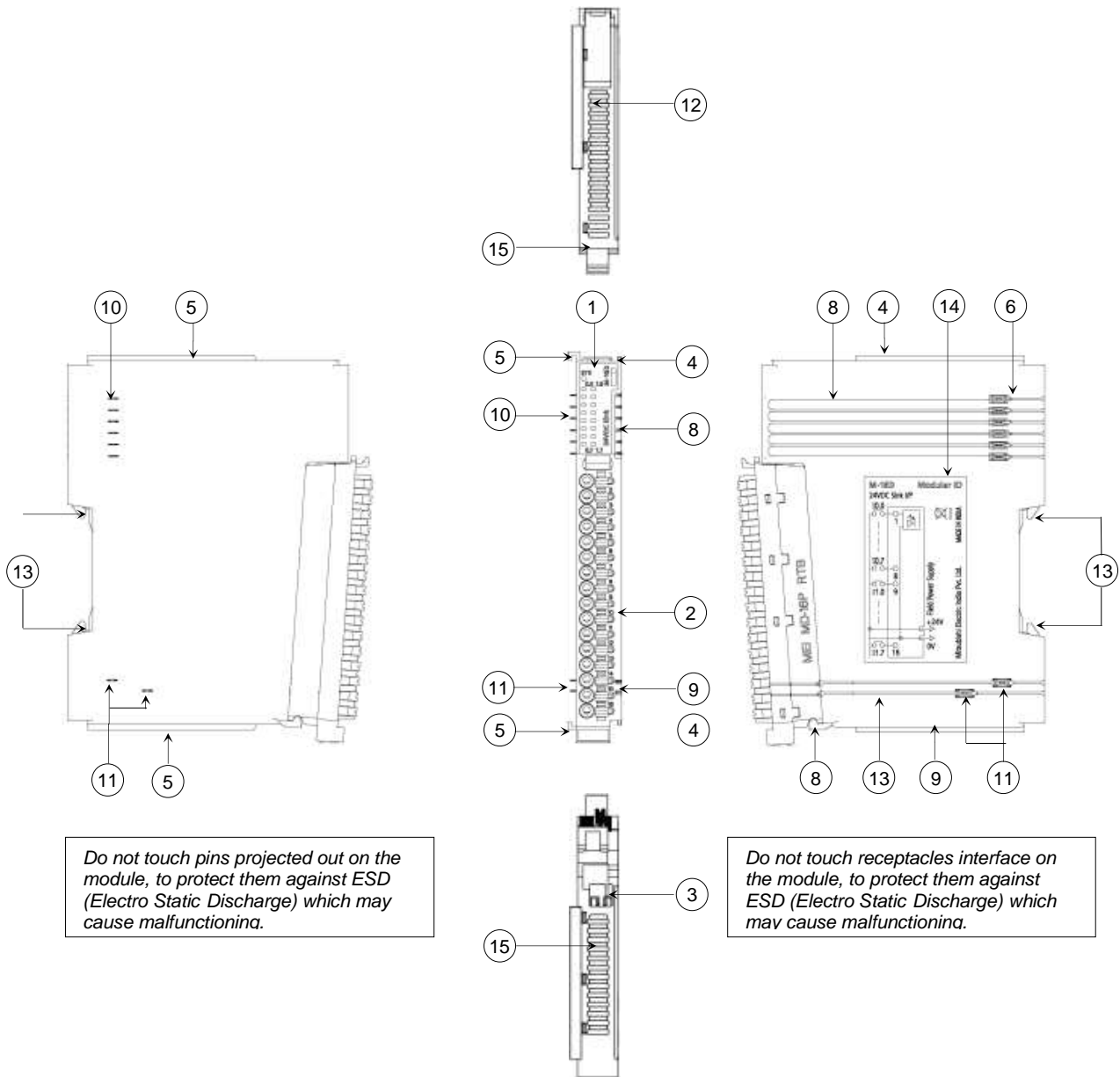

No.	Description	No.	Description
1	LED indications	9	Grooves for Field power supply interface
2	16 Point terminal block*	10	6 Pins for System power supply interface
3	Hinge support for terminal block	11	2 Pins for Field power supply interface
4	Guide at top and bottom side for module attachment in next slot	12	1 DIN clamp levers
5	C slot at top and bottom side for module attachment in previous slot.	13	2 DIN clamp holders
6	6 Receptacles for System power supply interface	14	Wiring label
7	2 Receptacles for Field power supply interface	15	Air vents at top and bottom side
8	Grooves for System power supply interface		

*Refer section "[8 and 16 Point terminal Block](#)" for nomenclature for terminal block.

IO Module With 8 Point Terminal Block: M-4D, M-DE, M-8D, M-8DE, M-4TE, M-8TE, M-UAD2, M-DA2, M-DA4, M-1R2, M-1R4, M-2R2, M-FPD, M-FPI, M-SPE, M-ST

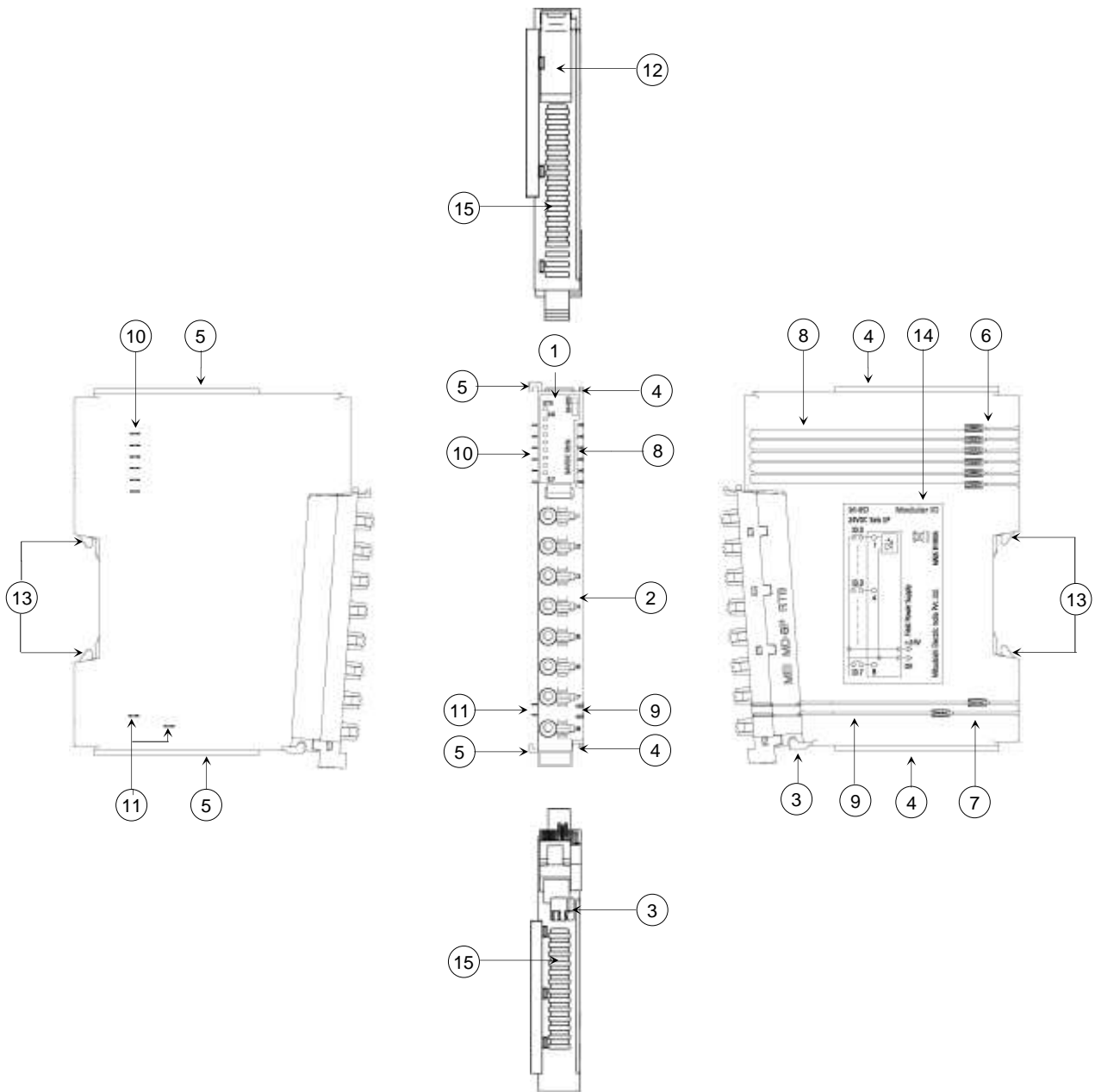

No.	Description	No.	Description
1	LED indications	9	Grooves for Field power supply interface
2	8 Point terminal block *	10	6 Pins for System power supply interface
3	Hinge support for terminal block	11	2 Pins for Field power supply interface
4	Guide at top and bottom side for module attachment in next slot	12	1 DIN clamp levers
5	C slot at top and bottom side for module attachment in previous slot.	13	2 DIN clamp holders
6	6 Receptacles for System power supply interface	14	Wiring label
7	2 Receptacles for Field power supply interface	15	Air vents at top and bottom side
8	Grooves for System power supply interface		

*Refer section "[8 and 16 Point terminal Block](#)" for nomenclature for terminal block.

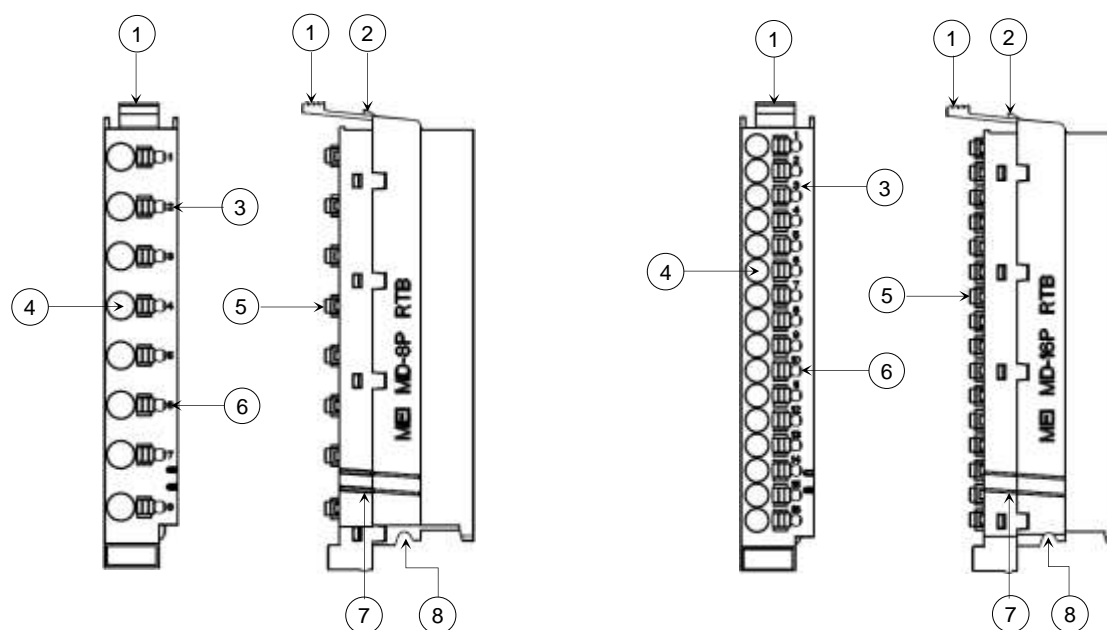
8 Point and 16 Point terminal block:

No.	Description	No.	Description
1	Latch	5	Push buttons
2	Notch for locking with module enclosure	6	Test points for signal voltage measurement
3	Terminal number	7	Grooves for Field power supply interface
4	Wire insertion points	8	Round groove to align with hinge support on module

NOTE

Current carrying capacity of 8 point and 16-point terminal block is 5 A and 2 A respectively.
Terminal block complies for the Pull-out test according to IEC/EN 60947-7-1, IEC/EN 60998-2-2, IEC/EN 60999-1.

2-Slots Base Module: M-B2

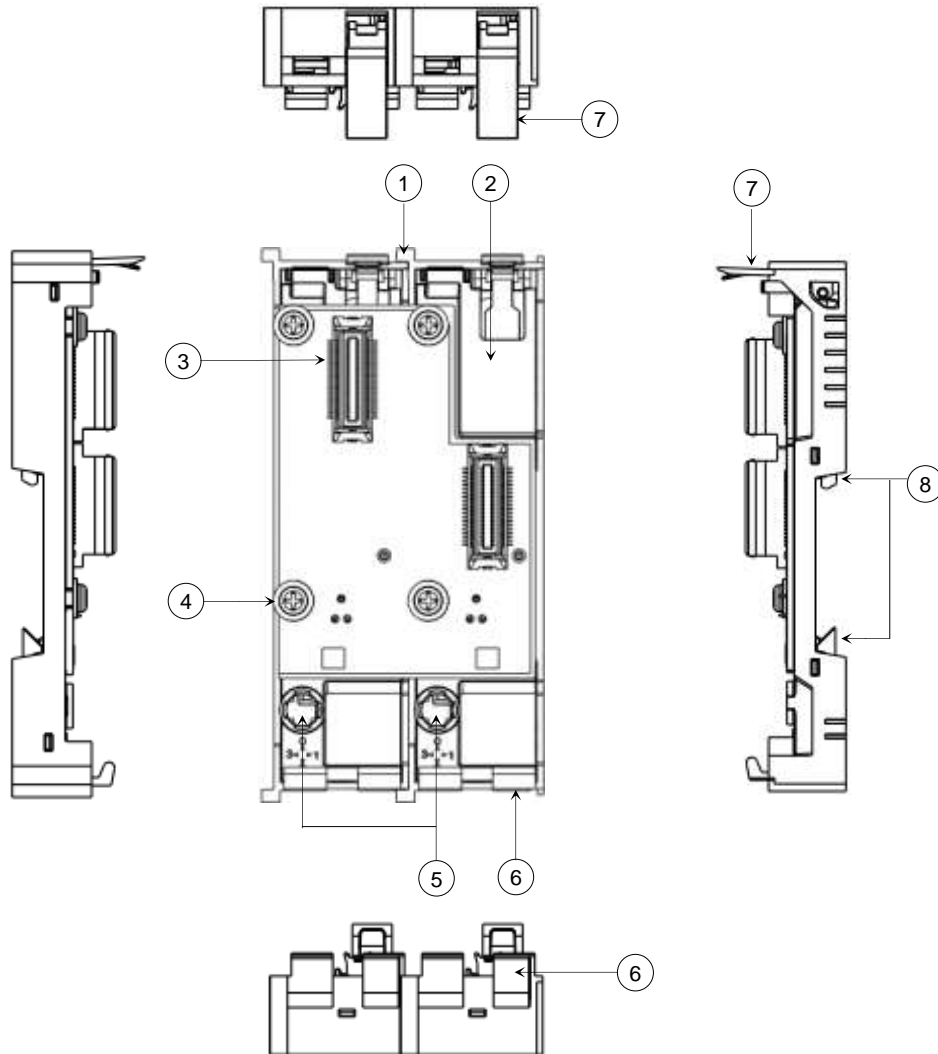

No.	Description	No.	Description
1	Base housing	5	Slot coding parts
2	Backplane PCB	6	Module bottom rest
3	Module interface connectors	7	DIN clamp lever
4	Backplane PCB fixing screws	8	DIN clamp holders

2-slots base module holds one Header module and DC input power supply module.

3-Slots Base Module: M-B3

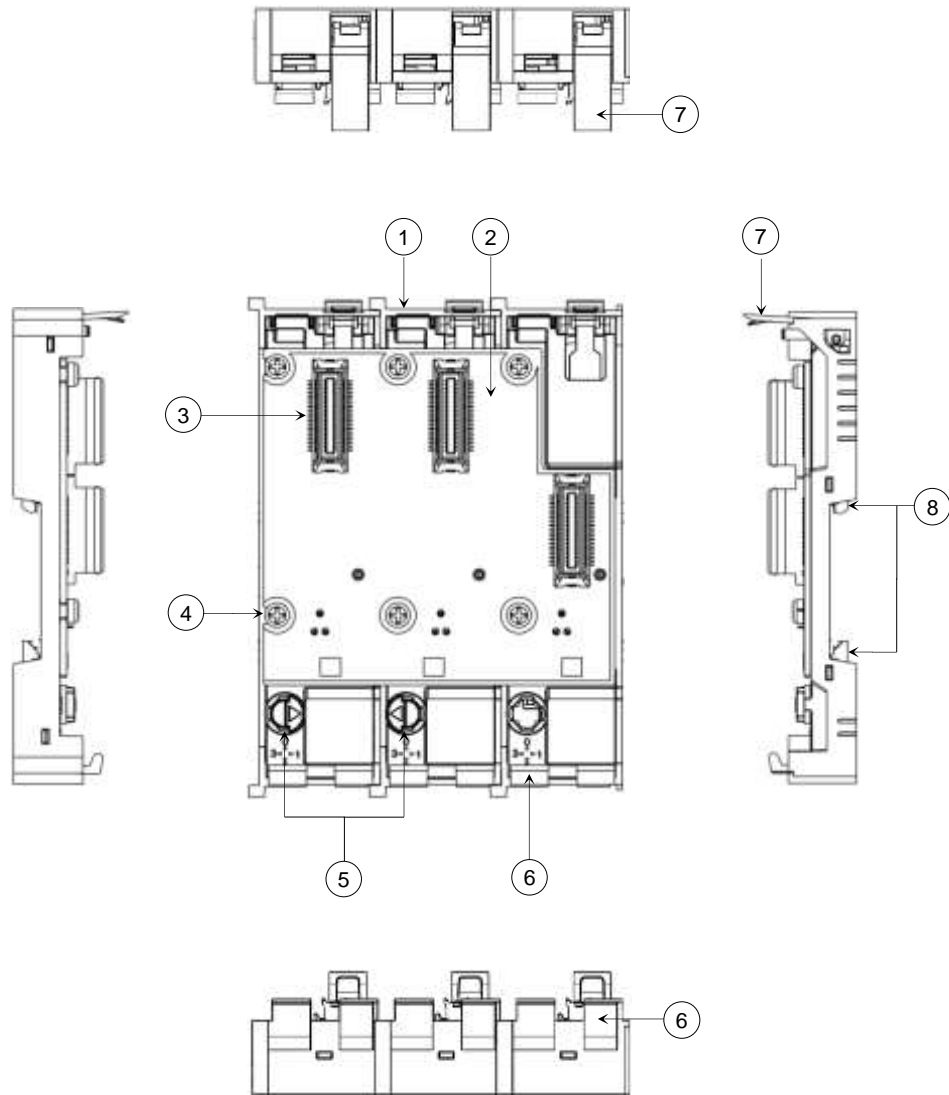

No.	Description	No.	Description
1	Base housing	5	Slot coding parts
2	Backplane PCB	6	Module bottom rest
3	Module interface connectors	7	DIN clamp lever
4	Backplane PCB fixing screws	8	DIN clamp holders

3-slots base module holds one AC input power supply module, one Header module and one I/O adapter module.

5-Slots Base Module: M-B5

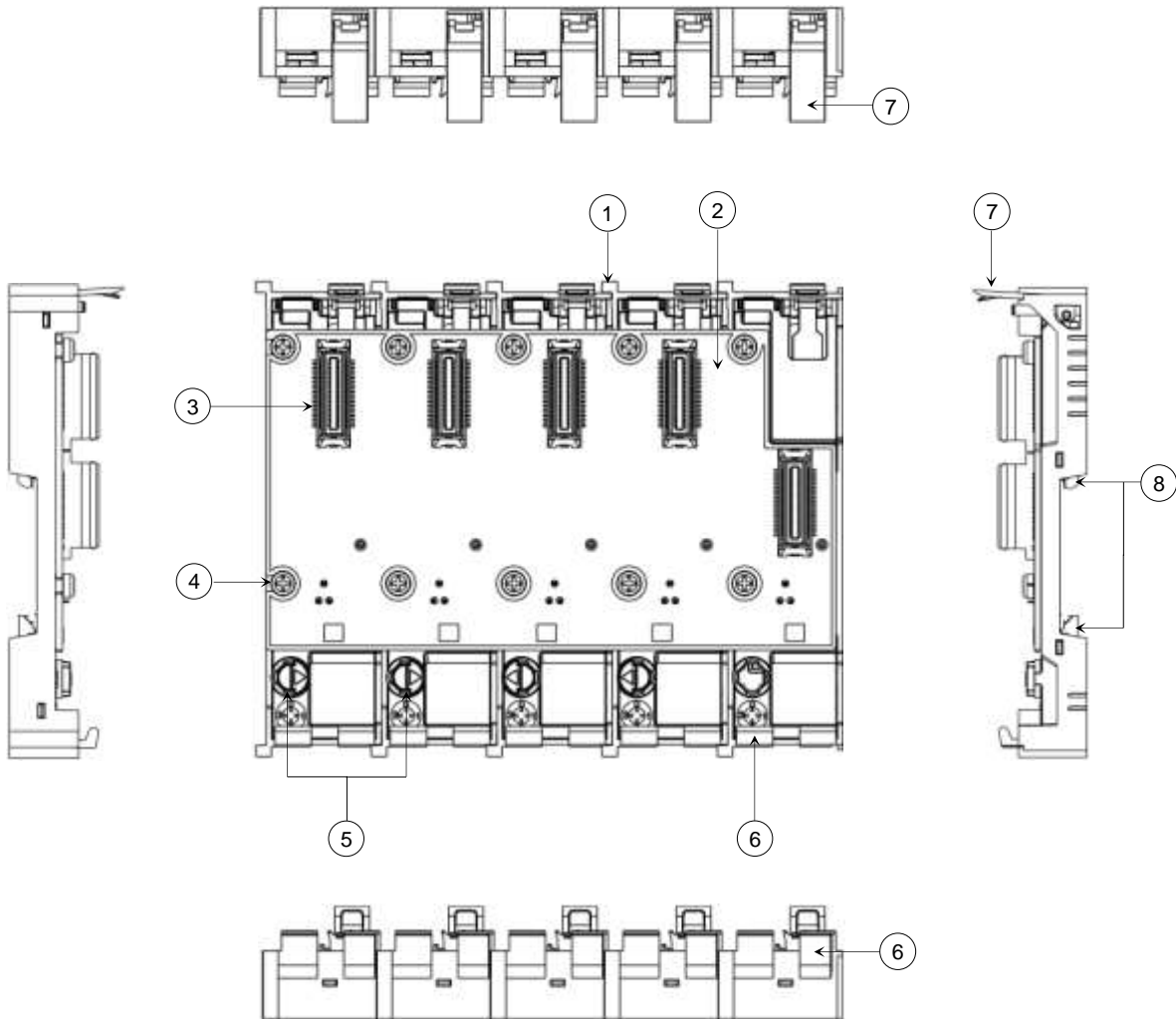

No.	Description	No.	Description
1	Base housing	5	Slot coding parts
2	Backplane PCB	6	Module bottom rest
3	Module interface connectors	7	DIN clamp lever
4	Backplane PCB fixing screws	8	DIN clamp holders

5-slots base module holds up to two AC input power supply module, two Header modules and one I/O adapter module.

Redundant AC Input Power Supply module: M-APSU

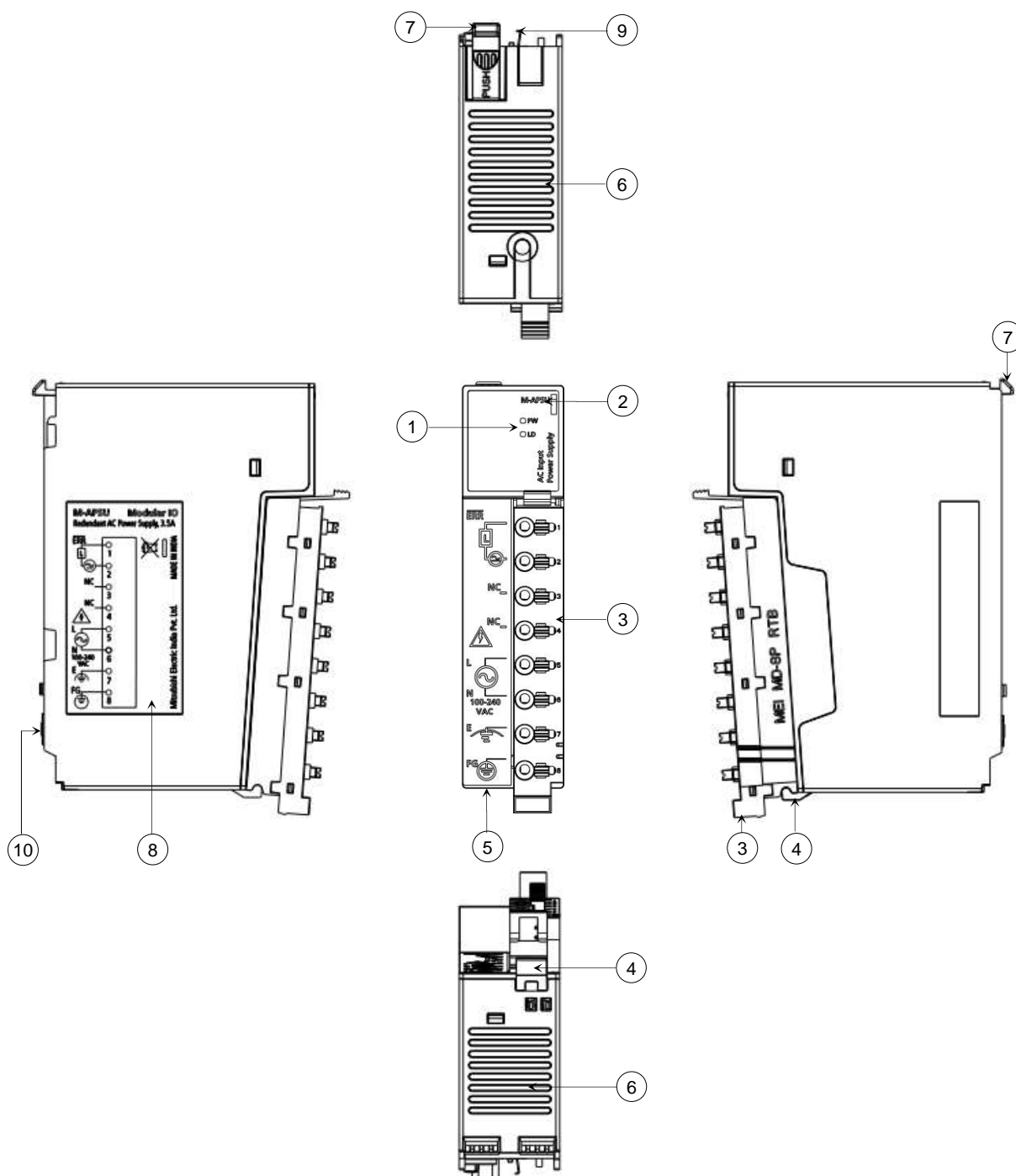

No.	Description	No.	Description
1	LED indications	6	Air vents at top and bottom side
2	Module ordering code	7	Module latch
3	8-point terminal block	8	Wiring label
4	Hinge support for terminal block	9	Earthing clip
5	Connection details	10	Coding part

24 VDC Input Power Supply module: M-DPSU

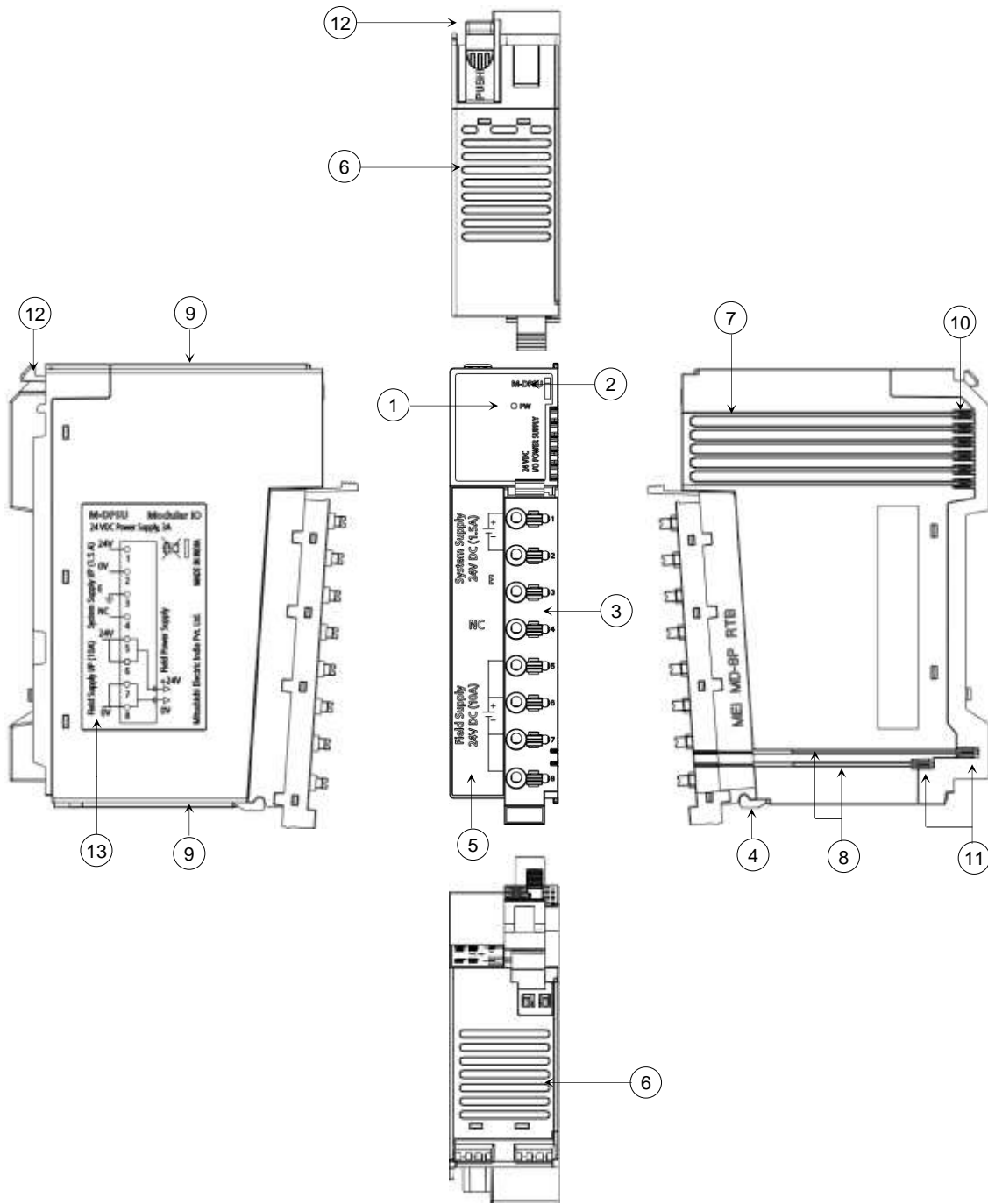

No.	Description	No.	Description
1	LED indications	8	Grooves for system power supply interface
2	Module ordering code	9	Guide at top and bottom side for IO module attachment in next slot
3	8 Point terminal block	10	6 Receptacles for system power supply interface
4	Hinge support for terminal block	11	2 Receptacles for field power supply interface
5	Connection details	12	Module latch
6	Air vents at top and bottom side	13	Wiring label
7	Grooves for field power supply interface		

Header module: M-CCIEF-H

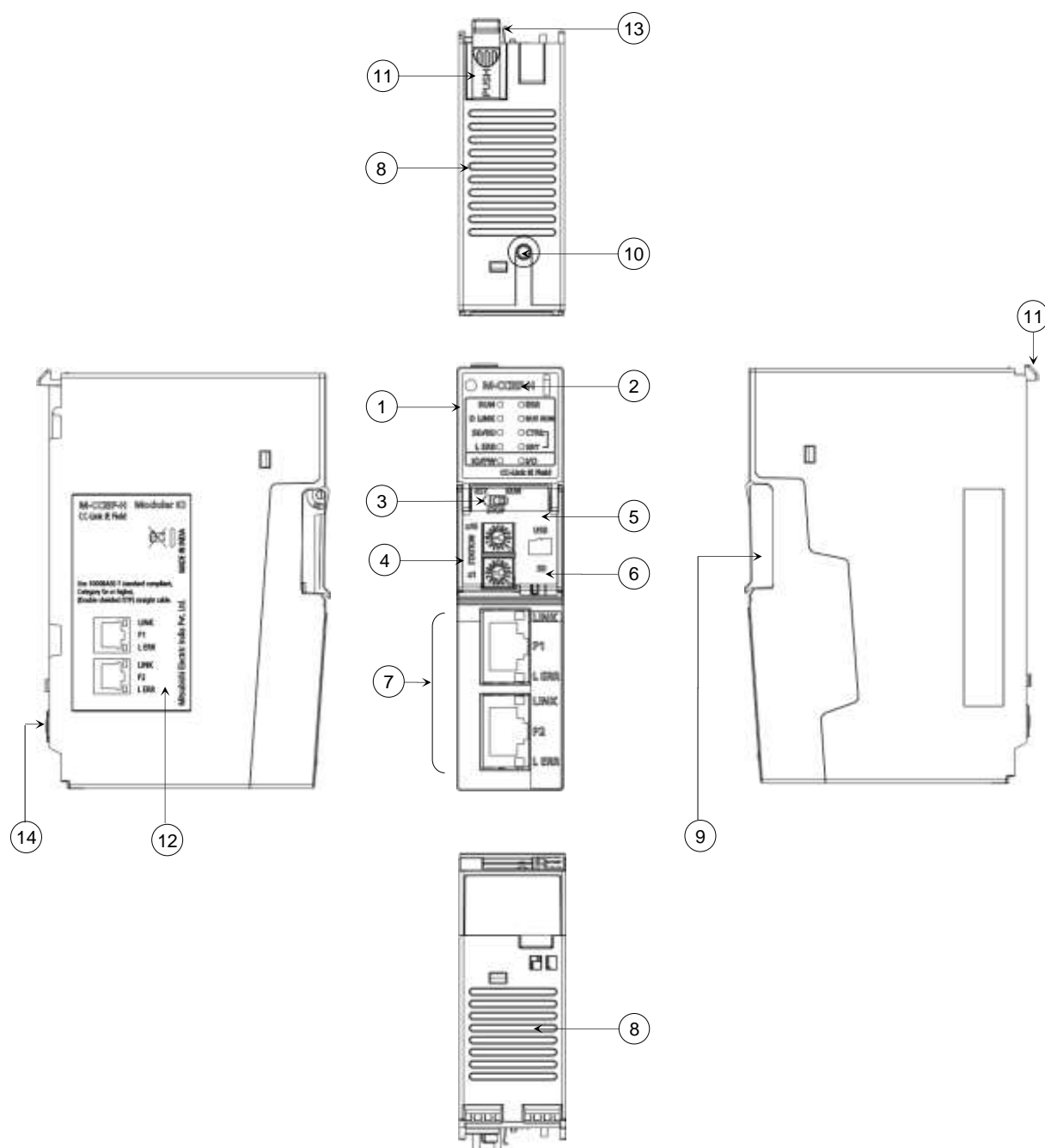

No.	Description	No.	Description
1	LED indications	8	Air vents at top and bottom side
2	Module ordering code	9	Front door
3	Operation mode switch	10	Push button for firmware update
4	Rotary switches for station number setting	11	Module latch
5	Mini USB 2.0 port	12	Wiring label
6	SDHC card socket	13	Earthing clip
7	Fieldbus/ Network interfaces	14	Coding part

I/O Adapter Module: M-ADP

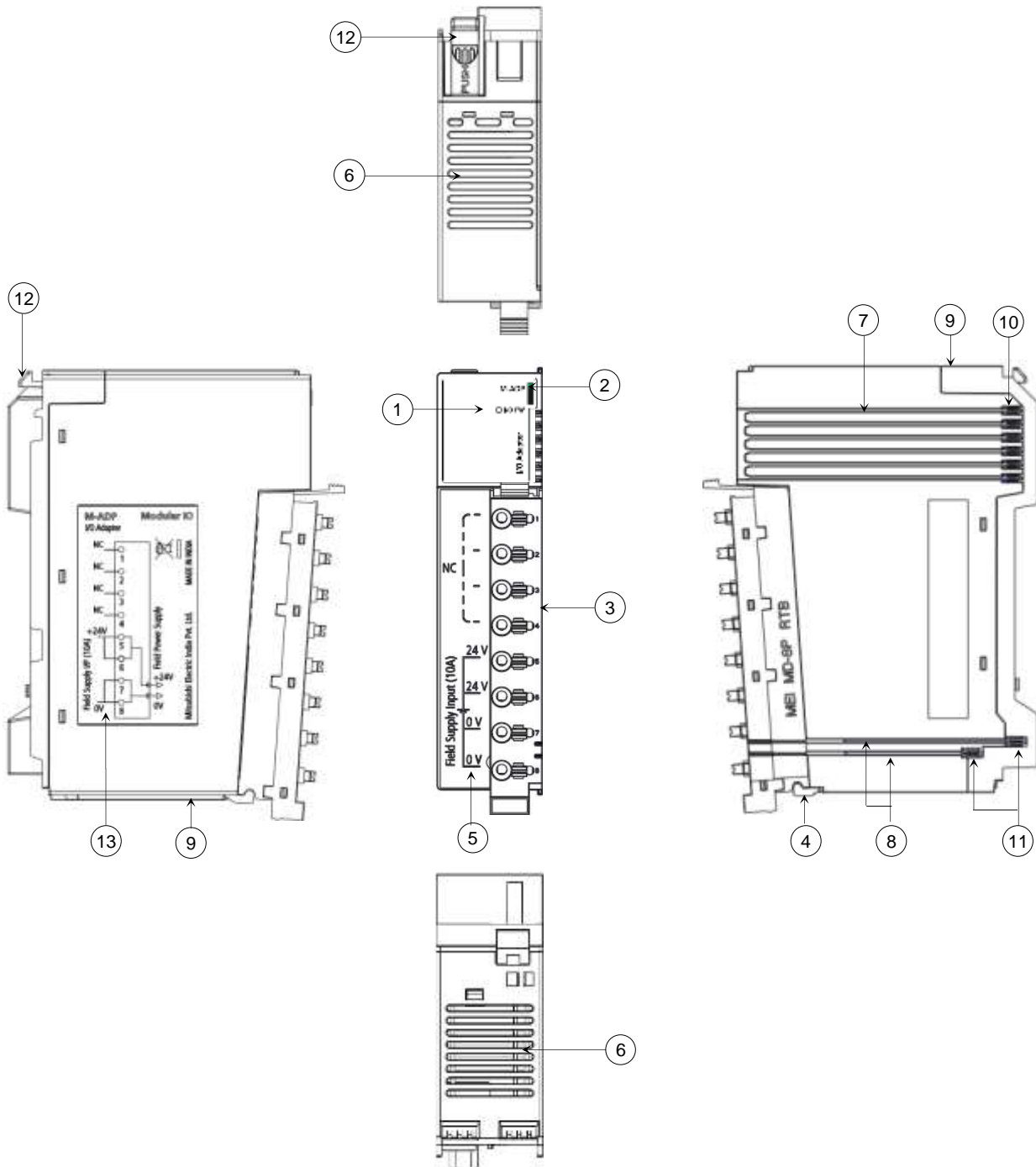

No.	Description	No.	Description
1	LED indications	8	Grooves for system power supply interface
2	Module ordering code	9	Guide at top and bottom side for IO module attachment in next slot
3	8 Point terminal block	10	6 Receptacles for system power supply interface
4	Hinge support for terminal block	11	2 Receptacles for field power supply interface
5	Connection details	12	Module latch
6	Air vents at top and bottom side	13	Wiring label
7	Grooves for field power supply interface		



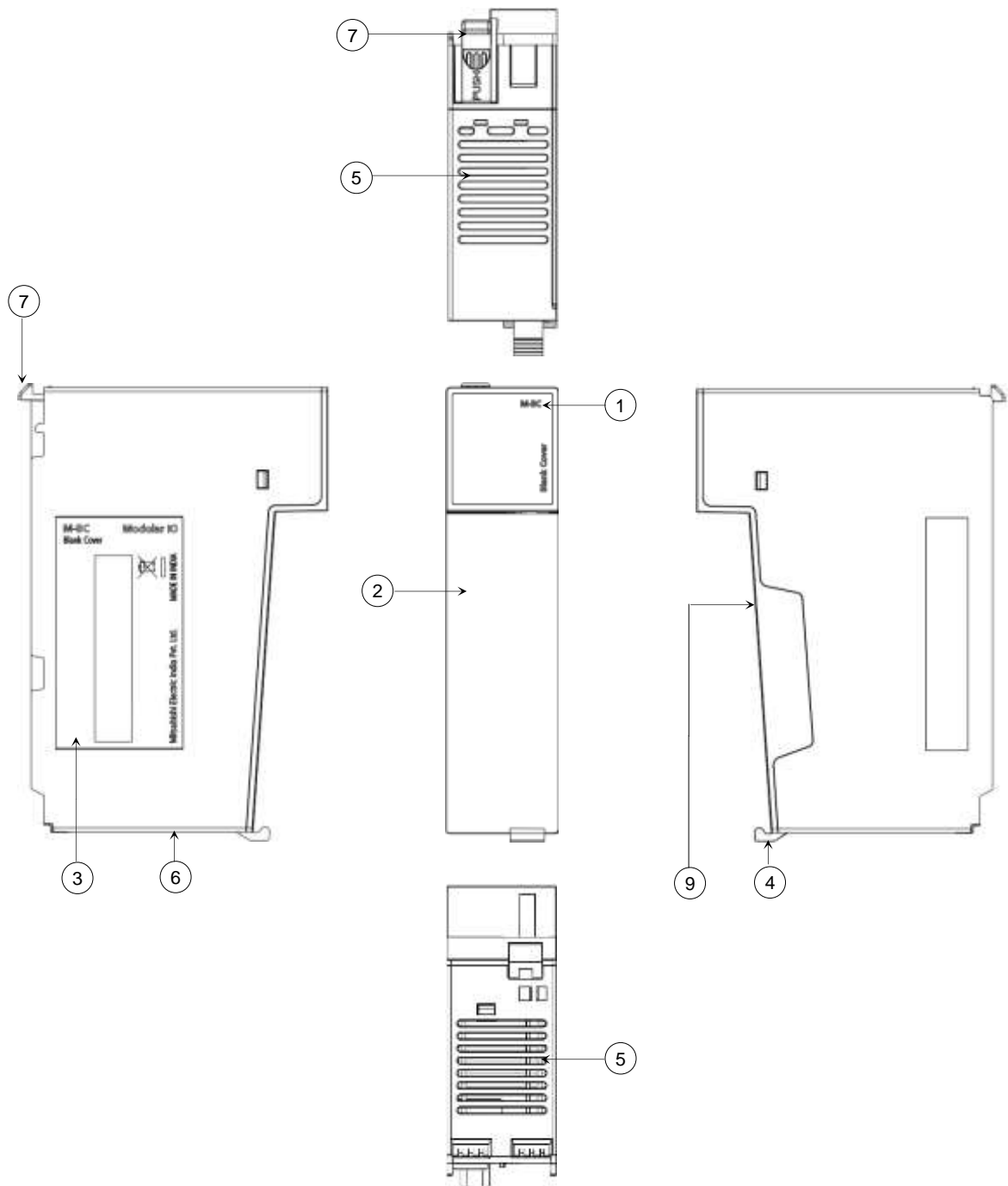

















Blank Cover Module: M-BC



No.	Description	No.	Description
1	Module ordering code	5	Air vents at top and bottom side
2	Blank plastic cover	6	Guide at top and bottom side for IO module attachment in next slot
3	Wiring label	7	Module latch
4	Hinge support for terminal block		

Ordering Information

This section provides list of available modules along with ordering information and current consumption details.

Ordering Information	Ordering Code	Colour Identification ^[*1]	Current Consumption (in mA) ^[*2]
Header			
CC Link IE Field Basic Header Module	M-CCB-H		+2000
Modbus TCP Header Module	M-MT-H		+2000
Ethernet/ IP Header Module	M-EIP-H		+2000
CC Link IE Field Header Module ^[*4]	M-CCIEF-H		-2000
Digital Input			
4 Digital Input, 24 VDC, Sink Type Module (Negative Common)	M-4D		-40
8 Digital Input, 24 VDC, Sink Type Module (Negative Common)	M-8D		-45
16 Digital Input, 24 VDC, Sink Type Module (Negative Common)	M-16D		-65
4 Digital Input, 24 VDC, Source Type Module (Positive Common)	M-4DE		-40
8 Digital Input, 24 VDC, Source Type Module (Positive Common)	M-8DE		-45
16 Digital Input, 24 VDC, Source Type Module (Positive Common)	M-16DE		-65
Digital Output			
4 Digital Output, 24 VDC, Source Type Module	M-4TE		-90
8 Digital Output, 24 VDC, Source Type Module	M-8TE		-105
16 Digital Output, 24 VDC, Source Type Module	M-16TE		-130
Analog Input			
2 Channel Universal Analog Input Module	M-UAD2		-100
4 Channel Analog Voltage/ Current Input Module	M-AD4		-100
8 Channel Analog Voltage Input Module	M-ADV8		-100
8 Channel Analog Current Input Module	M-ADI8		-100
4 Channel Thermocouple/ RTD Input Module	M-TCRT4		-100
Analog Output			
2 Channel Analog Voltage/ Current Output Module	M-DA2		-95
4 Channel Analog Voltage/ Current Output Module	M-DA4		-105
Special Functions			
2 Channel Serial COM (RS232) Module	M-2R2		-50
1 Channel Serial COM (RS232) Module	M-1R2		-50
1 Ch. Serial (RS422/ RS485) Communication Module	M-1R4		-50

System Functions			
System Power Extension Module	M-SPE		+2000
Field Power Distribution Module	M-FPD		--
Field Power Isolator Module	M-FPI		--
Shield Termination Module	M-ST		--
Bus End Module	M-BE	--	--
2-Slots Base Module	M-B2	--	--
3-slots Base Module	M-B3	--	--
5-slots Base Module	M-B5	--	--
Redundant AC Power Supply Module	M-APSU		+2000
24 VDC Power Supply Module	M-DPSU		+2000
I/O Adapter Module	M-ADP		--
Blank Cover Module	M-BC	--	--

*1 Color code is provided on LED label and at bottom side of terminal block. Users should always ensure that the color code of LED label and terminal block is identical.

*2 Modules with positive value are the source of system power for I/O modules. Modules with negative value indicate consumption of system power.

*3 Digital and analog IO modules are intelligent modules and provide IO data and diagnostics to Header module. System modules are passive modules. So, Header module does not provide any information about system modules except Header assembly modules M-APSU and M-ADP.

*4 The header module "M-CCIEF-H" supports "CC-Link IE Field" and "CC-Link IE TSN" protocols. Protocol is user configurable. User can choose the protocol using the "Bus type" setting while creating project in the Modular IO Configurator tool. Support for CC-Link IE TSN protocol is available for Header Version 1.1.0.0 and Modular IO Configurator tool Version 2.1.0.0; Earlier versions (Header Version 1.0.0.0 and Modular IO Configurator tool Version 2.0.0.0) of the header module and the Modular IO Configurator support only "CC-Link IE Field."

NOTE

- Modules are available with and without conformal coating. If module ordering code has suffix as '-C', module is with conformal coating. For example, module M-CCB-H-C, M-UAD2-C are with conformal coating.
- The specifications for modules with conformal coating are the same as those without conformal coating. For instance, the specifications for M-CCB-H and M-CCB-H-C are identical
- In Modular IO Configurator Tool, module with and without conformal coating is identical. For example, to configure module M-CCB-H and M-CCB-H-C, configure module M-CCB-H.

Environmental Specifications

This section provides environmental specifications of modular IO station.

Specification	Description	
Operating temperature	Operating: 5 to 55 °C	Storage: -40 to 70 °C
Humidity	Operating: 10 to 95 % RH, No condensation	Storage: 10 to 95 % RH, No condensation
Altitude	2000 m or less	
Pollution level	2 maximum. (only non-conductive pollution)	
Operating atmosphere	Corrosive gas must not be present	
IP protection	IP20	

Approvals: EU Directives and Standards

EMC Directives

Item	Description
Approvals	CE
EMC – Directives 2014/30/EU	EN 61131-2 Programmable logic controllers Part 2: Guidance for inspection and routine testing
	EN IEC 61000-6-2 Electromagnetic compatibility (EMC) Part 6-2: Generic standards - Immunity standard for industrial environments
	EN IEC 61000-6-4 Electromagnetic compatibility (EMC) Part 6-4: Generic standards - Emissions standard for industrial environments

Requirements for Immunity to Disturbances

Immunity	Testing performed per standard:	Requirements per standard:	
		EN 61131-2 ¹⁾	EN IEC 61000-6-2 ²⁾
Electrostatic discharge (ESD)	EN 61000-4-2	✓	✓
Radiated RF Electromagnetic Field Immunity	EN IEC 61000-4-3	✓	✓
Electric Fast transient/ Burst Immunity	EN 61000-4-4	✓	✓
Surge voltages (Surge)	EN 61000-4-5	✓	✓
Conducted Radio Frequency Immunity	EN 61000-4-6	✓	✓
Power Frequency Magnetic Fields Immunity	EN 61000-4-8	✓	✓
Voltage (Short) Interruptions	EN 61000-4-29*	✓	--
Voltage Dips	EN 61000-4-29*	--	--
Voltage (Short) Interruptions	EN 61000-4-11**	✓	--
Voltage Dips	EN 61000-4-11**	✓	--

1) EN 61131-2: Product standard - Programmable logic controllers

2) EN IEC 61000-6-2: Generic standard - Immunity for industrial environments

* Applicable for 24VDC Power supply module (M-DPSU)

** Applicable for AC Power supply module (M-APSU)

Criteria to prove the performance of a PLC system against EMC disturbances

Criteria	During test	After test
A	The PLC system shall continue to operate as intended. No loss of function or performance.	The PLC system shall continue to operate as intended.
B	Degradation of performance accepted. The operating mode is not permitted to change. Irreversible loss of stored data is not permitted.	The PLC system shall continue to operate as intended. Temporary degradation of performance must be self-recoverable.
C	Loss of functions accepted, but no destruction of hardware or software (program or data)	The PLC system shall continue to operate as intended automatically, after manual restart or power off / power on.
D	Degradation or failure of functionality that can no longer be restored	PLC system permanently damaged or destroyed.

Electrostatic discharge (ESD)

Testing performed per standard: EN 61000-4-2	Requirements per standard: EN 61131-2 / Zone B	Requirements per standard: EN IEC 61000-6-2
Contact discharge (CD) to conductive accessible parts		±4 kV Criteria B
Air discharge (AD) to insulating external parts		±8 kV Criteria B

Radiated RF Electromagnetic Field Immunity

Testing performed per standard: EN IEC 61000-4-3	Requirements per standard: EN 61131-2 / Zone B	Requirements per standard: EN IEC 61000-6-2
Enclosure with wiring		80 MHz to 1000 MHz, 10 V/m 1400 MHz to 2000 MHz, 3 V/m 2000 MHz to 2700 MHz, 3 V/m 2700 MHz to 6000 MHz, 3 V/m Criteria A

Electrical Fast Transient/ Burst (EFT/B) Immunity

Testing performed per standard: EN 61000-4-4	Requirements per standard: EN 61131-2 / Zone B	Requirements per standard: EN IEC 61000-6-2
Mains 24VDC, Mians 230VAC		±2 kV / 5 kHz Criteria B
Ethernet port, Serial port, Digital IOs, Analog IOs		±1 kV / 5 kHz Criteria A

Surge Immunity

Testing performed per standard: EN 61000-4-5	Requirements per standard: EN 61131-2 / Zone B	Requirements per standard: EN IEC 61000-6-2
Mains 24VDC, Mians 230VAC		Differential Mode: ±0.5 kV Common Mode: ±1 kV Criteria B
Shielded line of Ethernet port		±1 kV Criteria B

Conducted Radio Frequency Immunity

Testing performed per standard: EN 61000-4-6	Requirements per standard: EN 61131-2 / Zone B	Requirements per standard: EN IEC 61000-6-2
Mains 24VDC, Mains 230VAC		10 Vrms 150 kHz to 80 MHz 80% AM (1 kHz) Criteria A
Ethernet port, Serial port, Digital IOs, Analog IOs		10 Vrms ¹⁾ 150 kHz to 80 MHz 80% AM (1 kHz) Criteria A

1) Only for connections with a permitted line length greater than 3 m.

Power Frequency Magnetic Fields Immunity

Testing performed per standard: EN 61000-4-8	Requirements per standard: EN 61131-2 / Zone B	Requirements per standard: EN IEC 61000-6-2
Enclosure with wiring		30 A/m 3 axes (x, y, z) 50/60 Hz ¹⁾ Criteria A

1) Main frequency as per manufacturer data.

Voltage (Short) Interruptions

Testing performed per standard: EN 61000-4-29	Requirements per standard: EN 61131-2 / Zone B
Mains 24VDC, Mains 230VAC	0% residual voltage ≥10 ms Criteria A

Voltage Dips

Testing performed per standard: EN IEC 61000-4-11	
230VAC	0% residual voltage (1/2 Cycle) Criteria A
	40% residual voltage (10 Cycles) Criteria C
	70% residual voltage (250 Cycles) Criteria C

Emission Requirements

Phenomenon	Testing performed per standard:	Requirements per standard:	
		EN 61131-2 ¹⁾	EN IEC 61000-6-4 ²⁾
Conducted emission (Emissions related to lines)	CISPR 11:2015+A2:2019 Clause 7.3 of CISPR 16-2-3	✓	✓
Radiated emissions	CISPR 11:2015+A2:2019 Clause 7.3 of CISPR 16-2-3	✓	✓

1) EN 61131-2: Product standard - Programmable logic controllers

2) EN IEC 61000-6-4: Generic standards - Emission standard for industrial environments

Conducted Emission

Testing performed per standard: EN IEC 61000-6-4	Limit values per standard: EN 61131-2 / Zone B
Mains 24VDC, Mains 230VAC	150 kHz to 5 MHz 89 to 83 dB (μV) quasi-peak value 76 to 70 dB (μV) average value
	5 MHz to 30 MHz 83 dB (μV) quasi-peak value 70 dB (μV) average value

Testing performed per standard: CISPR 11:2015+A2:2019	Limit values per standard: EN 61131-2 / Zone B	Limit values per standard: EN IEC 61000-6-4
Ethernet port	150 kHz to 500 kHz 97 to 87 dB (μV) quasi-peak value 84 to 74 dB (μV) average value	
	500 kHz to 30 MHz 87 dB (μV) quasi-peak value 74 dB (μV) average value	

Radiated emissions

Testing performed per standard: CISPR 11:2015+A2:2019	Limit values per standard: IEC 61131-2 / Zone B	Limit values per standard: EN IEC 61000-6-4
Electric field / Measured from 3 m 30 MHz to 1 GHz	30 to 230 MHz 50 dB (μV/m) quasi-peak value	
	230 MHz to 1 GHz 57 dB (μV/m) quasi-peak value	

Mechanical Conditions

Vibration test

Testing performed per standard: IEC 60068-2-6	Limit values per standard: EN 61131-2	
Vibration test	Frequency	Amplitude
	5 to 8.4 Hz ¹⁾	Constant displacement: 3.5 mm _{peak} ¹⁾
	8.4 to 150 Hz ¹⁾	Constant acceleration 10 m/s ² _{peak} ¹⁾

1) In all 3 axes (x, y, z); Sweeping rate of 1 octave per minute with ±10%.

Shock test

Testing performed per standard: IEC 60068-2-27	Requirements per standard: EN 61131-2
Shock test	Acceleration 150 m/s ² peak ¹⁾ Duration 11 ms, 18 shocks

1) Pulse (half-sine) stress in all 3 axes (x, y, z).

Free fall withstand test

Testing performed per standard: IEC 60068-2-32	Requirements per standard: EN 61131-2 with product packaging	
Free fall withstand test	Weight	Height
	<10kg	0.3 m
	10 to 40 kg	0.3 m
	>40 kg	0.25 m
5 attempts		

Electrical Safety

Over voltage category

Requirement per standard: EN 61131-2	
Overvoltage category	OVC II

Pollution degree

Requirement per standard: EN 61131-2	
Pollution degree	PD2 (only non-conductive pollution)

Overview of Standards

Standard	Description
EN 55011 (CISPR 11)	Industrial, scientific, and medical equipment - Radio frequency disturbance characteristics - Limits and methods of measurement
IEC 60068-2-6	Environmental testing Part 2-6: Tests - Test Fc: Vibration (sinusoidal)
IEC 60068-2-27	Environmental testing Part 2-27: Tests - Test Ea and guidance: Shock
IEC 60068-2-31	Environmental testing Part 2-31: Tests - Procedure 1: Free fall
EN 61000-4-2	Electromagnetic compatibility (EMC) Part 4-2: Testing and measurement techniques - Electrostatic discharge immunity test
EN IEC 61000-4-3	Electromagnetic compatibility (EMC) Part 4-3: Testing and measurement techniques - Radiated, radio frequency, electromagnetic field immunity test
EN 61000-4-4	Electromagnetic compatibility (EMC) Part 4-4: Testing and measurement techniques - Electrical fast transient/burst immunity test
EN 61000-4-5	Electromagnetic compatibility (EMC) Part 4-5: Testing and measuring techniques - Surge immunity test
EN 61000-4-6	Electromagnetic compatibility (EMC) Part 4-6: Testing and measurement techniques - Immunity to conducted disturbances, induced by radio-frequency fields
EN 61000-4-8	Electromagnetic compatibility (EMC) Part 4-8: Testing and measuring techniques - Power frequency magnetic field immunity test
EN 61000-4-29	Electromagnetic compatibility (EMC) Part 4-29: Testing and measurement techniques - Voltage dips, short interruptions, and voltage variations on DC input power port immunity tests
EN IEC 61000-6-2	Electromagnetic compatibility (EMC) Part 6-2: Generic standards - Immunity standard for industrial environments
EN IEC 61000-6-4	Electromagnetic compatibility (EMC) Part 6-4: Generic standards - Emission standard for industrial environments
EN 61131-2	Programmable logic controllers Part 2: Guidance for inspection and routine testing

[Back To Index Page](#)

2 Installation

[Dimension Details](#)

[Recommendations and Precautions](#)

[Mounting of Header Module](#)

[Mounting of IO Module](#)

[Mounting of Header Assembly](#)

[Fixing and removal of terminal block](#)

[Insertion and removal of SDHC memory card in Header card slot](#)

Dimension Details

This section provides dimensional details of terminal block, Header module and IO module.

8 Point Terminal Block:

The figure below shows dimensional details of the 8-point terminal block.

All dimensions are in mm.

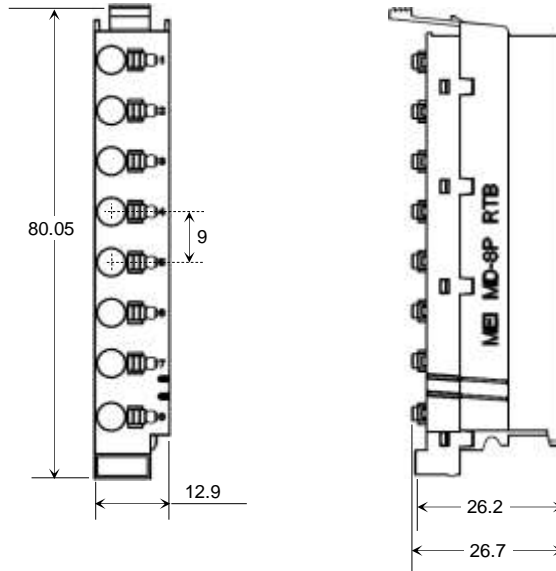

16 Point Terminal Block:

The figure below shows dimensional details of 16-point terminal block.

All dimensions are in mm.

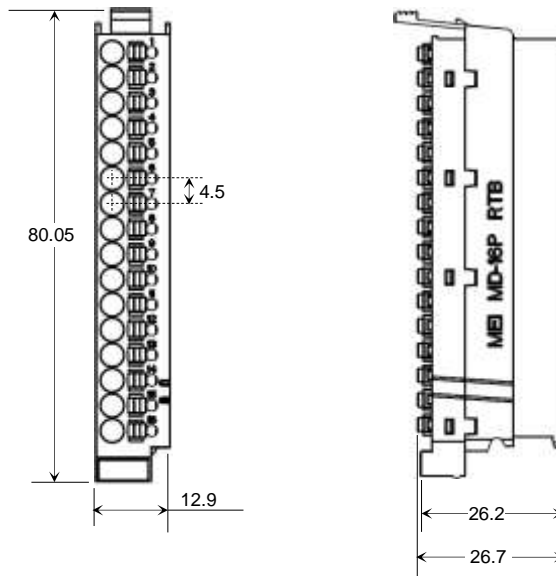

Header Module: M-CCB-H, M-MT-H, M-EIP-H

The figure below shows dimensional details of Header module.

All dimensions are in mm

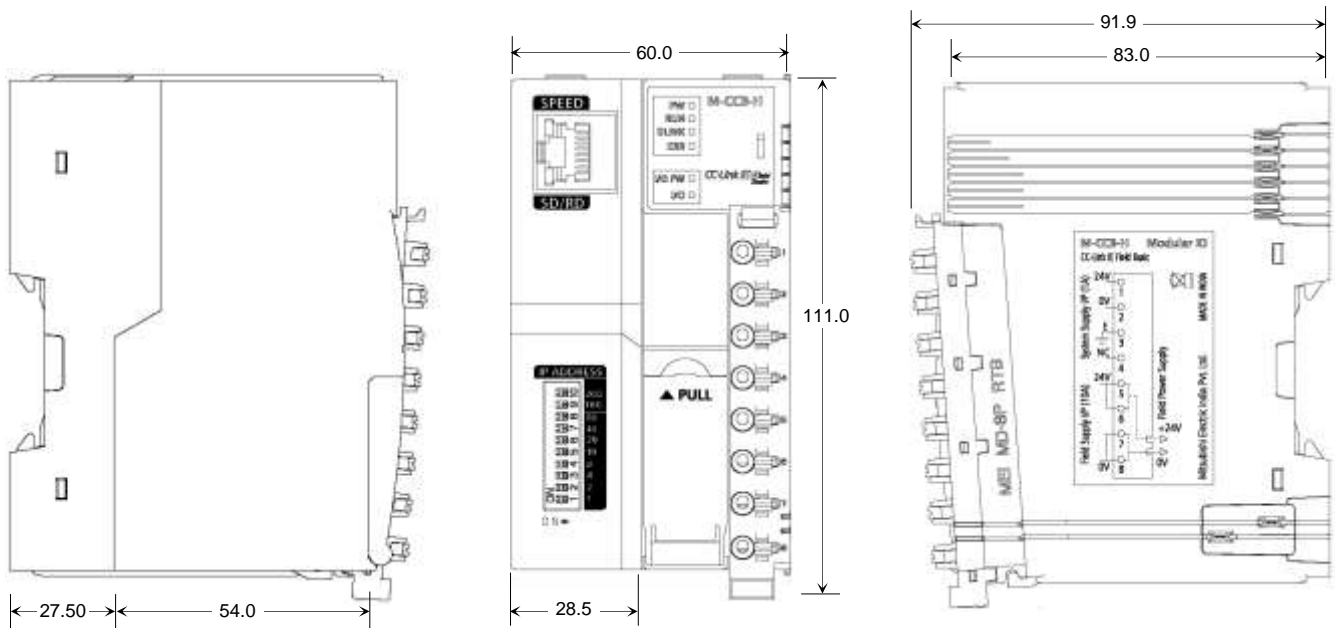

IO Module: M-16D, M-16DE, M-16TE, M-AD4, M-ADi8, M-ADV8, M-TCRT4, M-4D, M-DE, M-8D, M-8DE, M-4TE, M-8TE, M-UAD2, M-DA2, M-DA4, M-1R2, M-1R4, M-2R2, M-FPD, M-FPI, M-SPE, M-ST

The figure below shows dimensional details of IO module.

All dimensions are in mm.

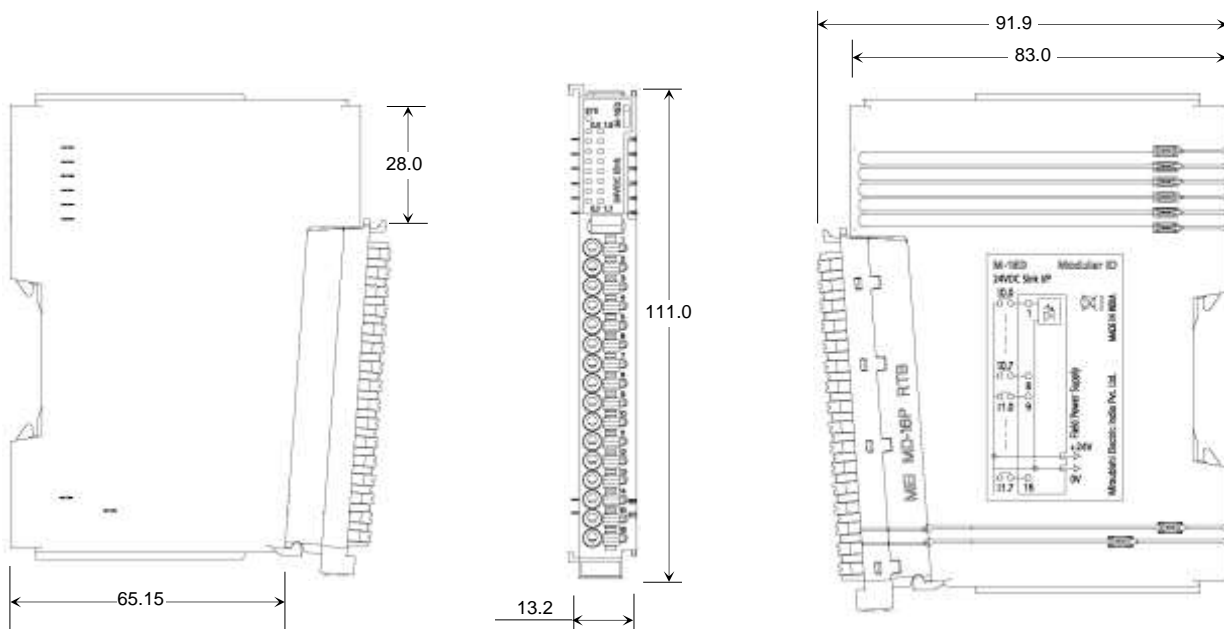

* Dimensional details of modules with 8-point terminal block and 16-point terminal block are identical.

The following section provides dimensional details for modules of redundant header assembly.

2-Slots Base Module: M-B2

The figure below shows dimensional details of the 2-slots base module.

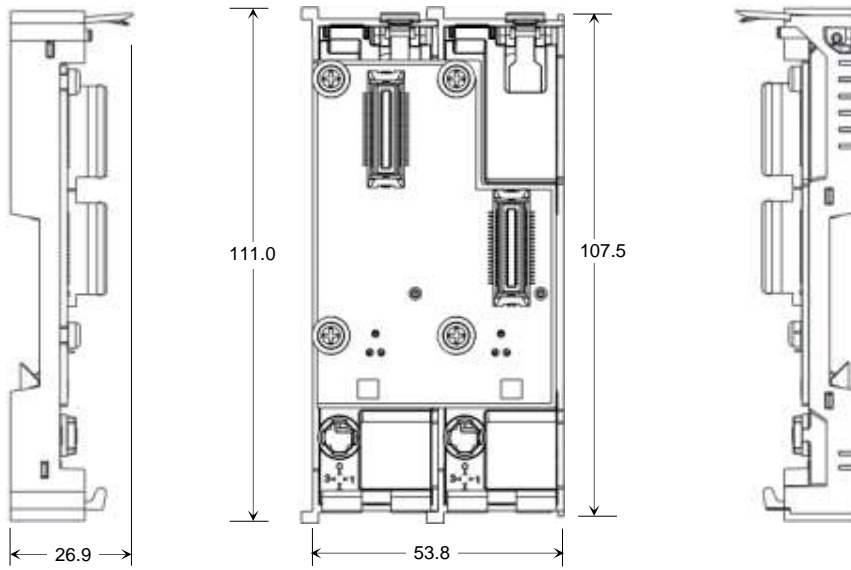

3-Slots Base Module: M-B3

The figure below shows dimensional details of the 3-slots base module.

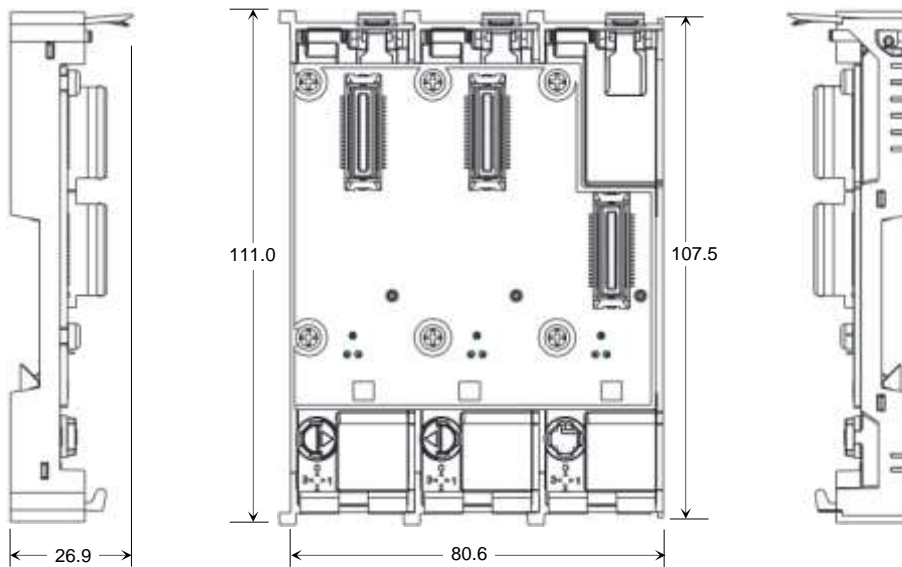

5-Slots Base Module: M-B5

The figure below shows dimensional details of 5-slots base module.

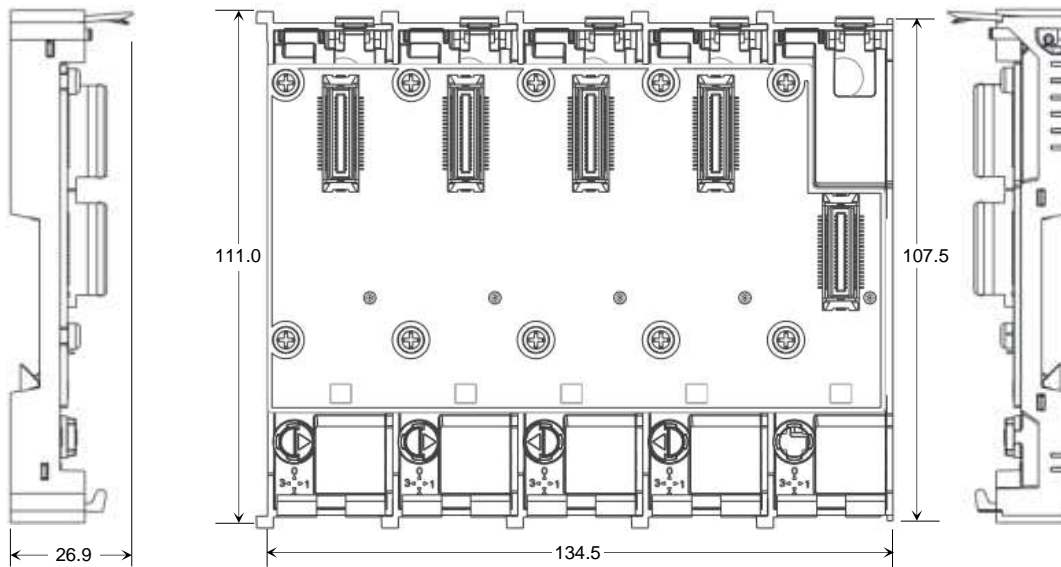

Redundant AC Power Supply Module: M-APSU

Blank cover: M-BC

The figure below shows dimensional details of redundant ac power supply module.

All dimensions are in mm.

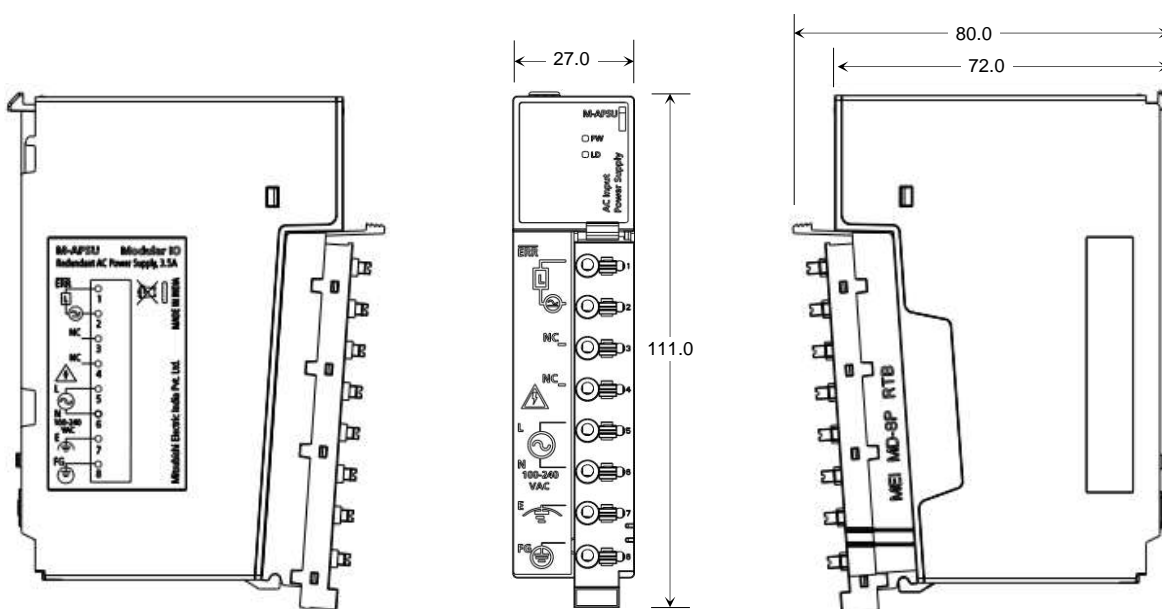

24 VDC Input Power Supply Module: M-DPSU

The figure below shows dimensional details of DC input power supply module.

All dimensions are in mm

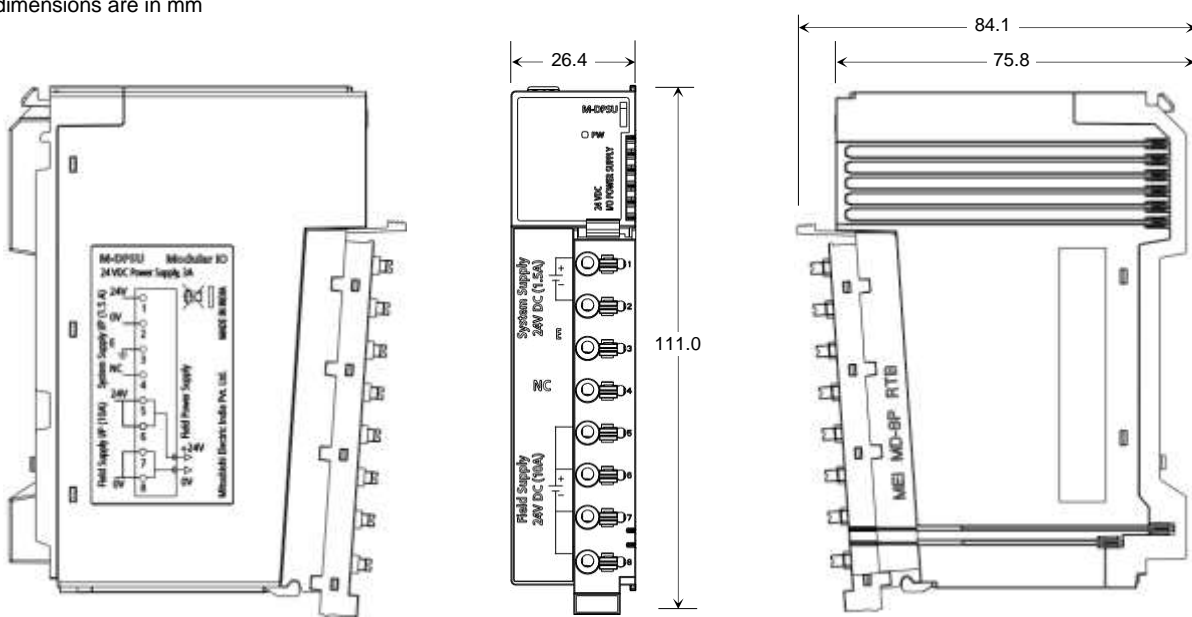

Header Module: M-CCIEF-H

The figure below shows dimensional details of redundant Header module.

All dimensions are in mm

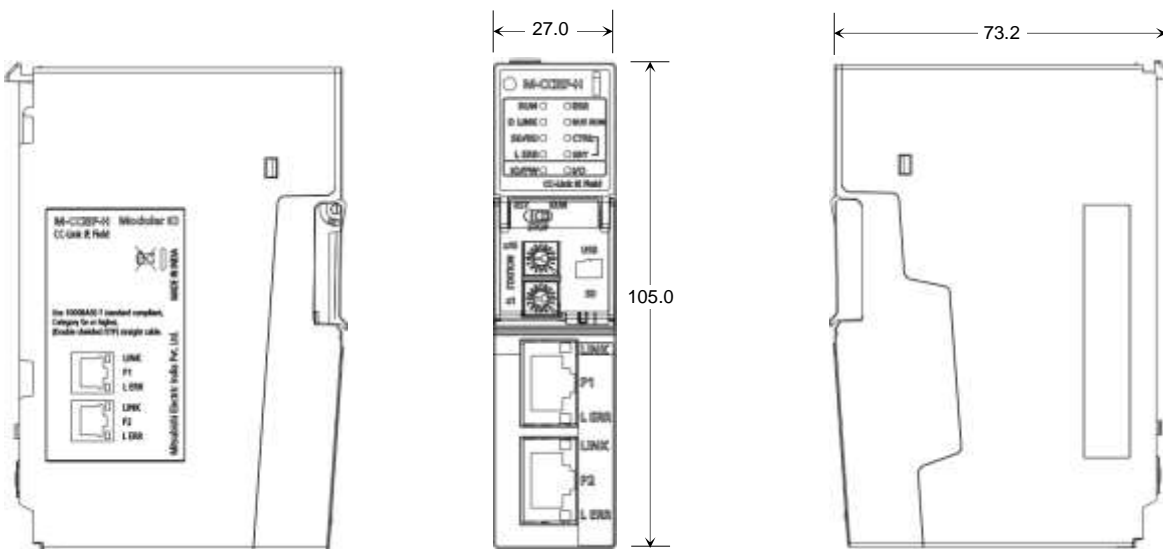

IO Adapter Module: M-ADP

The figure below shows dimensional details of IO adapter module.

All dimensions are in mm.

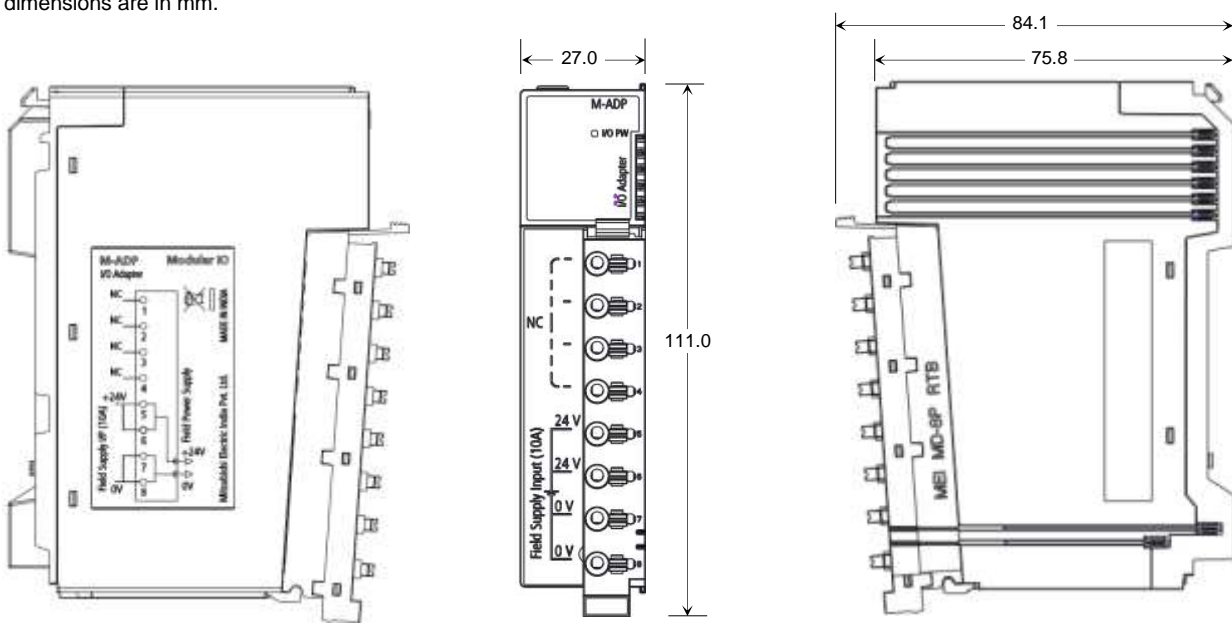

Recommendations and Precautions

This section provides list of instructions, recommendations and precautions to be observed during installation of modular IO station.

! Instructions:

1. During installation, ensure that the power supply to the station and to the control panel is cut off.
2. Install modular IO station, horizontally only on firm, plane and conducting surface to facilitate heat transfer through module by natural convection.

To maintain the cooling, it is important to install the modular IO station with recommended orientation such that the natural flow of hot air will not be obstructed. Installation in orientation other than recommended one, may cause overheating and subsequently malfunctioning of the station.

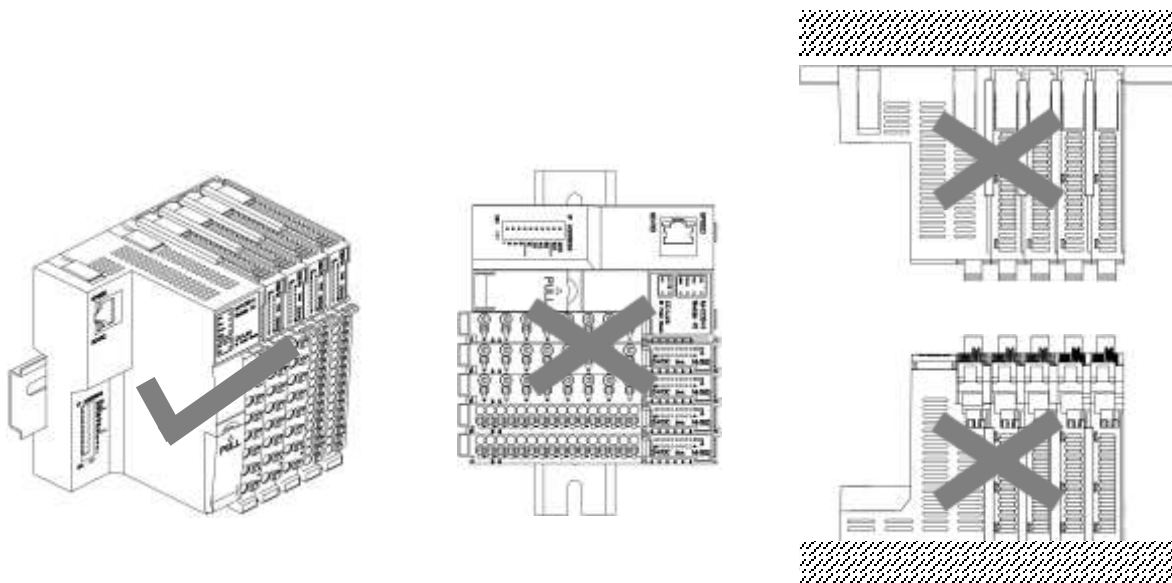

3. Install Header module at the leftmost side and IO modules on its right side.
4. Do not touch pins and receptacles (which are conductive parts) interface of System power supply and Field power supply, to protect them against ESD (Electrostatic Discharge) which may cause damage to electronic hardware.

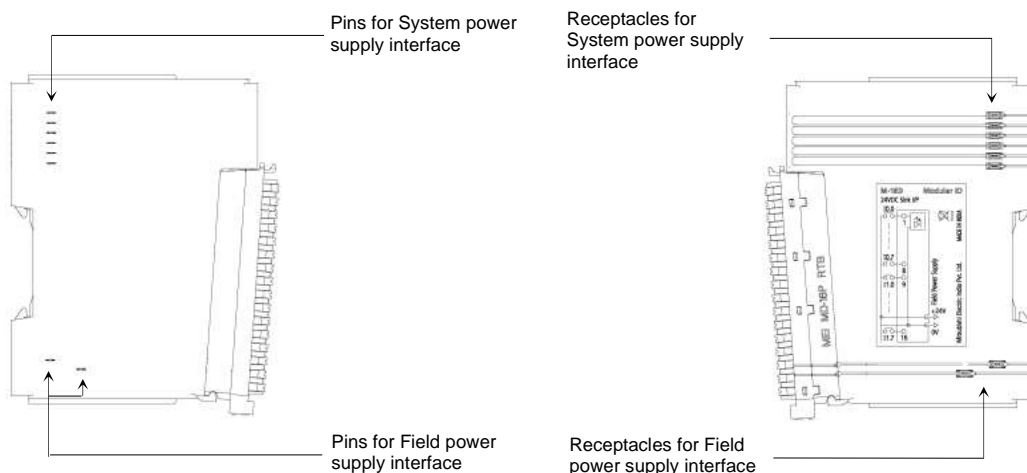

! Recommendations:

1. For modular IO station installation, standard DIN rail of type TS 35 mm/ 7.5 mm with thickness of 1 mm is recommended.



2. Before mounting DIN rail, inside the control panel,
 - Ensure that the thickness of cabinet wall is 2 mm and more.
 - Ensure that DIN rail orientation is horizontal.
 - Inside panel, the minimum depth of the cabinet should be 200 mm to facilitate easy insertion and removal of the modules, easy insertion and removal of terminal block and wiring of IO modules.
 - Inside the control panel, minimum space around modular IO station should be as shown below, to facilitate air circulation.

All dimensions are in mm

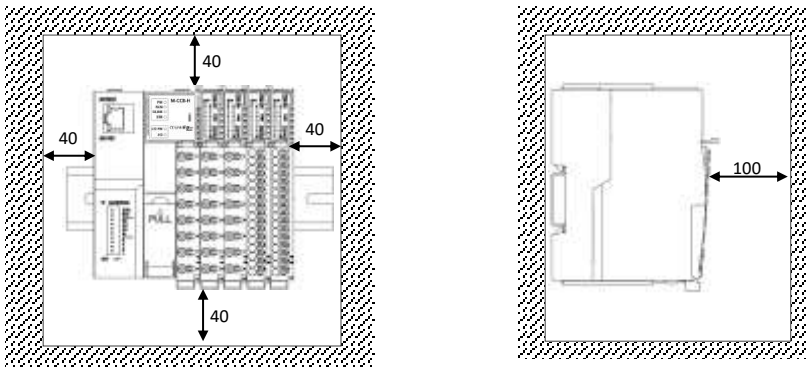

3. Humid environment for long time can reduce component life. So, it is recommended to fix absorbent material inside panel and do not expose modular IO station to humid atmosphere for an extended period.

⚠ Precautions:

1. Maintain proper thermal distances between Modular IO station and other equipment which produces heat inside control panel.
2. Dust can cause a problem when it accumulates on the electronic components. Sometimes, electrically conductive dust may cause short circuit or other failure.
Proper dust tight control panels, filters, rubber gaskets, etc. should be provided to minimize this problem.
3. The ambient temperature of the installation location should be between 0 to 60°C. Cooling of the electrical and electronic components is accomplished by method of convection.
4. Due to excessive or continuous vibrations or shocks, PCB components, sockets, on-board soldered components etc. may disengage from their counter positions. It is recommended to mount modular IO station on solid, non-vibrating surfaces and should be protected by rubber so that the shock is not felt.
5. During transit or due to excessive and continuous vibrations or shocks, modular IO station may slide horizontally on DIN rail and may dislocate from its position. In such case, it is recommended to fix end clamps at both sides of modular IO station.

Refer section [Mounting of Header Module](#) and [Mounting of IO Module](#) for more details of installation.

Mounting of Header Module

This section explains how to mount Header module on DIN rail.

1. For modular IO station installation, use standard DIN rail of type TS 35 mm/ 7.5 mm (± 1 mm) with thickness of 1 mm (± 0.1 mm).

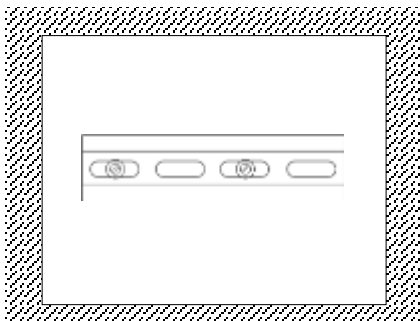

NOTE

DIN rail not complying to the specified standard will either cause loose fitment of module or not allow module fitment on it.

2. Before mounting Header module on DIN rail, ensure that both DIN clamp levers are fully opened.

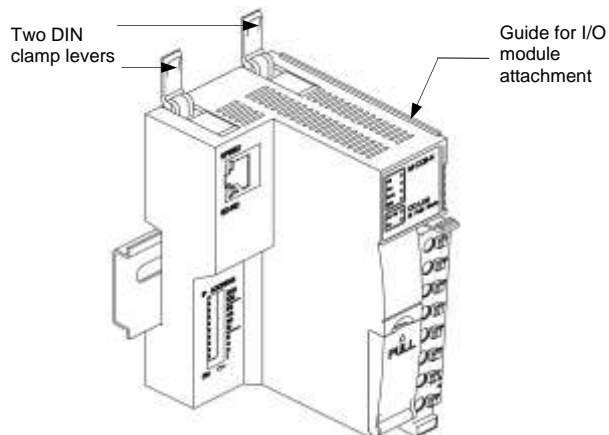

3. Hold Header module in straight orientation (between thumb and fingers) and push towards DIN rail as shown.

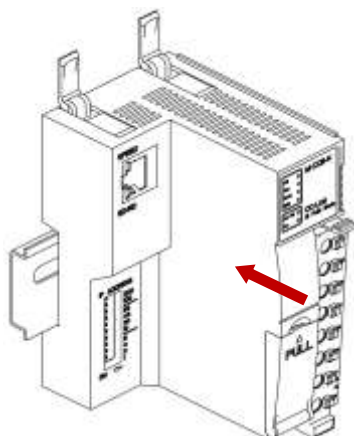

4. When DIN clamp lever is opened, DIN clamp holders reside inside. Align horizontal slot on the back side of module on DIN rail and rest on it.

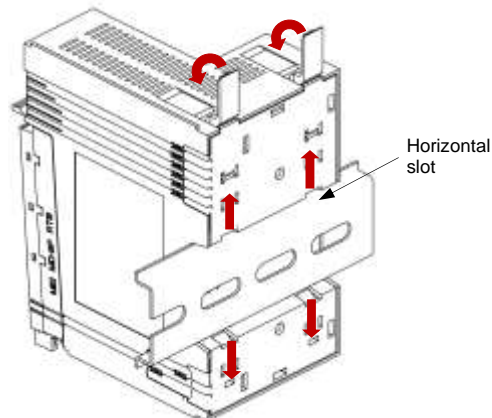

5. After resting Header module on DIN rail, close DIN clamp levers. When DIN clamp levers are closed, DIN clamp holders come outside to clamp module on DIN rail on its top edge and bottom edge as shown below.

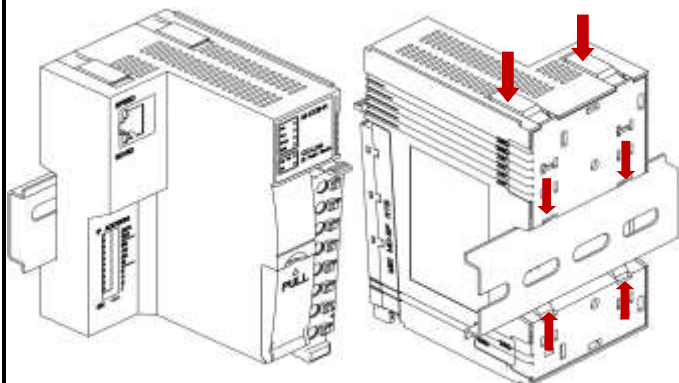

6. For **REMOVAL** of Header module, first hold it between thumb and finger. Open both DIN clamp levers provided on top side of the module. Then, gently pull the module outside.

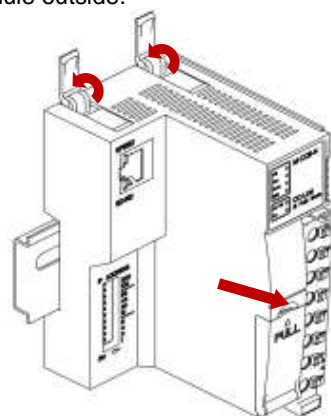

Mounting of IO Module

This section explains how to attach IO module to other modules (Header module or other IO modules) and mount on DIN rail.

1. Open DIN clamp lever located at top side of the module.
Hold IO module in straight orientation between thumb and finger.
Engage top and bottom guide of Header module (or other IO module) into the top and bottom C slots of IO module to be inserted.

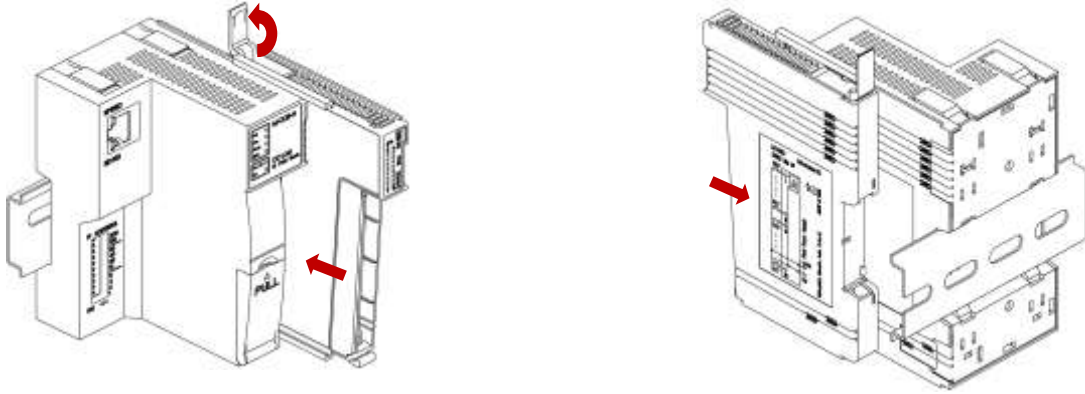

2. Once engaged, slide-in IO module gently till it rests on the DIN rail.

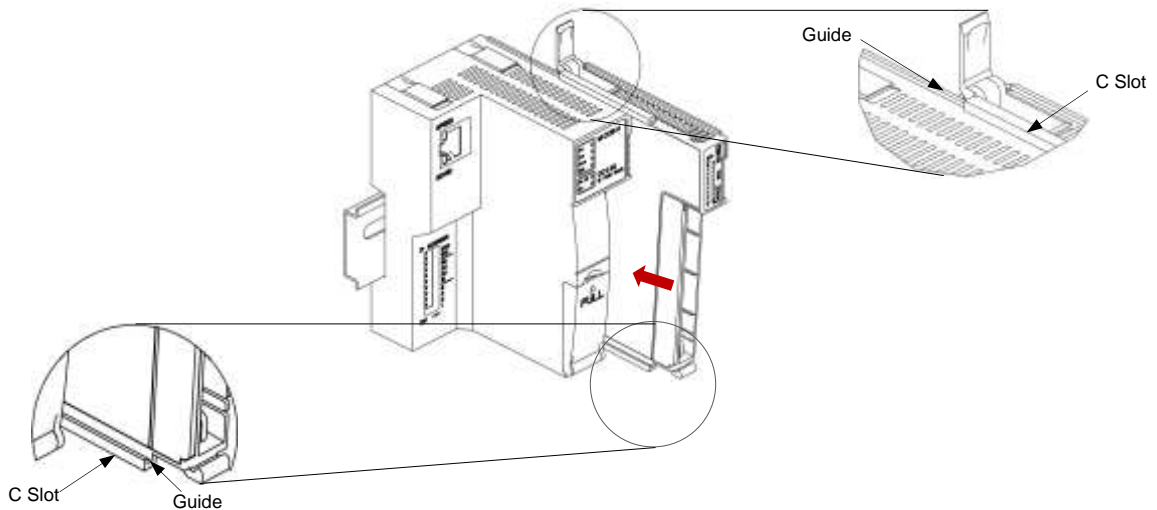

3. Lock IO module on DIN rail by closing DIN clamp lever provided on top of the module.

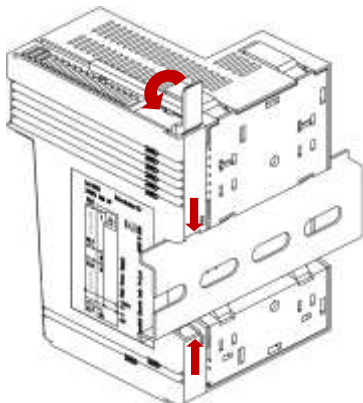

4. Figure below shows back side of IO module attached to Header module on DIN rail.

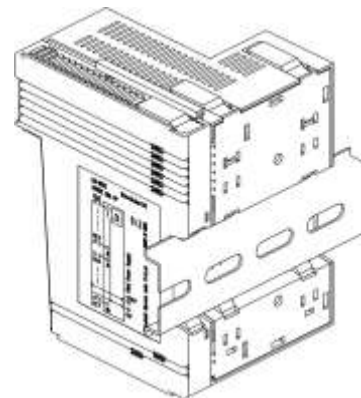

5. Figure below shows IO module attached to Header module on DIN rail and terminal block fixed on it.

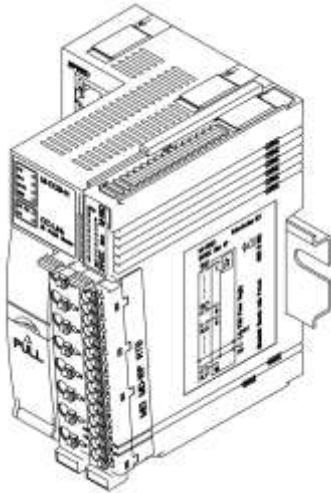

Fixing and removal of terminal block is explained in subsequent section.

6. For **Removal** of IO module, first remove terminal block fixed on IO module. Then, open DIN clamp lever located at top side. Then, hold front side of IO module between thumb and finger and pull IO module outside gently as shown.

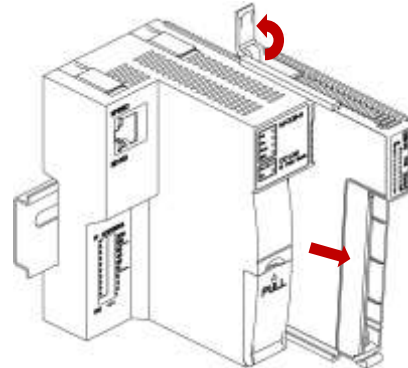

NOTE

When IO modules are attached to a Header module or other IO module on a DIN rail, backplane interface (along with system power supply and field power supply) is formed by pins and receptacles interface between the modules.

It is possible that IO module is rested on DIN rail but top or bottom C slot is not engaged with the guide of other module on left side. This may cause malfunctioning due to the loose interface of System power supply or Field power supply. In such case, a gap between the modules is visible from the front side. So, it is necessary to ensure proper engagement of IO module on top as well as bottom side before slide-in towards DIN rail. This ensures firm interface between modules.

User should attach Bus End module (M-BE) at the last slot position if there are 16 or more IO modules.

Hot swapping is not supported because removal of any intermediate module discontinues backplane interface along with system power supply and field power supply for the modules on its right side.



User should follow similar recommendations and precautions guidelines for Modular IO station as well as for Header assembly.

Mounting of Header Assembly

This section explains how to mount and remove Header assembly on DIN rail.

1. For Header assembly installation, use standard DIN rail of type TS 35 mm/ 7.5 mm (± 1 mm) with thickness of 1 mm (± 0.1 mm). Fix DIN rail on panel wall.

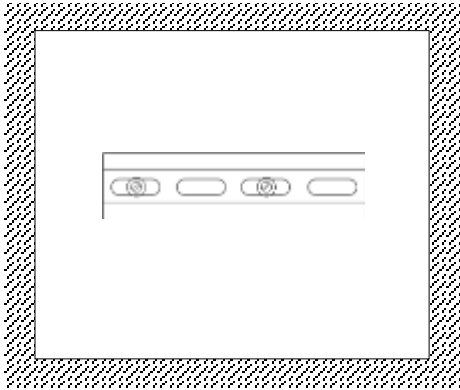

NOTE

DIN rail not complying to the specified standard will either cause loose fitment of module or not allow module fitment on it.

2. Ensure that all the DIN clamp levers on the base module are open, so the top DIN clamp holder parts are retracted into the housing. Position the base module so that the bottom DIN clamp holders engage over the bottom edge of the DIN rail, securing it with a spring action.

Once the base module is positioned on the DIN rail, close the DIN clamp levers. When the DIN clamp levers are closed, the top DIN clamp holders protrude outside to secure the base module to the top edge of the DIN rail, ensuring a firm mounting of the base module on the DIN rail.

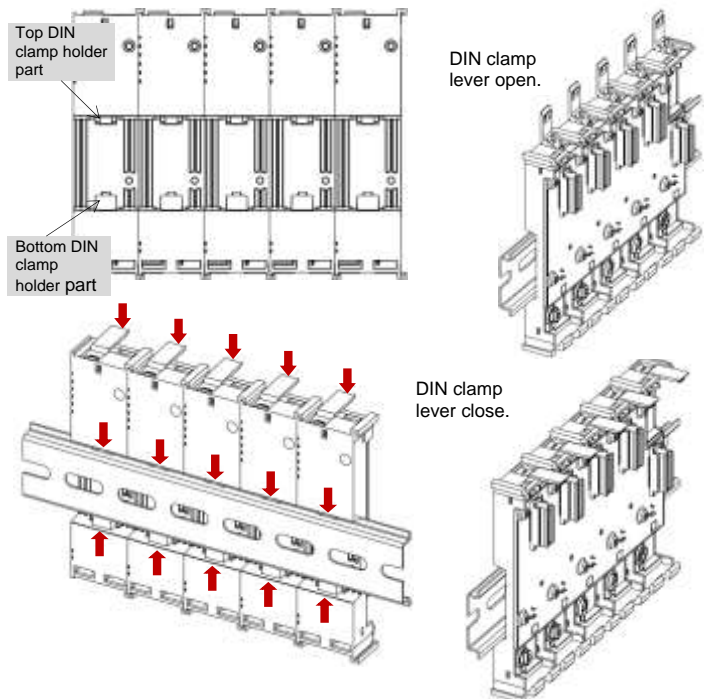

3. Mount header assembly modules in their respective slots. Example below shows mounting of 'M-APSU' module in PSU slot. While mounting, hold the module in slanted position and align module bottom with 'position guide' on base module as shown below.

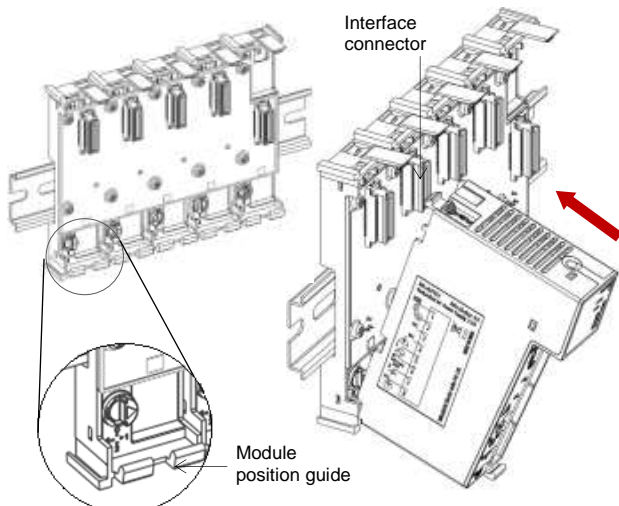

4. Push the upper part of the module so that the interface connector smoothly engages with its counterpart on the base module. Continue pushing the module until the latch clicks, securing it to the base module.

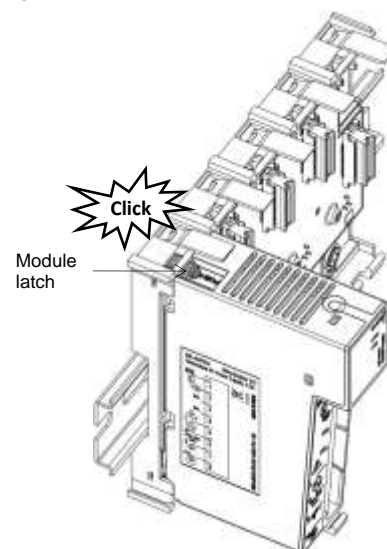



Module insertion without aligning and placing module bottom side on base module is wrong method of installation. It may damage interface connector of the module or base module.

Avoid inserting module in a way shown in the figure.

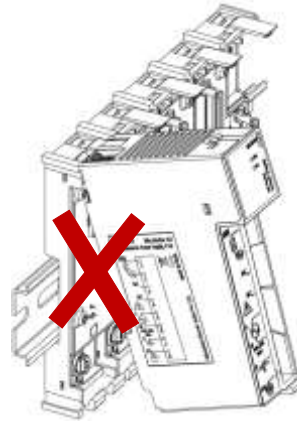

5. Mount header module and I/O adapter module in adjacent slots as shown below.

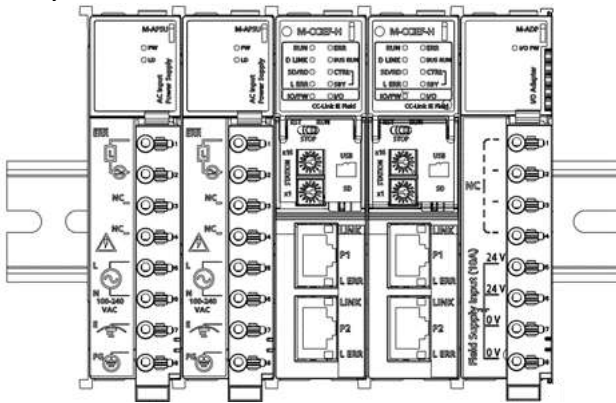

NOTE

On base modules, slots are fixed for specific module type as below

Base module	Slot number				
	1	2	3	4	5
M-B2	Header	DPSU			
M-B3	APSU	Header	ADP		
M-B5	APSU	APSU	Header	Header	ADP

Coding parts are fixed on the back side of module and base module to ensure mounting of module in desired slot.

6. After fixing I/O adapter module (M-ADP) in the right-most slot, user can attach I/O module, as shown below.

Refer procedure explained in section '[Mounting of IO Module](#)'.

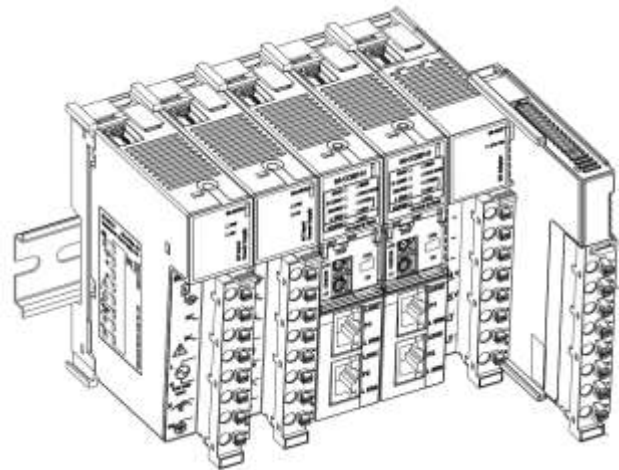

Below section explains how to remove Header assembly modules from base module.

1. Press finger impression on module latch downward to disengage module from base module.

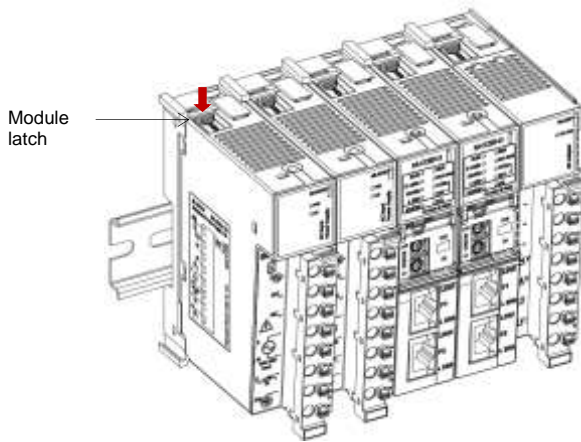

2. Pull out the module to disengage interface connectors.

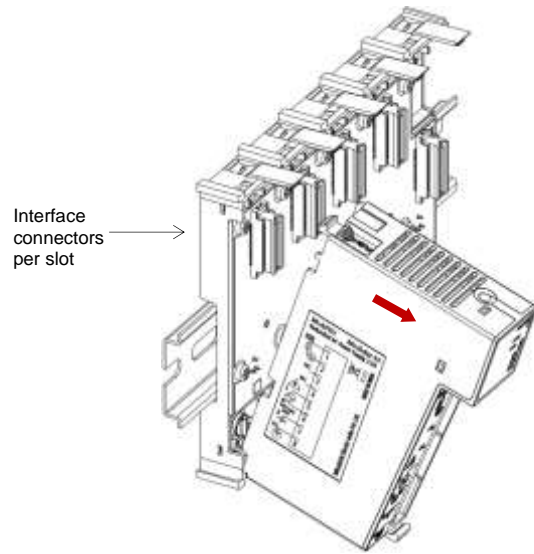

Fixing and Removal of Terminal Block

This section explains how to fix and remove terminal block on IO module.

1. Terminal block is fixed on the front of the module in slanted position. Two types of terminal blocks are available for modular IO station i.e. 8 Point and 16 point.

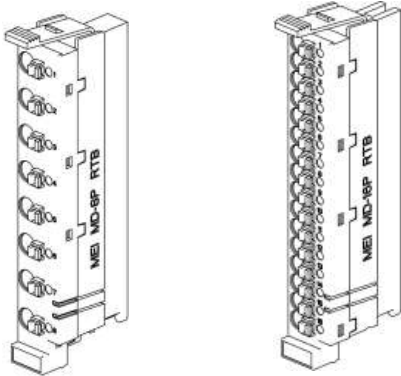

Refer section [Dimension Details](#), [Nomenclature](#) and [Ordering Information](#), for more details of terminal block.

2. The figure below shows how to fix terminal block on IO module.
Hold terminal block latch part with finger and bottom part with thumb in slanted position. Terminal block bottom side should be towards IO module. Rest bottom part of terminal block on the hinge support of the module such that round groove of terminal block is aligned over the hinge support on module as shown.

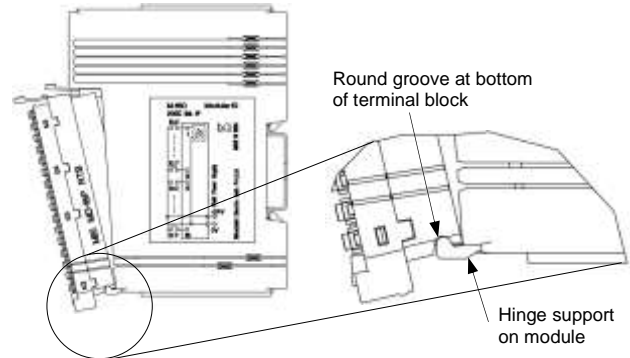

3. Once terminal block is rested on hinge support, push upper part of terminal block towards module in radial orientation till latch is clicked.
Push latch upward to ensure proper latching into the module.

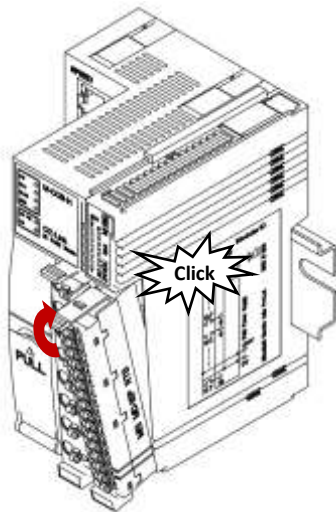

4. The figure below shows Header module and IO module with terminal blocks.

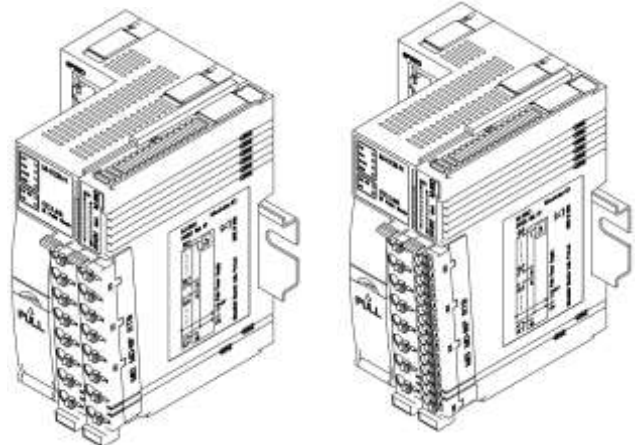

IO module fixed with **8 point** terminal block

IO module fixed with **16 point** terminal block

- 5.** For **Removal** of terminal block,
Press latch of terminal block downward so it gets disengaged from the module.
Hold latch with finger with pressed down condition and bottom of terminal block with thumb.
Pull out upper part of terminal block in radial orientation away from the module and then take out bottom part of terminal block from hinge support.

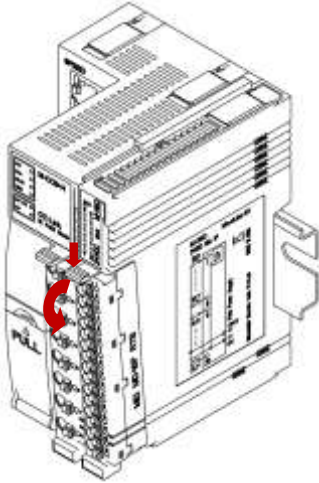

NOTE

During transit or due to excessive and continuous vibrations or shocks, modular IO station may slide horizontally on DIN rail and may dislocate from its position. In such case, it is recommended to fix end clamps at the both sides of modular IO station.

- WAGO: 249-116/117
 - ELMEX: SCKU / SCUN
 - CONNECTWELL: CA702/ 802/ 202
-



User should follow same recommendations and precautions for Modular IO station as well as for Header assembly.

Insertion and removal of SDHC memory Card in Header card slot

Header module supports use of SDHC (Secure Digital Higher Capacity) memory card to store configuration backup.

For insertion, hold SD card with orientation as shown below and gently push inside the slot till it clicks.

For removal, gently press SD card placed in the slot. It gets released and comes out. Then take out SD card from slot.

Press push button for copy configuration from Header to SD memory card.

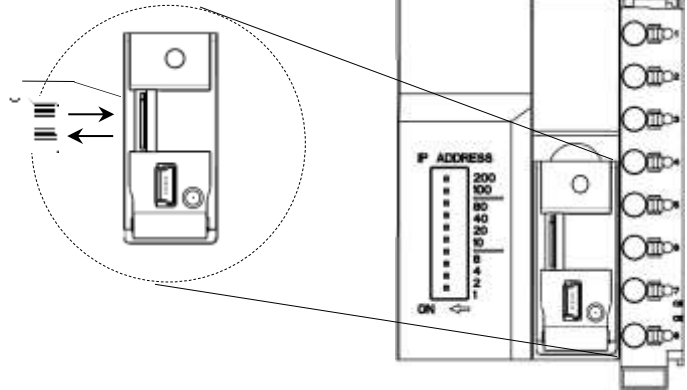

NOTE

For configuration copy between Header module and SD card, refer [5. Header Modules](#) → “[Configuration Transfer with SDHC Memory card](#)”,

For Read/ Write of configuration file, between “Modular IO Configurator” tool and SD card, refer section, [4. Modular IO Configurator](#).

[Back To Index Page](#)

3 Wiring

[Overview](#)

[Recommendations and Precautions](#)

[Wiring of Header Module and IO Module](#)

Overview

This section provides recommendations and precautions to be observed during wiring and method of wiring. Screw-less push type terminal block is fixed on the front of the module in slanted position. Refer section [Fixing and Removal of Terminal Block](#) for more details.

There are two types of terminal blocks as per module type as shown below. 8 point terminal block has pitch size of 9 mm whereas 16 point terminal block has pitch size of 4.5 mm.

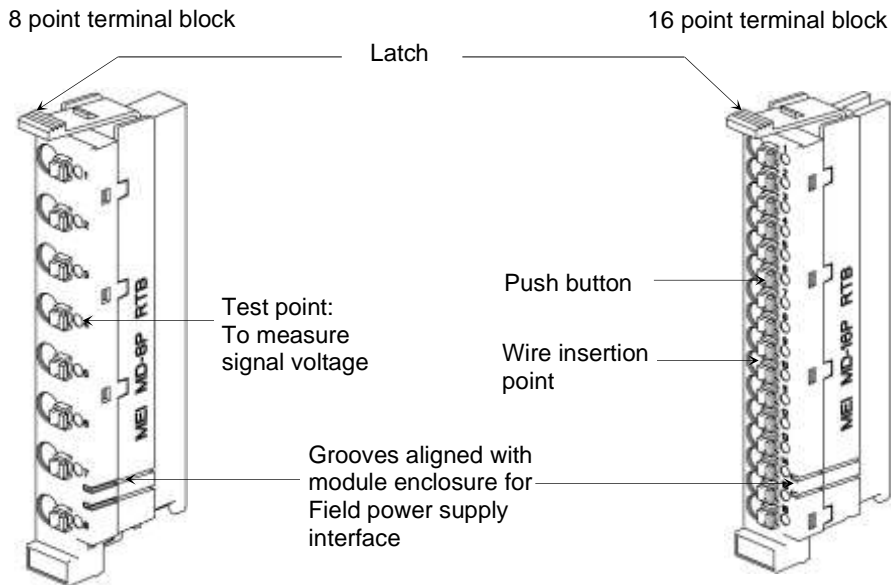

Refer sections [Dimension Details](#), [Nomenclature](#) and [Ordering Information](#) for more details of terminal block.

Recommendations and precautions

Recommendations:

1. It is recommended to use solid wire or stranded wire of 0.5 to 1.0 sq. mm (AWG 20 to 16) with 16-point terminal block and use 0.5 to 2.0 sq. mm (AWG 20 to 14) with 8 point terminal block.
2. Strip insulation of stranded wire and twist the strands to prevent it from spreading and crimp the lug with insulation.
3. Use lug with insulation. Recommended size of lug is as shown in the table below.

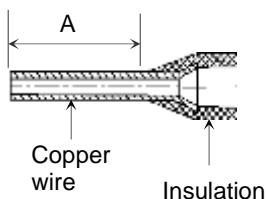

Terminal Block	Wire Size	Minimum Lug Length (A)
8-Point	0.5 mm ² to 2.0 mm ² (AWG 20 to 14)	8 mm
16-Point	0.5 mm ² to 1.0 mm ² (AWG 20 to 16)	8 mm

4. In order to maintain a similar length of all the wires connected to terminal block, it is recommended to keep difference in length in each subsequent wire, which is equal to the pitch of the terminal block.as shown below.

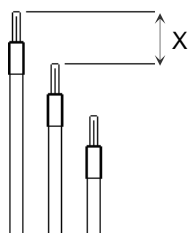

Terminal Block	Length of difference between two adjacent wires (X)
8-Pin	9 mm
16-Pin	4.5 mm

- While removing wire from terminal, use straight screw driver of smaller tip size (width 2.0 mm max., thickness of 0.4 mm max.) to press the push button.



Use of screw driver with bigger tip size may damage plastic wall above and below push button.

Precautions to be taken:

- Colour code is provided on LED label and at bottom side of terminal block. User should always ensure that colour code of LED label and terminal block is identical.
- Make sure to cut off all the phases of the power supply externally before attempting installation and wiring work. Failure to do so may cause electric shock or damage to the product.
- Ensure that length of wire that connects 24 VDC power supply to any module is less than 3 meters. Locate 24 VDC power supply near to the Modular IO station.
- It is always recommended to route cables carrying low level signals e.g. analog I/O signals, serial communication signals, Ethernet communication cables and module to module expansion cables separately and away from cables carrying high voltage and large current signals.
- It is recommended to use twisted pair cables for carrying low level signals like analog signals, communication signals.
- Connect good quality EARTH, if not, it may cause noise or erroneous operations.

Wiring of Header Module and IO Module

The table below explains procedure for wiring Header module and IO module.

Wiring	Description
	<ol style="list-style-type: none"> Ensure that module is firmly mounted on DIN rail and terminal block is fitted on it with its latch clicked with the module enclosure. Ensure that latch is pushed upward to hold terminal block with module enclosure. For wire insertion, <ul style="list-style-type: none"> Insert wire crimped by lug with insulator through wire insertion point. Apply gentle push (upto 20N) till it clicks. Wire gets firmly hold by spring clamp inside. For removal of wire, <ul style="list-style-type: none"> Use screw driver of smaller tip size (width 2.0 mm max., thickness of 0.4 mm max.) Press push button using screw driver gently so that wire lug is released Pull out wire from terminal point and release the push button. <p>NOTE</p> <p>Push button pressing force should not exceed 50 N force. It may cause damage to push button or terminal block.</p>

NOTE

Terminal block complies for the Pull-out test according to IEC/EN 60947-7-1, IEC/EN 60998-2-2, IEC/EN 60999-1

Refer section [Nomenclature](#) for more details of terminal block and refer section [Wiring: Module Supply](#) for wiring details of Header module.

Refer wiring section explained in this manual for individual IO module.

After connecting all the wires, hold all the wires together and make a neat bunch of it. Wrap a cable tie bunch so that it is firmly held in position along with terminal block. This also relieves tension on part of wire and reduces chances of loose connections.

Recommendations for digital IO modules connections:

While selecting digital IO modules, user should be aware of connection type.

For digital inputs, term sourcing and sinking is referred to the manner in which input device is wired to input module.

<p>Sink type (negative common) of input connection</p> <p>For this type of input connection, the ground of 24 Vdc supply is connected to common point on unit.</p> <p>When external input device is active (push button pressed in adjacent figure), +24 Vdc is available at input terminal on unit.</p> <p>External input device in active state supplies current to input circuit of unit. As unit is receiving current in this case, it is sink type.</p> <p>Normally, PNP type of devices (e.g. proximity switches) are connected in this fashion.</p>	
<p>Source type (positive common) of input connection</p> <p>For this type of input connection, the +24 Vdc supply is connected to common point on unit.</p> <p>When external input device is active (push button pressed in adjacent figure), current flows through input circuit of unit and passes through external input device to ground of 24 Vdc supply. As unit is supplying current in this case, it is source type.</p> <p>Normally, NPN type of devices (e.g. proximity switches) are connected in this fashion.</p>	

For digital or relay outputs, following precautions should be consider while connecting different types of loads.

<p>Noise suppressor for DC devices</p> <p>DC operated devices are protected by connecting diode.</p>	
<p>Noise suppressor for AC devices</p> <p>AC operated devices are protected by RC snubber.</p>	
<p>External fuse links or fused terminals can be recommended for relay output to avoid any burnout of internal copper modules due to excessive current flow due to external short circuit, overload or inductive surge.</p>	

[Back To Index Page](#)

4 Modular IO Configurator

[Overview: Modular IO Configurator](#)

[Steps to configure modular IO station](#)

[Steps to monitor IO data and diagnostics of a modular IO station in online mode](#)

[Special features of Modular IO Configurator](#)

[Steps to configure Header Assembly](#)

Overview: Modular IO Configurator

Modular IO Configurator is a PC based software tool for configuration of modular IO station from Mitsubishi Electric India.

Tool provides a user-friendly GUI that allows addition, removal and configuration of Header modules and IO modules in an intuitive way. After configuration and parameterization, user can download configuration data to Header module via USB interface. Then MIO configurator tool can be used to monitor IO data and diagnostic data of modular IO station.

Highlighted features:

1. Easy configuration of multiple modular IO stations in a network in single project.
2. Allows monitoring of IO data and diagnostic data of individual module at channel level.
3. Provides entire system overview briefly.
4. Facilitates testing of I/O modules without interfacing the network.
5. Generates enquiry cum bill of material.
6. Allows configuration file transfer with SDHC memory card.

Software setup requirement:

Before installing the tool, ensure that the following system requirements are satisfied.

Processor	Intel core i3 or Higher version
Disk space	200 MB
RAM memory	2GB or Higher
Screen resolution	1280 x 768 or Higher
Platform	Windows 10 (64 bit)/ Windows 11 (64 bit)
USB interface	USB 2.0

NOTE

This software incorporates open-source components that are subject to their respective licenses. It is important to review these licenses to understand your rights and obligations when using the software.

For detailed information on the open-source components included and their respective licenses, please refer to the following file located in the installation directory:

e.g. C:\Program Files (x86)\Modular IO Configuration Tool\ThirdPartyLicenses.txt

Note that the source code for these open-source components is not included in this software package.

By using this software, you agree to comply with the terms and conditions of all included open-source licenses.

Screen layout of Modular IO Configurator is as shown below.

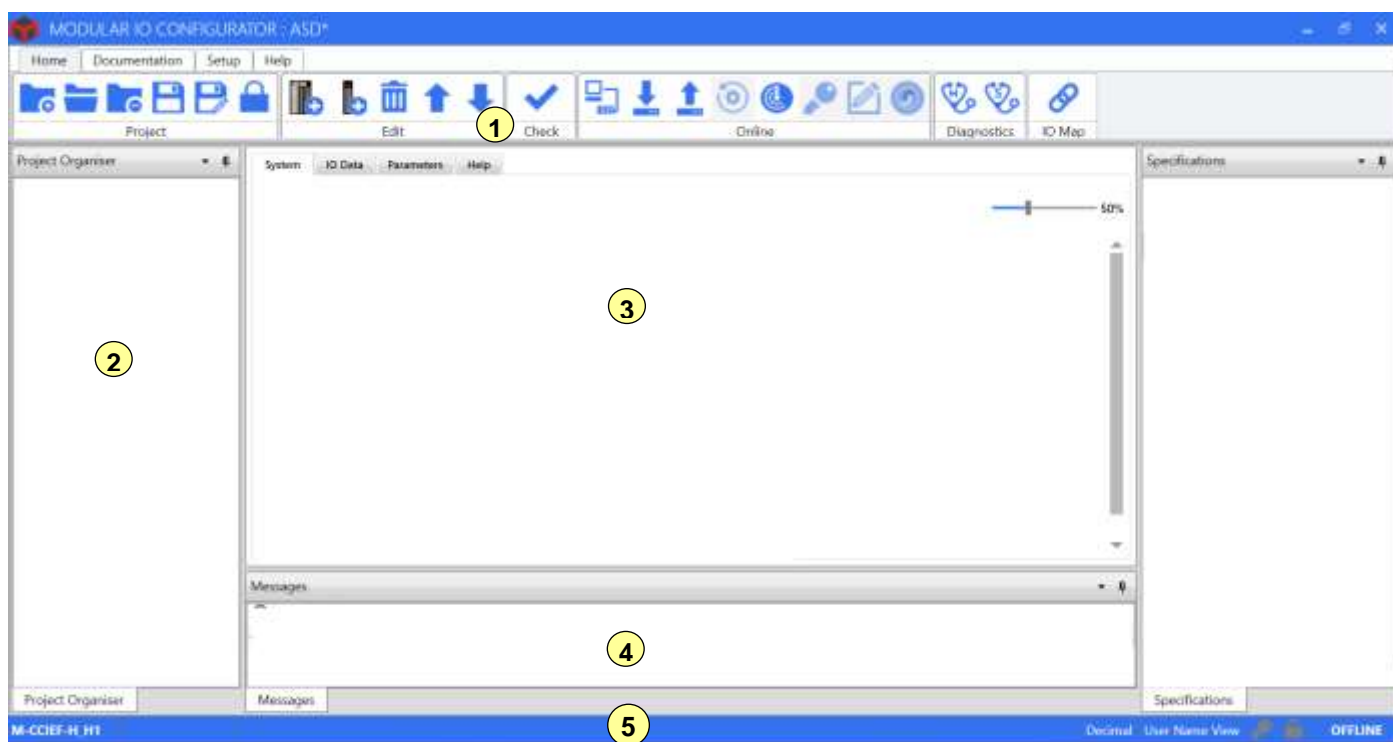

Sr. No.	Item	Description
1	Menu Bar	<p>Consists of 4 menus as below</p> <ul style="list-style-type: none"> - Home - Documentation - Setup - Help <p>Each menu provides various functions. These functions are grouped in ribbon tabs.</p>
2	Project Organiser	<p>Shows the list of added Header modules in a project in a tree view and IO modules attached to individual Header module.</p> <p>User can add or remove Header module and IO module as per the project requirement</p>
3	Working Area	<p>This is an application window which includes following four tabs,</p> <ul style="list-style-type: none"> - System - IO Data - Parameters - Help
4	Message window	<p>This window lists out various messages, which are generated by tool during operations like project creation, module deletion, project validation, online connection etc.</p>
5	Status bar	<p>Shows selected Header module, selected IO module, product view details and status of connection (offline or online), project (locked or unlocked), and output test (enable or disable).</p>



















Subsequent sections provide information of various offline functions.

1. **Menu bar:** Provides three menus with various functions.

Home: Provides functions related to creation and editing of project, validation of project and online features.



Symbol	Function	Description
	New	Create new project (<Project Name>.mio file)
	Open	Open already created project file
	Save	Save the changes done in the project
	Save As	Save the project with different project name
	Close	Close the project
	Lock/Unlock	<p>In Offline mode, if "Lock" is selected then It allows following project functions,</p> <ul style="list-style-type: none"> - Create new project - Open project - Save/ Save as project - Close the project <p>It disables following editing functions,</p> <ul style="list-style-type: none"> - Add Header - Add IO Module - Delete - Move Up/ Move Down - Station configuration checking etc. <p>In Online mode, if "Lock" is selected then It allows following online functions,</p> <ul style="list-style-type: none"> - Connection with Header - Downloading of configuration - IO data monitoring - Header and slot diagnostics monitoring - Project documentation <p>It disables following online functions,</p> <ul style="list-style-type: none"> - Uploading of configuration - Scanning of IO modules - Editing of dynamic parameters - Output test <p>Lock the project to disable editing of project to avoid accidental changes.</p>

	Add Header	Add Header module to the project It opens dialog box to choose Header module grouped by bus type and change properties
	Add IO Module	Add IO module to selected Header module. It opens dialog box to choose IO module grouped by type and change properties. IO module types are as below. <ul style="list-style-type: none"> - Digital input - Digital output - Analog input - Analog output - System module
	Delete	Delete selected module from the project
	Move Up	Shift selected Header module (along with attached IO modules) to position of previous Header module or shift selected IO module to previous slot position, after confirming station checks.
	Move Down	Shift selected Header module (along with attached IO modules) to position of next Header module or shift selected IO module to next slot position, after confirming station configuration checks.
	Check Station Configuration	Validates configuration of Header module of modular IO station for, <ul style="list-style-type: none"> - Exceeding system power consumption. - Change in field power supply. - Exceeding maximum number of IO modules supported for selected Header module. - Presence of unknown module in a Station after scan In above cases, tool provides warning message to take corrective action.
	Connect/Disconnect	Connect or disconnect the communication with Header module  Click to connect to Header module  Click to disconnect with Header module
	Download	Download the configuration to the selected Header module
	Upload	Upload the configuration from the selected Header module
	Reset	Sends reset command to the Header module. On reception of reset command, Header module resets and starts IO module identification process in similar way to that of power on of the Header module.
	Scan	Scans the IO modules attached to selected Header module. Tool can read list of IO modules [other than system modules], physically connected to the Header module. User can further modify module parameters as required. It facilitates quick configuration of modular IO station.
	Enable/ Disable Output Test	User can force output value and write to output module if “Enable Output Test” is selected. This facilitates testing of output modules locally.
	Write Values	User can write forced values to output module if output test is enabled.
	Switch Mode	Switch from control mode to standby mode. Only applicable for M-CCIEF-H header in redundancy configuration.
	Header Diagnostics	View diagnostic information of selected Header module
	Slot Diagnostics	View diagnostic information of all the slots.
	IO Map	Displays local address and fieldbus address of IO points in modular IO system.

Documentation: Provides function to generate enquiry as per enquiry scope selection i.e. either project wise or Modular IO station wise. It provides list of all the modules with ordering code, ordering description and quantity.

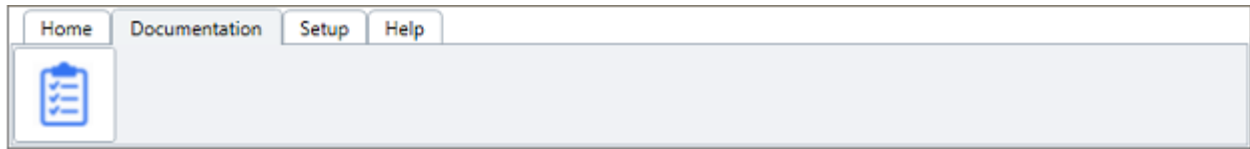

Symbol	Function	Description
	Enquiry	User can select scope of enquiry generation and then save enquiry as <Project Name>_Enquiry.csv file.

Setup: Provides functions for tool view and SD card support.

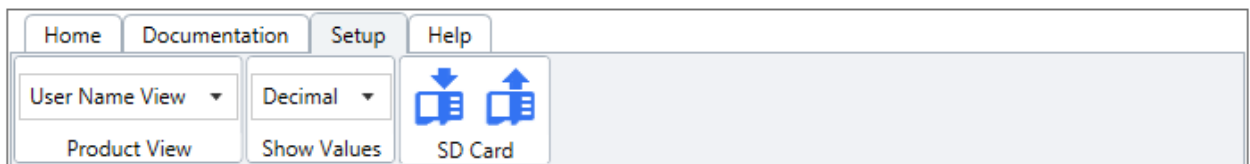

Symbol	Function	Description
--	Product View	User can view modules in tree view <ul style="list-style-type: none"> - By module ordering codes or - By user names (Default)
--	Show Values	User can monitor IO data in various number formats such as, <ul style="list-style-type: none"> - Decimal (Default) - Hex - Binary
	SD Card	User can perform following SD card related functions. <ul style="list-style-type: none"> Write to SD card Read from SD card



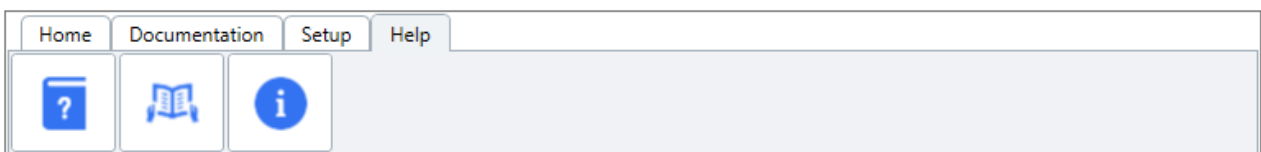



Help: Provides tool help and version info of tool.

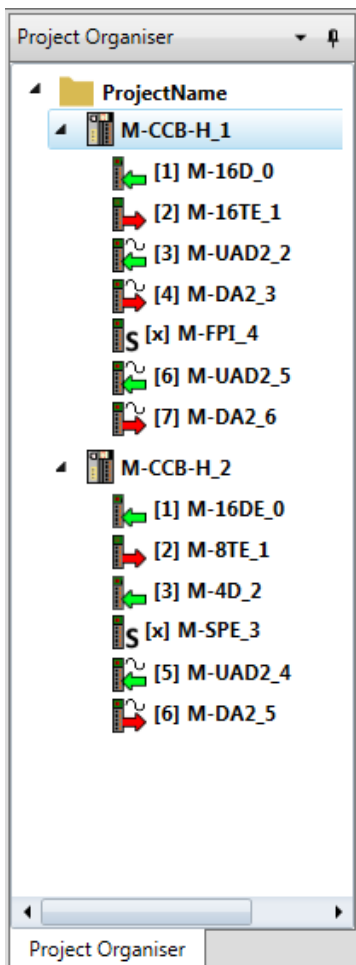

Symbol	Function	Description
	Help documents	Opens directory containing all manuals.
	User's Manual	Opens user document i.e. Modular IO User Manual.pdf
	About	Displays tool version

2. **Project Organiser:** Shows list of added Header modules and IO modules in tree view.



Item	Description
Project Name	This is user defined name of project
Header Module	Displays user defined name of Header module.  - Header module.
IO Module	Displays slot number and ordering code or user defined name of IO modules. For identification purpose, symbolic representation is provided for all types of IO modules as,  - Digital input  - Digital output  - Analog input  - Analog output  System module



NOTE

For configuration of Modular IO slave station, refer section “[Steps to configure modular IO station](#)” and for configuration of Header assembly, refer section, “[Steps to configure Header Assembly](#)”.

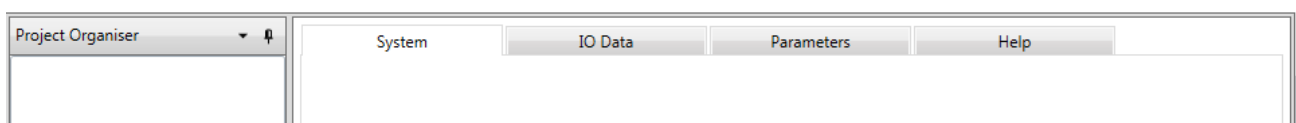
3. **Working Area:** Provides four tabs as System, IO Data, Parameters and Help.

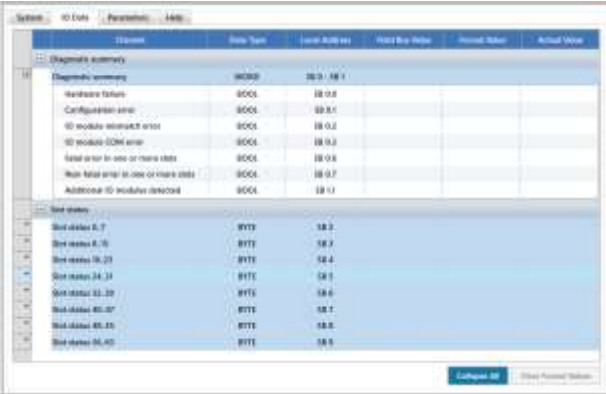

The table below provides details of each tab.

Tab	Description
<p>System</p> 	<p>This tab shows modular IO station image built as per the configuration.</p> <p>Following information is shown.</p> <ul style="list-style-type: none"> - Slot number of module Note: System modules are not intelligent modules and does not consume slot number. Hence, IO data and Diagnostics is not available. - Image of module - System current consumption of slot. - Status of module as healthy (with green color), fatal error (with red color) or non-fatal error (with yellow color). Note: Status and Error code provides online status of Header module as well as IO modules connected in station. - Error code of module. Refer section Troubleshooting --> List of Station Error Codes for more details. - Specifications of selected module in brief.
<p>IO Data</p> 	<p>This tab shows summarized diagnostics and slot wise status (SB memory) of selected Header module.</p> <p>It shows IO memory (IX, QX, IW, and QW) and diagnostic (SB memory) of selected IO module.</p>
<p>Parameters</p> 	<p>This tab provides list of user configurable parameters. Configuration parameters are grouped into two categories such as,</p> <ul style="list-style-type: none"> - Module parameters: These are common user configurable parameters specific to a module. - Channel parameters: These are user configurable parameters specific to a channel of a module.
<p>Help</p> 	<p>Shows help for selected module.</p>

1. **Message window:** List of various messages is displayed, which are generated by tool during offline operations like project creation, module deletion, project validation, etc. and online operations.

Refer section [List of Info and Error messages](#) for more details.

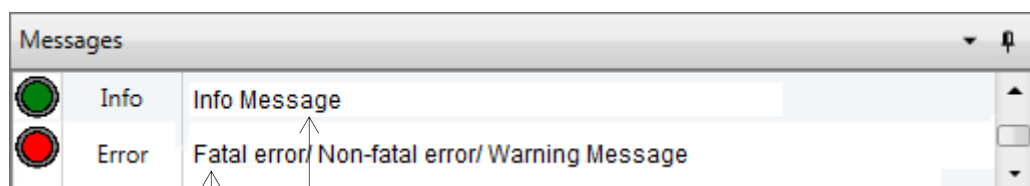

Description

Info Message:

This includes list of messages which are generated during operations like project creation, module addition or deletion etc. This is generally useful information.

Fatal error/ Non-fatal error/ Warning:

This includes list of messages which are generated after project validation and list out most important issues that may or may not cause problems in project validation or compilation.

2. **Status bar:** Shows status tabs for selected Header module, selected IO module, connection (offline or online), project (locked or unlocked), product view etc.

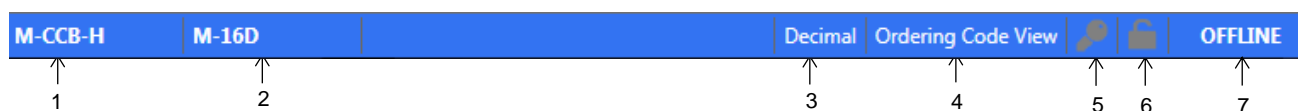

No.	Description
1	Username of selected Header module
2	Username of selected IO module
3	Format view (Decimal/ Hex/ Binary) selected to show values of IO data
4	Product view selected as Module Ordering Code View or Username View
5	Output test Enable/ Disable status.
6	Project state as locked or unlocked.
7	Project connection status as OFFLINE or ONLINE

NOTE

For configuration of Modular IO slave station, refer section [“Steps to configure modular IO station”](#) and for configuration of Header assembly, refer section, [“Steps to configure Header Assembly”](#).

4.1 Configure Modular IO Station with Header

1. Open Modular IO Configurator and view screen layout as below.

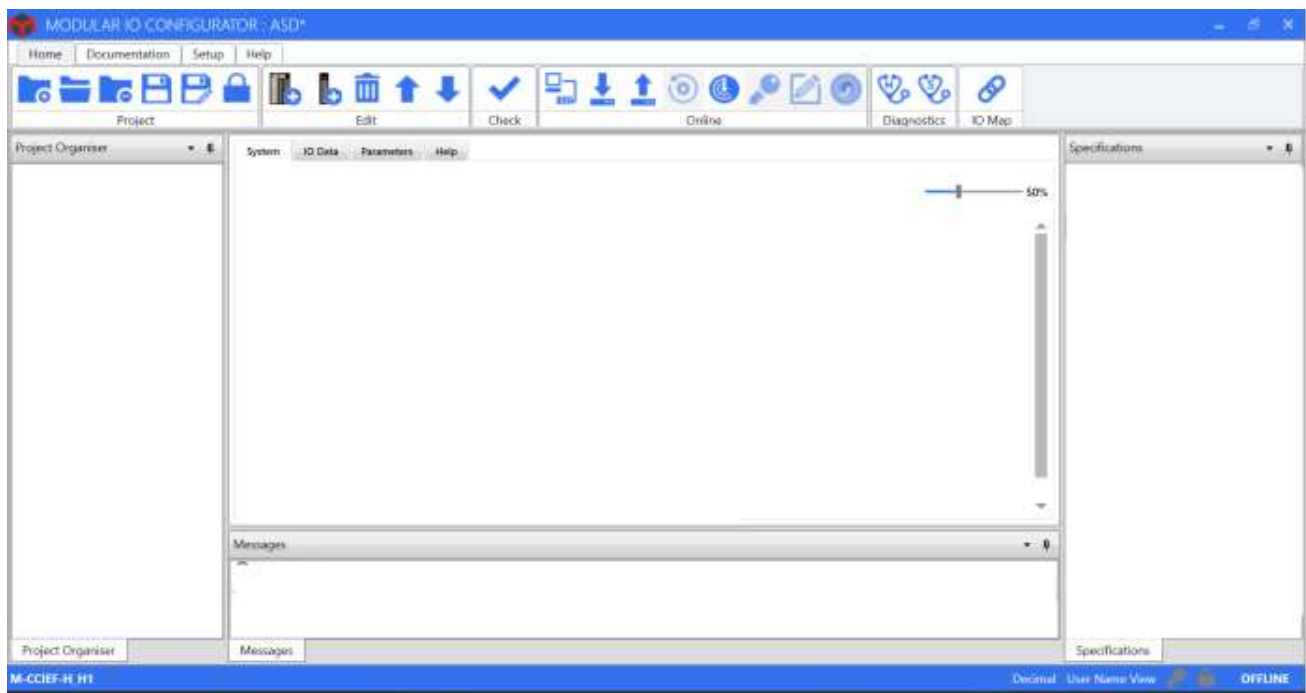

2. Click on  to create new project. This operation opens “Create Project” window.

CREATE PROJECT
✕

Project Name

Path

Bus Type

Item	Description
Project Name	Enter project name of 32-character size maximum starting with alphabet. Note: Special characters are not allowed.
Path	Select local drive path using “Browse” button to save the project file
Bus Type	Select required bus/ network type using drop-down, e.g., <i>CC Link IE Field Basic</i> , <i>Modbus TCP</i> , <i>Ethernet/IP™</i> , <i>CC Link IE Field</i> .

3. Add and configure Header module.

Click on function , this opens *Add Header* dialogue box. Select Header module and click on *Add* button.

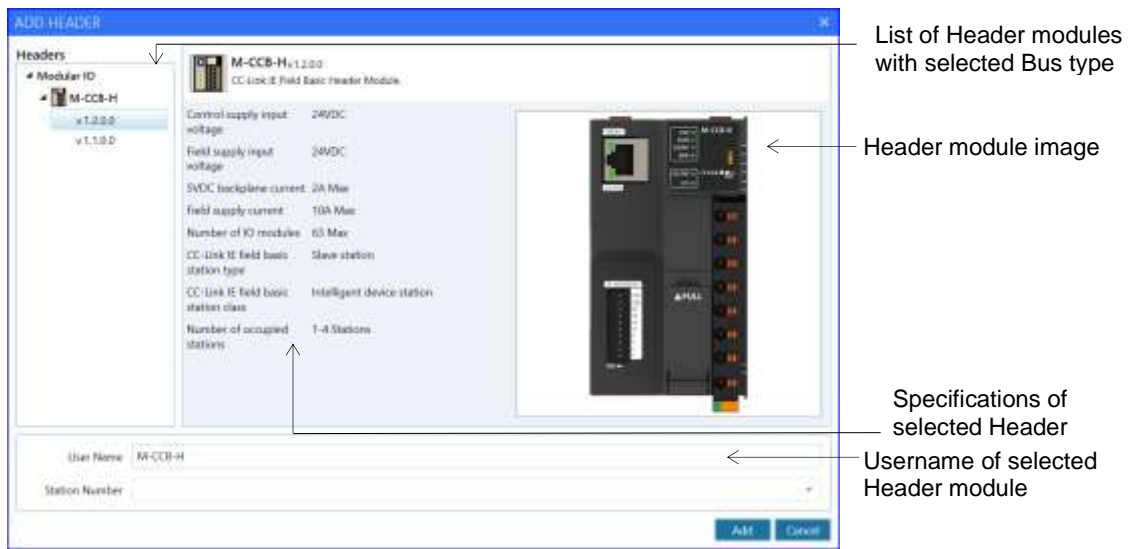

Item	Description
User Name	User defined name of 32-character size maximum starting with alphabet. By default, module ordering code is the user name.

Added Header module is displayed in tree view as well as in System tab of working area as shown below.



 *Modules are available with and without conformal coating. If module ordering code has suffix as '-C', module is with conformal coating. For example, module M-CCB-H-C, M-UAD2-C are available with conformal coating.*

 *In Modular IO Configurator Tool, module with and without conformal coating is identical. For example, to configure module M-CCB-H or M-CCB-H-C, configure module M-CCB-H.*

- Select Header module from Project Organiser window and click on “Parameters” tab to set Header configuration parameters. User can modify Project Values for individual parameter.

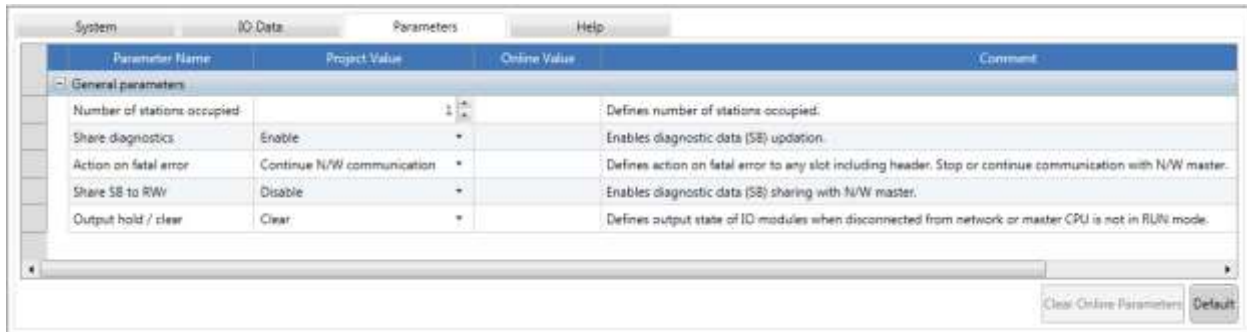

Above parameters are specific to CC-Link IE Field Basic Header module (M-CCB-H) and shown for an example.

- Click on tab “IO data” to view diagnostic (SB memory) of Header module.

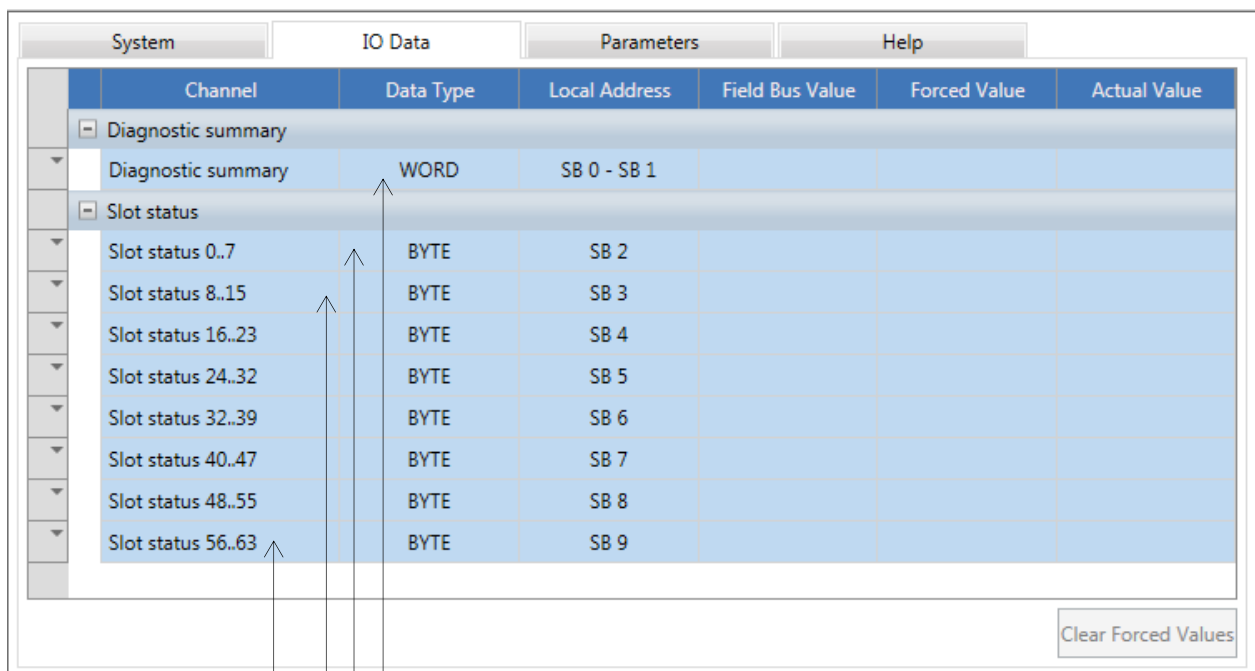

Item	Description
Diagnostic summary	Holds summarized Header diagnostics
Slot status 0..7	Holds slot wise status of IO module, configured in slot 0 to slot 7.
Slot status 8..15	Holds slot wise status of IO module, configured in slot 8 to slot 15.
Slot status 16..23	
Slot status 24..32	
Slot status 33..39	
Slot status 40..47	
Slot status 48..55	
Slot status 56..63	Holds slot wise status of IO module, configured in slot 56 to slot 63.

Refer section [M-CCB-H: IO Data](#) for more details.

6. Add and configure IO module to modular IO station, as below.

Click on function  to open dialog box of “Add Module” which shows list of IO modules grouped as per IO module type.

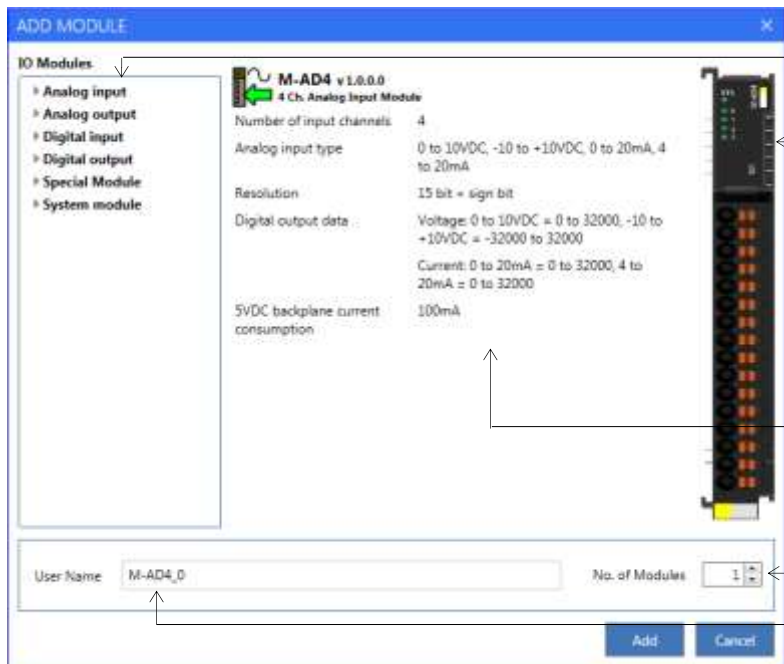

List of supported IO modules

IO module image

Specifications of selected IO module

Add multiple number of modules of selected IO module at a time.

Username of selected IO module

Item	Description
User Name	User defined name of 32 characters size maximum starting with alphabet By default, module ordering code is the user name.

Added IO module is displayed in tree view as well as in System tab in working area as shown below.

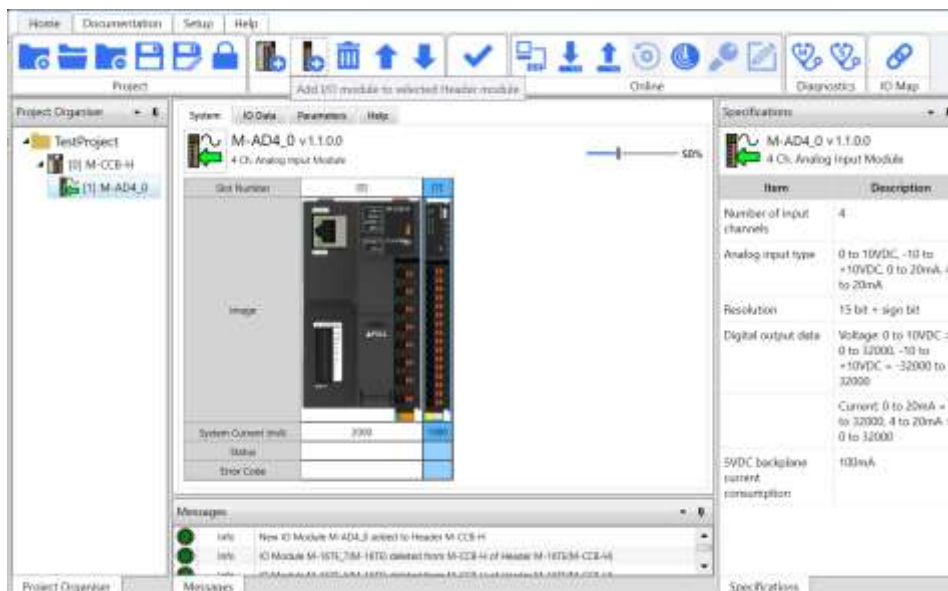

 Modules are available with and without conformal coating.
If module ordering code has suffix as '-C', module is with conformal coating.
For example, module M-CCB-H-C, M-UAD2-C are available with conformal coating.

 In Modular IO Configurator Tool, module with and without conformal coating is identical.
For example, to configure module M-CCB-H or M-CCB-H-C, configure module M-CCB-H.

Add number of IO modules as required to form a modular IO station as per the application requirement.

When system power consumption by IO modules exceeds capacity of Header module, tool prompts user to add System Power Extension module (M-SPE) and then add IO modules further.

User should add other system modules as per the wiring and station requirements.

In a typical fieldbus system, there are number of modular IO stations connected. User can add number of Header modules and then attach IO modules to each Header module and save project as a single project.

NOTE

Digital and Analog IO modules are intelligent modules and provide IO data and diagnostics. System modules are passive modules and do not provide any IO data and diagnostics. Hence, Header module cannot detect presence of system modules and cannot assign slot position.

7. Select IO module from Project Organizer window and click on “Parameters” tab to set module as well as channel parameters.



Parameters shown are specific to 2 Ch Universal Analog Input module (M-UAD2) and shown for an example.

Channel level parameters can be edited by expanding CH0 parameters and CH1 parameters.

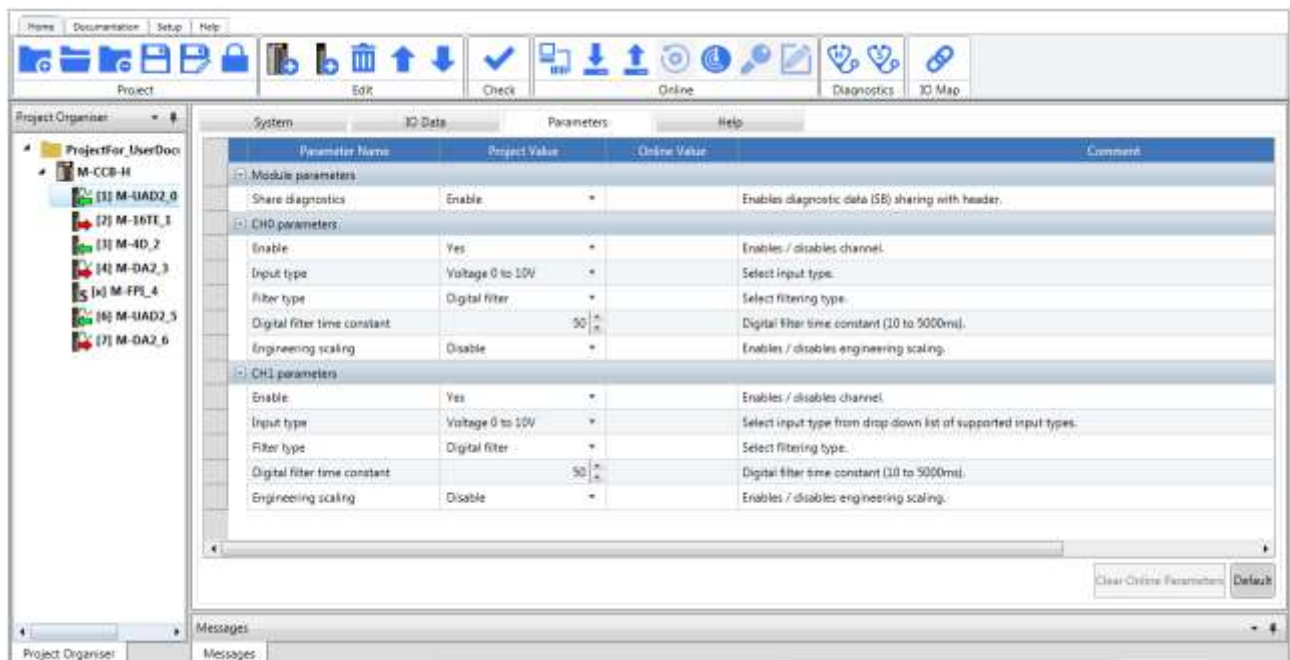

8. Similarly, configure parameters of all the modules by selecting individual module in tree view and respective parameters tab.
9. User should attach Bus End module (M-BE) at the last slot position if there are 16 or more IO modules.
10. Connect Header module to your PC via standard USB 2.0 cable.

11. Click on  to download the configuration to connected Header module. This pop ups progress window as shown below. After successful downloading, click Ok.



4.2 Configure Modular IO station with Header Assembly

For configuration of header modules like M-CCIEF-H, user should configure Header assembly as explained below,

1. Open Modular IO Configurator and view screen layout as below.

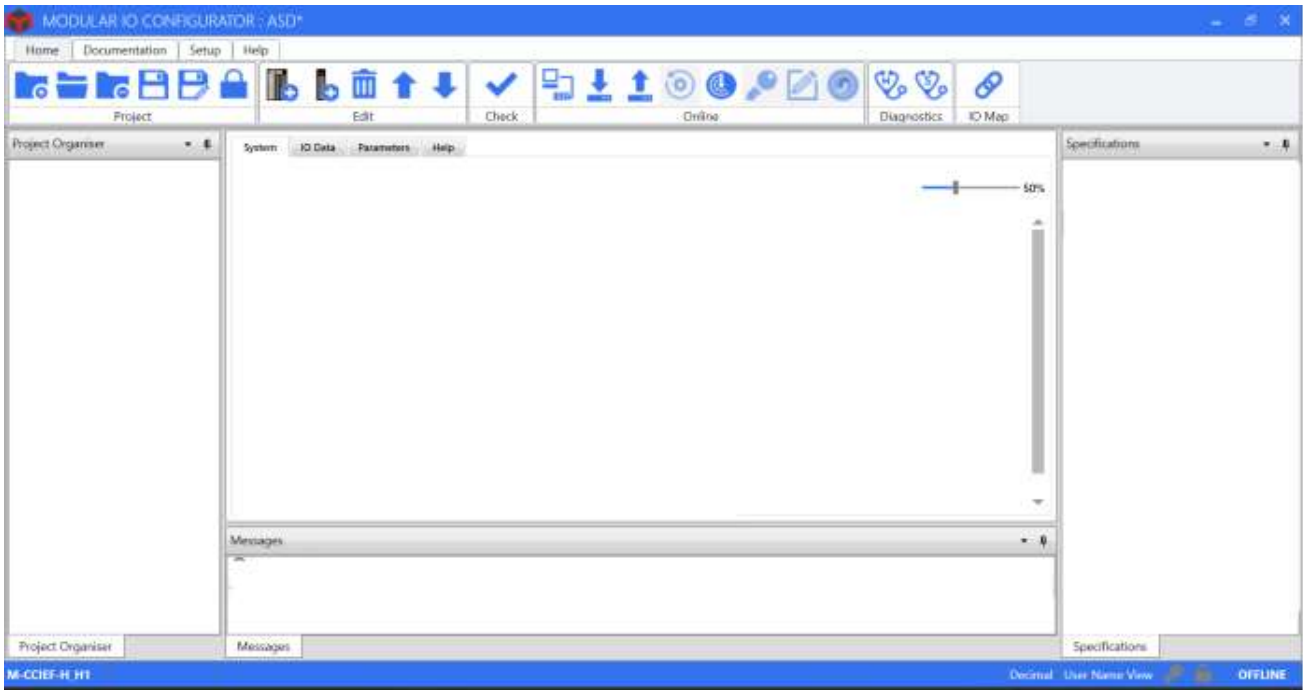

2. Click on  to create new project. This operation opens “Create Project” window.

CREATE PROJECT
✕

Project Name

Path
 Browse

Bus Type

Create
Cancel

Item	Description
Project Name	Enter project name of 32-character size maximum starting with alphabet. Note: Special characters are not allowed.
Path	Select local drive path using “Browse” button to save the project file
Bus Type	Select required bus/ network type using drop-down, e.g. <i>CC Link IE Field</i> .

3. Add and configure Header module.

Click on function , this opens *Add Header* dialogue box. Select Header module and click on *Add* button.

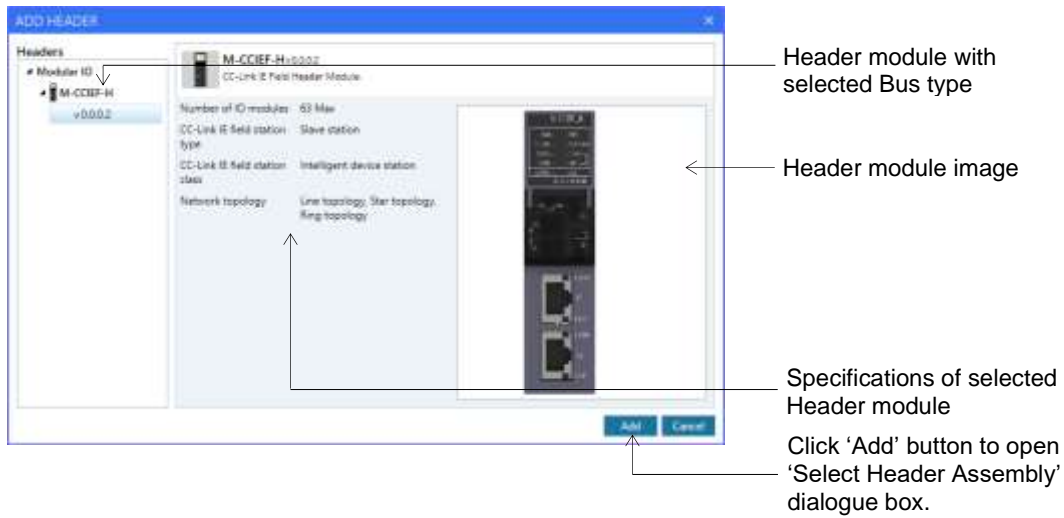

4. Select Header assembly with 2 slots/ 3 slots/ 5 slots base modules. Add User Name for selected assembly base module and click on 'Select' button.

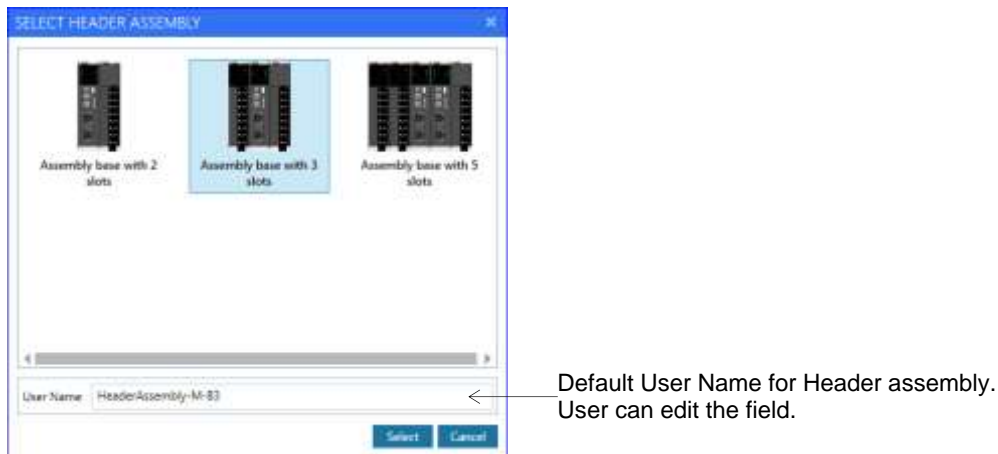

5. Dialogue *Configure Header Assembly* is opened as shown below.



Header assembly is displayed in tree view as well as in System tab of working area as shown below.

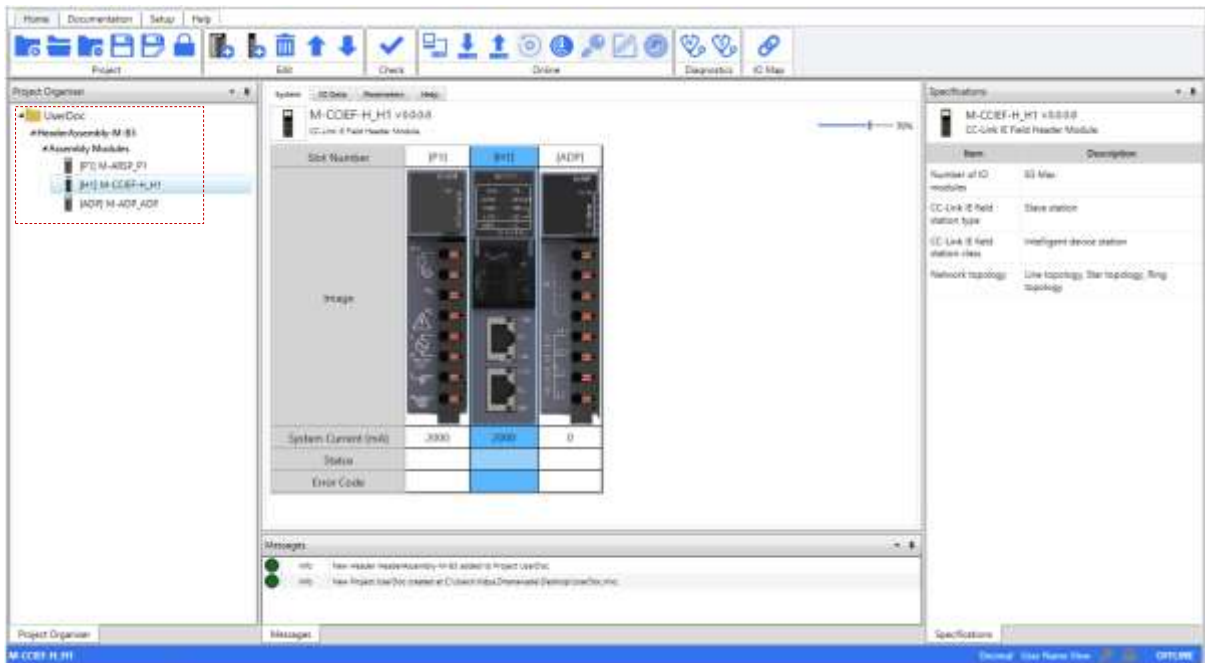

6. Select Header module from Project Organizer pane and click on “Parameters” tab to set Header configuration parameters. User can modify Project Values for individual parameter.



Above parameters are specific to CC-Link IE Field Header module (M-CCIEF-H) and shown for an example.

7. Click on tab "IO data" to view diagnostic (SB memory) of Header module.

Channel	Data Type	Local Address	Field Bus Value	Forced Value	Actual Value
- Diagnostic summary					
Diagnostic summary	WORD	SB 0 - SB 1			
- Slot status					
Slot status 0..7	BYTE	SB 2			
Slot status 8..15	BYTE	SB 3			
Slot status 16..23	BYTE	SB 4			
Slot status 24..32	BYTE	SB 5			
Slot status 32..39	BYTE	SB 6			
Slot status 40..47	BYTE	SB 7			
Slot status 48..55	BYTE	SB 8			
Slot status 56..63	BYTE	SB 9			

Item	Description
Diagnostic summary	Holds summarized Header diagnostics
Slot status 0..7	Holds slot wise status of IO module, configured in slot 0 to slot 7.
Slot status 8..15	Holds slot wise status of IO module, configured in slot 8 to slot 15.
Slot status 16..23	
Slot status 24..32	
Slot status 33..39	
Slot status 40..47	
Slot status 48..55	
Slot status 56..63	Holds slot wise status of IO module, configured in slot 56 to slot 63.

Refer section [M-CCIEF-H: IO Data](#) for more details.

For adding and configuration IO modules in Header assembly, refer section [Configure Modular IO Station with Header >> Add IO Module](#).



Add number of IO modules as required to form a modular IO station as per the application requirement.

Connect Header module to your PC via standard USB 2.0 cable.

8. Click on  to download the configuration to connected Header assembly. This pop ups progress window as shown below. After successful downloading, click Ok.



4.3 Monitor IO Data and Diagnostics

1. Click on function  to connect to Header module. Icon changes to  and Status bar is updated as ONLINE.
2. Select Header module in Project Organizer window and click on tab "IO data" to monitor diagnostics (SB memory) of Header module.

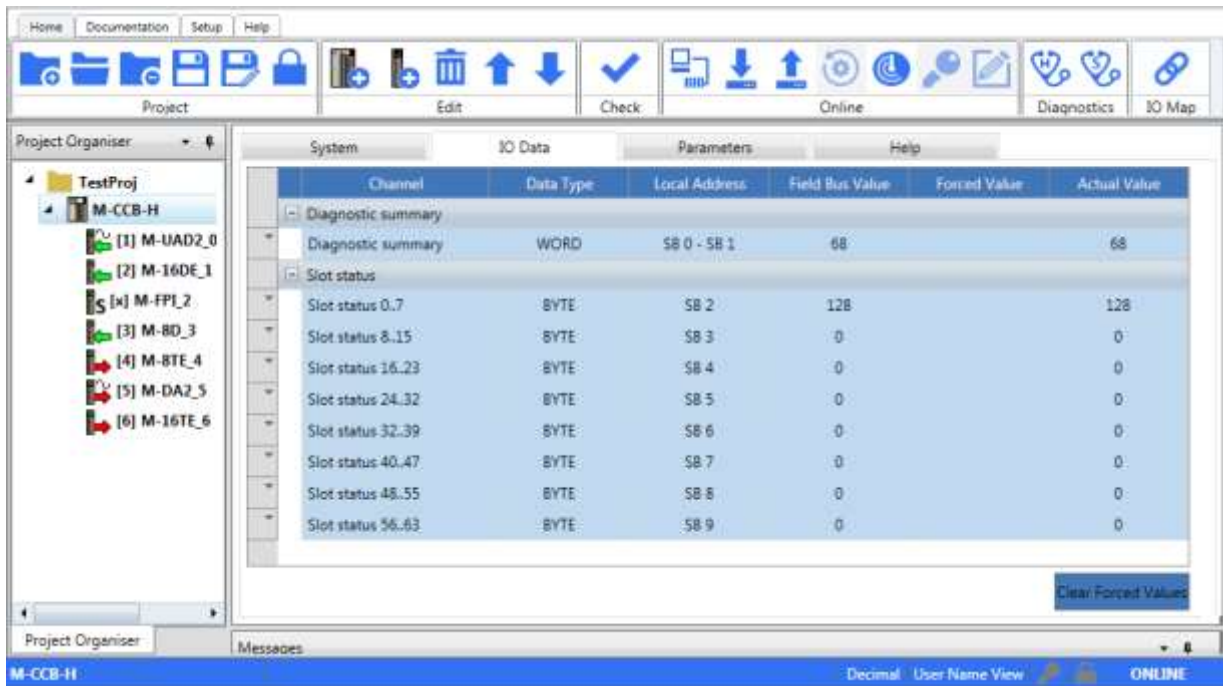

Field Bus Values can be monitored in Decimal/ Hex / Binary format by selection in menu Setup → Show Values.

3. Further, bit wise diagnostic summary and slot wise status can be monitored by expanding individual channel. Select IO module in Project Organizer window and click on tab "IO data" to monitor IX, QX, IW, QW and diagnostics (SB memory) of selected IO module.

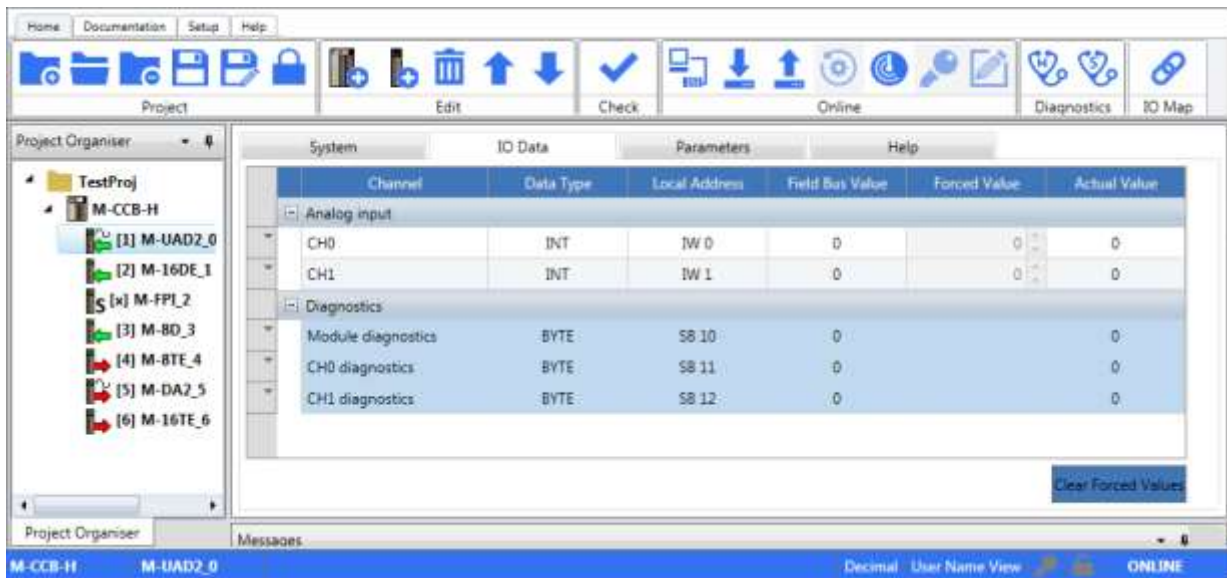

NOTE

Field Bus values shows the values available with network Master and normally, Field Bus values and Actual values are identical for input and output. User can force output values and write to actual output values when Output test is enabled. In such case, Forced Values and Actual Values become identical. For more details, refer section "Output test in online monitoring mode".

4.4 Special Features

[Modular IO Configurator]

Scan IO modules

Output test

Header diagnostics and slot diagnostics

Unknown module

Module versions

Configuration transfer with SDHC memory card

Enquiry generation

Scan IO modules:

Tool facilitates quick configuration of a modular IO station if setup is available with IO modules actually attached to the Header module. Using “Scan IO Module” function, tool can read the list of IO modules (other than system modules) physically attached to the Header module.

Select Header module and click on Online function  This opens following window of Scan IO Modules.

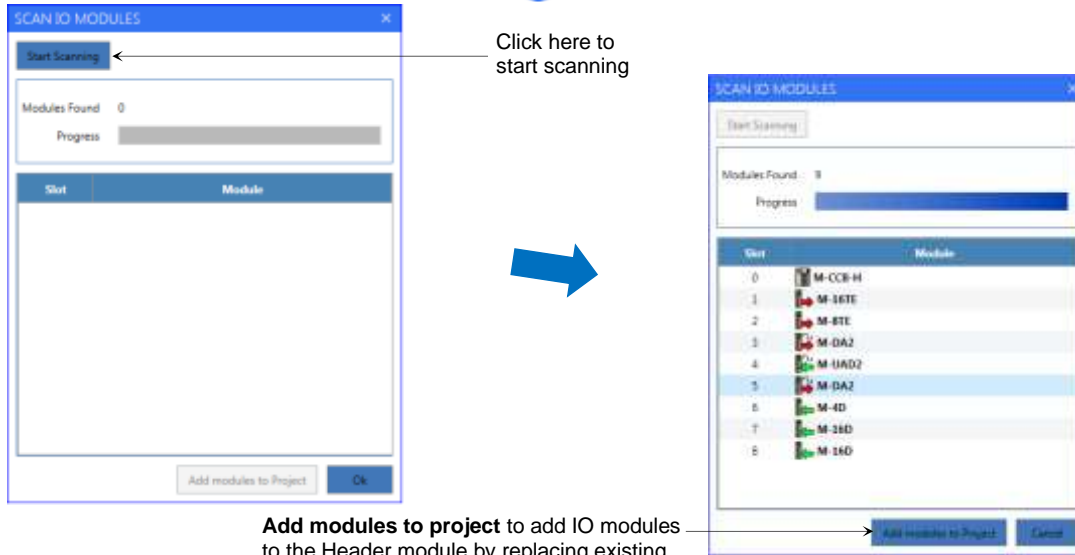

NOTE

System modules are passive modules. Hence, Header module cannot detect presence of System modules in a modular IO station. So System modules do not appear in the list after scan.

After scanning and adding modules successfully to project, system tab gets updated as shown below.



NOTE

After scanning IO modules, if mismatched module is detected then tool pops up error window which can guide user to perform further actions.





Output test:

This is online feature and useful to test output module locally even when Header module is not connected to the fieldbus/ network. User can write individual output (True/ False to digital output module and channel data to analog output module) and test individual output.

NOTE

Output test is possible only if modular IO station is healthy. Confirm status of modular IO station using LED indications on Header module. Refer section [LED Indications](#) for more details.

Follow the steps as below, to write outputs for test purpose.

1. Click on function  to connect to Header module. Icon changes to  and Status bar is updated as ONLINE.
2. Enable output test by clicking on function . Icon changes color to red  and updates status on status bar. This allows user to write force output values to actual output values.
3. When Output test is enabled, IO LED on Header module turns yellow.
4. Select output module to test output.
5. Select "IO Data" tab.
6. Select individual output DO nn (for Digital output) or CHn (for Analog output).
7. Select option as
 - Force to true/ Force to False/ No Force for Digital output and
 - Enter value between -32768 and 32767 for Analog output.
 - Color of Forced values change to red.
8. Repeat step 7 for other output module as required.
9. Click on Online function  to write Forced values to Actual values. Forced value overwrites Field bus values. After writing output values to actual values, color of Forced values changes to blue.
10. Change in digital output is indicated by output LED indication on the digital output module. User can measure actual output signal to test digital output and analog output.

NOTE



Forcing of output continues as long as modular IO station is powered on and in ONLINE monitoring mode. When user tries to go OFFLINE, tool prompt user to clear forced values.

For digital output and analog output, functions “Enable/ Disable output test”  and “Write values”  are used as shown below.

For digital output:

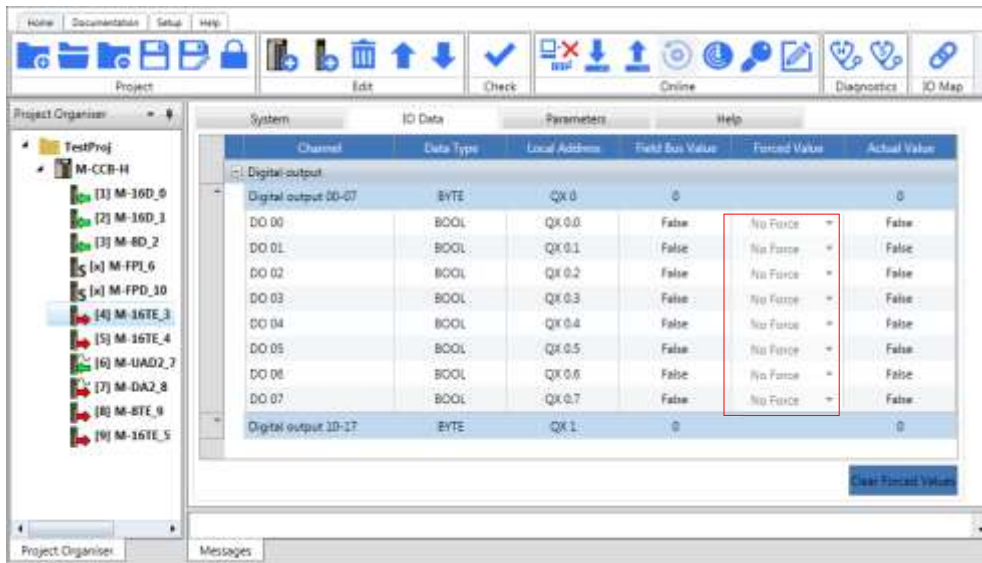
In online monitoring mode, select digital output module, here M-16TE is selected as an example. By default, forcing of output is disable.



Click on function  Icon changes color to red . This enables output test feature and allows forcing of individual output as shown.

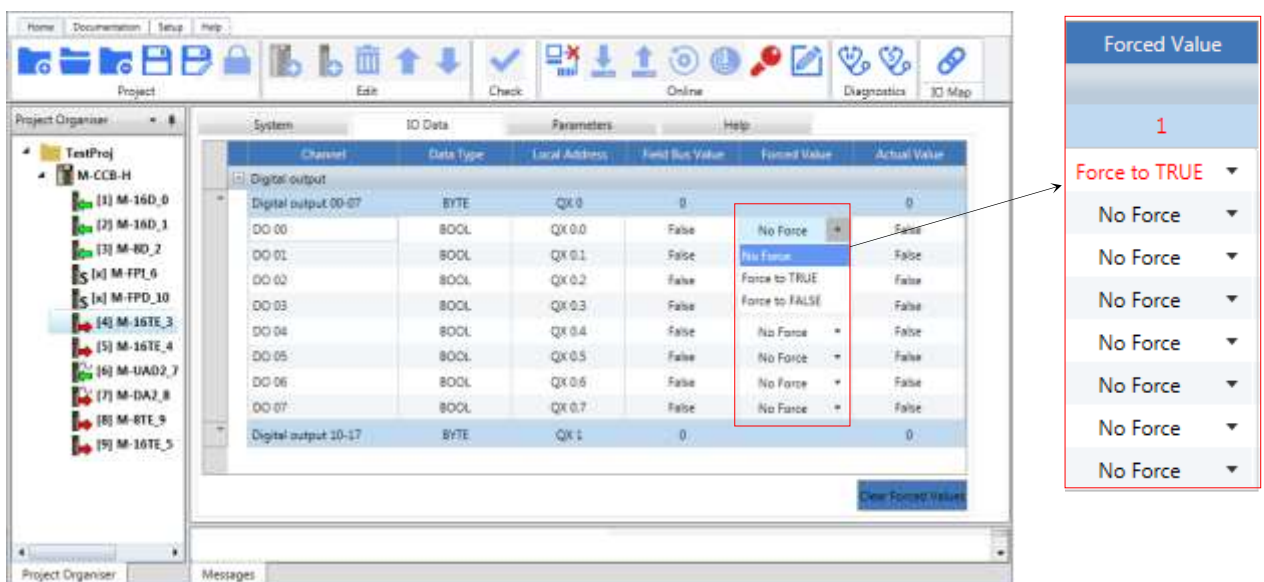

After selection of either Force to TRUE or Force to FALSE, online changed force value for output turns red as shown above.



Clicking on function  writes online changed force value to actual value and force value changes color as blue as below.

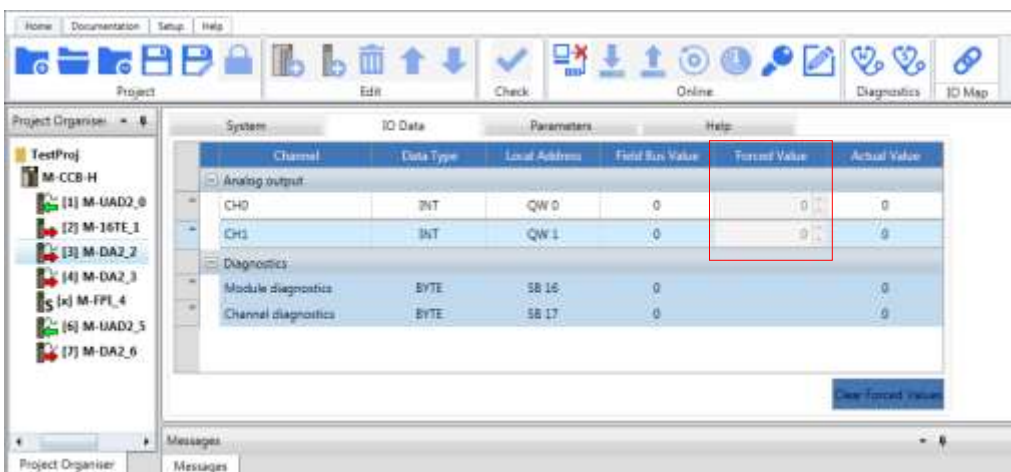

For analog output:

In online monitoring mode, select analog output module, here M-DA2 is selected as an example. By default, forcing of output is disable.



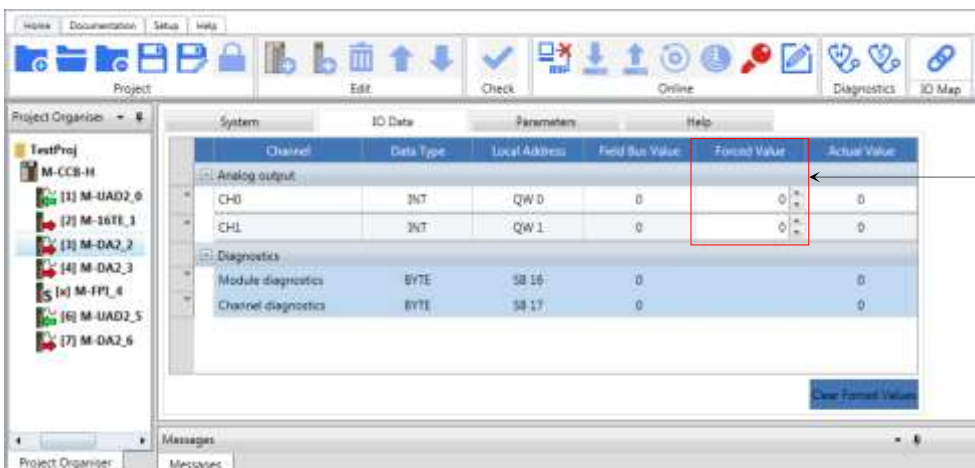

Click on function  It enables output test and function symbol becomes  It allows user to write count at individual output channel.

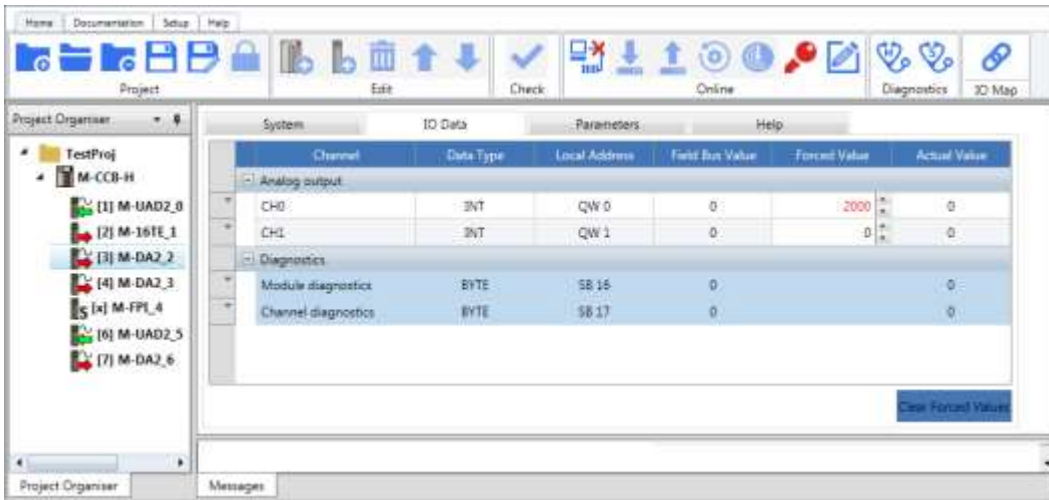

Click on combo button to change count at output CH0 and CH1 from “-32768 to 32767 or directly enter value

After changing count, online changed count turns red as shown



Click on function  to write online changed count to actual value and force value changes color as blue as below.

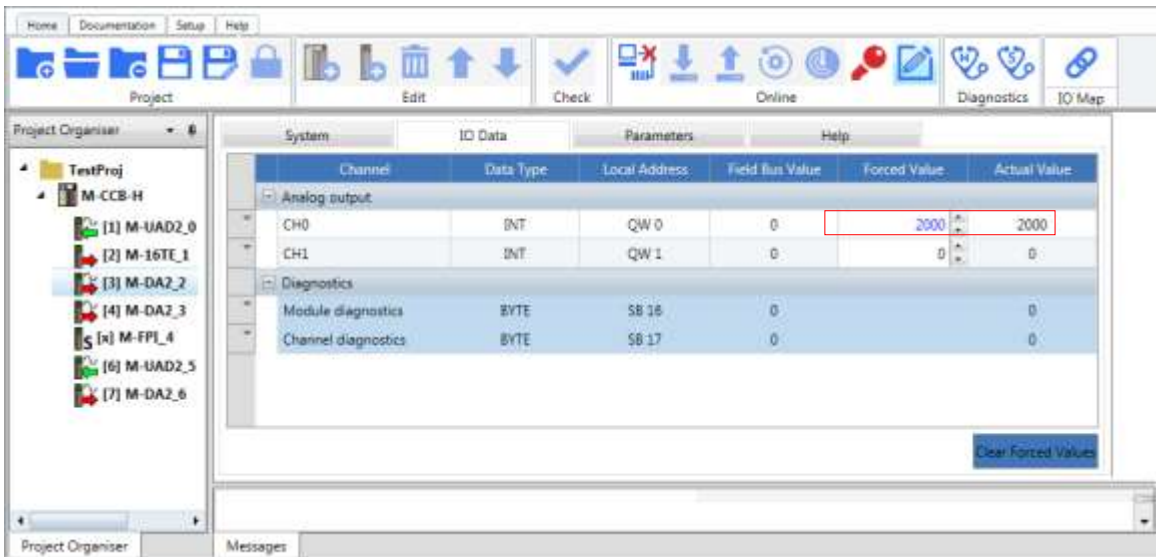

NOTE

If user tries to write invalid forced value, then it is not written successfully and remains in red color.

Header diagnostics and slot diagnostics:

This is online feature and useful to monitor details of Header diagnostics and slot diagnostics.

Header diagnostics

Header diagnostic information provides detailed diagnostics related to header module.

Header diagnostics covers information related to identification, version information, result of self-diagnostics tests, status of switches and LEDs on header module, memory consumption, scan time, bitwise status of each IO module configured, detailed diagnostics of fieldbus communication etc.

To access header diagnostics, click on “Header Diagnostics”  button in ‘Diagnostics’ group of toolbar in online mode. This pops up following window of “HEADER DIAGNOSTIC INFORMATION”.



Diagnostics	Value	Description
Identification :		
Vendor code	1	Vendor code of manufacturer.
Ordering code	M-CCB-H	Ordering code of header module.
Serial number		Serial number of header module.
Version Info		
Device version	0.0.0.11	Device version of header module.
Hardware version	1.0.0.0	Hardware version of header module.
Firmware version	0.0.0.11	Firmware version of header module.
Backplane bus version	0.0.0.8	Backplane bus version of header module.
Hardware		
IP setting		
IP address	192.168.3.1	Header IP address.
Subnet mask	255.255.255.0	Subnet mask.
MAC ID	58-52-8A-81-D0-01	Header MAC ID.
Memory size		
Header scan time		
Current	0	Header scan time.
Maximum	14	Maximum header scan time.
Minimum	0	Minimum header scan time.
Diagnostic Summary		
Slots 0-15		
Detected	1111111111110000	Bitwise module detection status.
Healthy	0111110000110000	Bitwise module health status.

For details of information shown in header diagnostics information dialogue, refer to section ‘Header diagnostics’ of individual header module.

Slot Diagnostics

Slot diagnostic provides detailed information of configured module and present modules in each slot of modular IO station. Detailed information includes ordering code and version information of configured and present module, detailed version information of hardware, firmware, details of error code detected for each slot.

To access slot diagnostics, click on “Slot Diagnostics”  button in ‘Diagnostics’ group of toolbar in online mode. This pops up following window of “SLOT DIAGNOSTIC INFORMATION”.



Slot	Vendor	Configured Module	Present Module	Ver. Configured Module	Ver. Present Module	HW Ver.	FW Ver.	Backplane Ver.	Error
0	1	M-CCB-H	M-CCB-H	0.0.0.4	0.0.0.11	1.0.0.0	0.0.0.11	0.0.0.8	0000
1	1	M-16D	M-16D	1.0.0.0	1.0.0.0	1.0.0.0	1.0.0.0	0.0.0.2	0000
2	1	M-16D	M-16D	1.0.0.0	1.0.0.0	1.0.0.0	1.0.0.0	0.0.0.2	0000
3	1	M-8D	M-8D	1.0.0.0	1.0.0.0	1.0.0.0	1.0.0.0	0.0.0.2	0000
4	1	M-16TE	M-16TE	1.0.0.0	1.0.0.0	1.0.0.0	1.0.0.0	0.0.0.2	0000
5	1	M-16TE	M-16TE	1.0.0.0	1.0.0.0	1.0.0.0	1.0.0.0	0.0.0.2	0000
6	1	M-UAD2	M-UAD2	1.0.0.0	1.0.0.0	1.0.0.0	1.0.0.0	0.0.0.2	0000
7	0	M-DA2	M-DA2	1.0.0.0	0.0.0.0	0.0.0.0	0.0.0.0	0.0.0.0	0000
8	0	M-8TE	M-8TE	1.0.0.0	0.0.0.0	0.0.0.0	0.0.0.0	0.0.0.0	0000
9	0	M-16TE	M-16TE	1.0.0.0	0.0.0.0	0.0.0.0	0.0.0.0	0.0.0.0	0000

List of user names of Header module and IO modules configured.

List of user names of connected Header module and IO modules physically attached to the Header.

Hardware versions of present modules.

Firmware version of present modules

Error code of individual module along with error description in tool tip

NOTE

For header assembly modules, slot diagnostics of individual slots (P1, P2, H1, H2 and ADP) is available. For system modules, only information of configured module is shown, present information is shown as 'x'.

Unknown module:

Tool declares 'Unknown module' error if module in project is not supported by tool. Unknown module is indicated as shown in below



In this case user must update 'Modular IO Configurator Tool' to latest version.

Module versions:

Multiple versions of modules are supported in configurator tool [V1.6.0.0] or later.

Refer file 'N16001AAMH02 Modular IO Version Information' for details of module versions of headers and IO modules in Modular IO system.

NOTE

Project created using older configurator tool (V1.5.0.0 and lesser) are compatible with newer versions.

NOTE

Project created using configurator tool supporting multiple module versions (V1.6.0.0 or later) may open in older versions of tool but it will change module versions in project without any warning. Project data like configuration parameters etc. will get lost in such cases.

Add modules

While creating new project, user can choose modules from different available versions in configuration tool. While adding new header or module, tool shows available device versions of the module as shown below.



By default, latest version of module will get selected.

Select module version from the list and click Add button to add module of selected module version in project.

Version check while connecting to header

While communicating to target header (for scan, upload, download, connect etc.), configurator tool compares version of header added in project. If header version of target header is older than one configured in project then connection to header is aborted with message,

Configured header version '1.1.0.0' is incompatible with target header version '1.0.0.0'. Connection to header aborted

Where,

1.1.0.0: Version of header added in project.

1.0.0.0 : Version of target header

In this case user must change version of header module in project.

To change version of header, right click on header in Project Organiser and select option 'Change Version'.

Change version dialogue will appear as shown below.

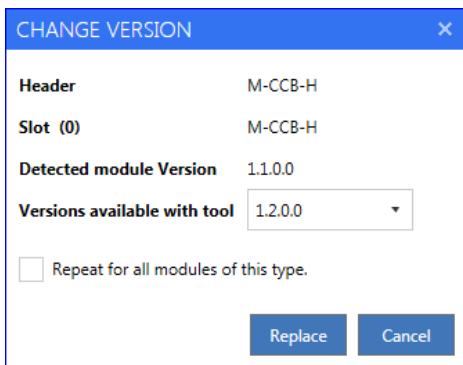

Open existing project or uploaded project

While 'Opening project' or 'Uploading project' from header, tool compares version of modules in project with versions available with tool.

Following errors can be occur during device version comparison.

Unknown module detection:

Refer section "[Unknown module](#)" for more details.

Version mismatch detection:

Tool declares version mismatch, if module from project is supported by tool but module version in opened or uploaded project is not available with tool.

Version mismatch indicated as shown below.

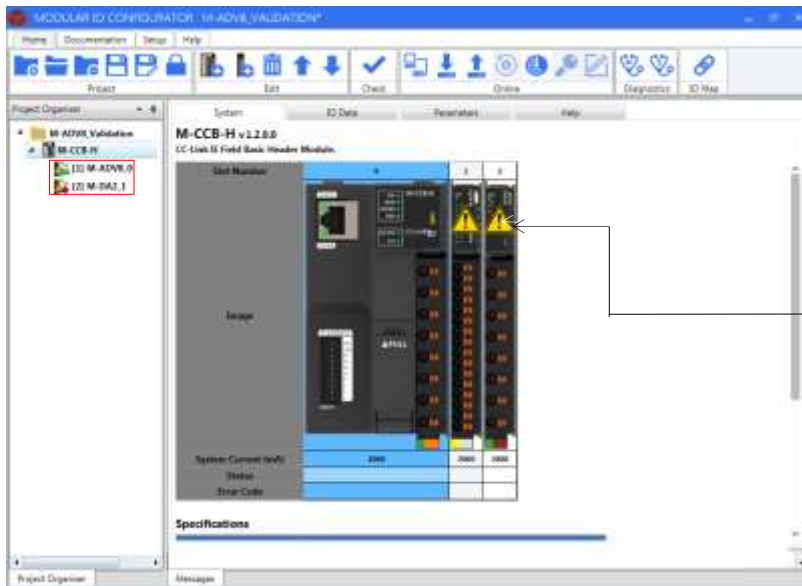

 Symbol indicates module mismatch.

This can happen because project being opened or uploaded is created with newer version of Configurator tool.

NOTE

Slot diagnostics shows version information of connected IO modules.

In this case, following actions can be performed,

- User can update 'Modular IO Configurator Tool' to latest version. Latest Configurator tool will support all versions of module.
- User can change module version in project to one which is available with tool.

To change module version, right click on module with version mismatch in "Project Organiser" window and select 'Change Version' as shown below.

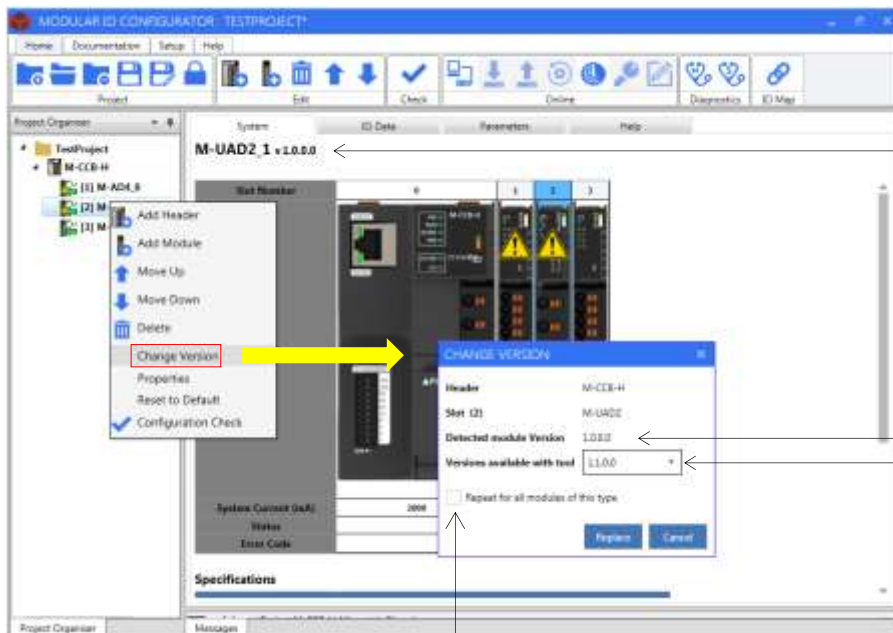

Configured device version is displayed along with module ordering code.

Device version of configured module.

Drop list of available device versions of selected module.

Check the box to change device version of all the modules of same ordering code in the project.

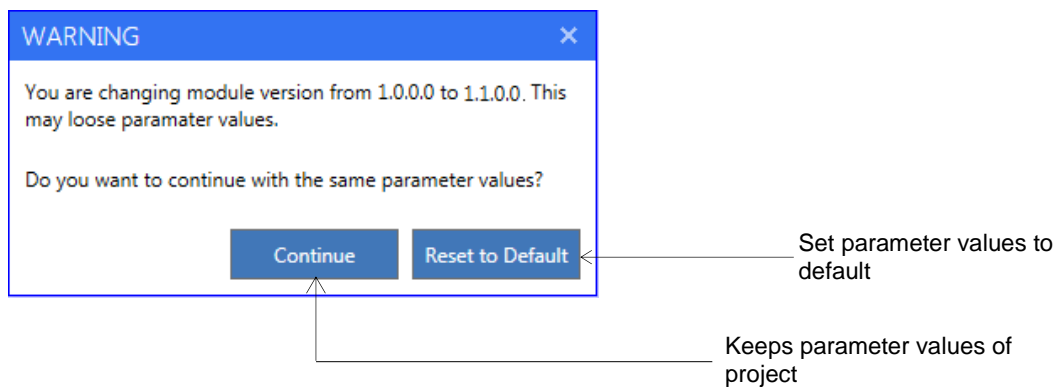

Warning is displayed when click on "Replace" button.



Configuration transfer with SDHC memory card:

Tool supports configuration file transfer to/from SD card. This function is useful to store configuration file backup and transport configuration file to the End user.

Setup menu provides SD card related functions.

- Write to SD Card 
- Read from SD Card 

NOTE

Insert SD card formatted with FAT32 file format in card reader for Read/ Write operation.

1. **Write to SD Card:** It opens “SD CARD WRITE” window.

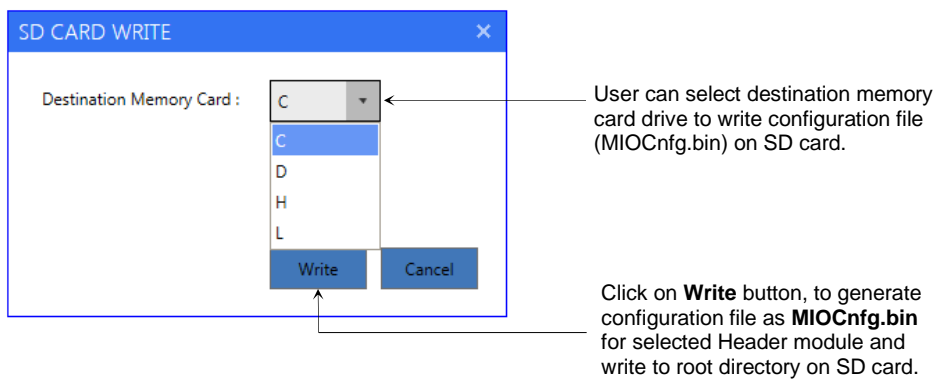

Error and warning messages popped up during “Write to SD card” operation as listed below.

Message Type	Display message	Occurrence
Error	Invalid configuration	If tries to write invalid configuration file
	Destination drive is not formatted with FAT32. Format drive and try again.	If selected removable destination drive is not formatted with FAT32 file format.
	Destination drive is not available	SD card is not inserted in reader device
	Destination drive is not removable	If selected “Destination memory card” is not removable.
	Insufficient memory available in selected drive	If space available on selected removable drive is less than 192 Kbytes.
Warning	Modular IO configuration file is already present at destination, do you want to replace?	If MIOcnfg.bin is already present on SD card.
In Message window of “Modular IO Configurator”		
Info	Start of SD card write	Configuration file transfer is initiated
	SD card write successful	After successful file transfer from tool to SD card
Error	Invalid SD card format	Tool checks file system of destination drive
	SD card write unsuccessful	Tool checks whether configuration file writing is successful or not.

2. **Read from SD Card:** It opens “SD CARD READ” window.

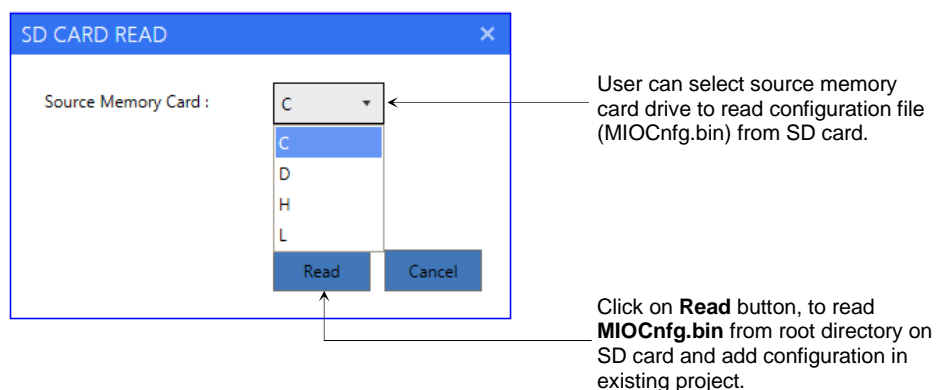

Error and warning messages popped up during “Read from SD card” operation as listed below.

Message Type	Display message	Occurrence
Error	Source drive is not formatted with FAT32. Format drive and try again.	If selected source removable drive is not formatted with FAT32 file format.
	Configuration file is not available in source drive.	If configuration file is not present in source drive or configuration file name in source drive is other than “MIOcnfg.bin”
	Header ordering code in configuration file does not match with selected header. Selected Header: [Ordering code] Configuration file: [Ordering code]	If Header types configured in tool (.mio project file) and defined in MIOcnfg.bin are different.
	Header username [username] in configuration file is already present in project. Cannot add configuration from SD card. Change header name and try again.	If header user names in MIOcnfg.bin on SD card and in project are identical
	Source drive is not available	SD card is not inserted in reader device
	The selected drive is not removable	If selected “Source memory card” is not removable
In Message window of “Modular IO Configurator”		
Info	Start of SD card read	Configuration file transfer is initiated
	SD card read successful	After successful file transfer from SD card to tool
Error	Invalid SD card format	Tool checks file system of destination drive
	SD card read unsuccessful	Tool checks whether configuration file writing is successful or not.

Enquiry generation (in .csv file format):

This is offline feature and useful to generate enquiry document for user in .csv file format.

Generated enquiry document covers list of ordering codes along with description and quantity of modules. Follow the steps below.

1. Click on function  on Documentation tab. This pops up ENQUIRY window as shown below.

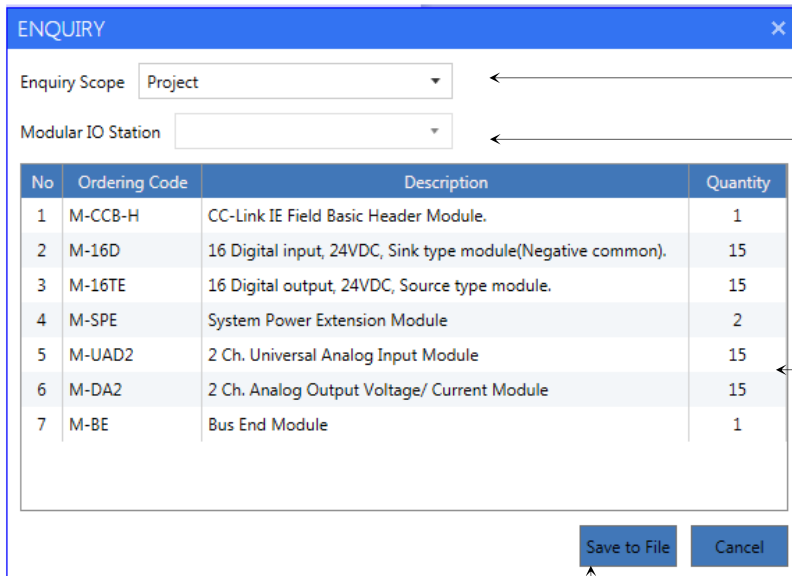

No	Ordering Code	Description	Quantity
1	M-CCB-H	CC-Link IE Field Basic Header Module.	1
2	M-16D	16 Digital input, 24VDC, Sink type module(Negative common).	15
3	M-16TE	16 Digital output, 24VDC, Source type module.	15
4	M-SPE	System Power Extension Module	2
5	M-UAD2	2 Ch. Universal Analog Input Module	15
6	M-DA2	2 Ch. Analog Output Voltage/ Current Module	15
7	M-BE	Bus End Module	1

User can select enquiry scope as either **Project** or **Modular IO Station**.

This field is active when user chooses "Enquiry Scope" parameter is set as **Modular IO Station**.

User can select Modular IO station (Header module) from the list of configured stations.

Tool generates list of modules as per configuration.

User can save enquiry document on local drive in .csv format.

2. Select Enquiry scope as Project or Modular IO Station.
 - Enquiry of all the Modular IO stations is generated if option selected is Project.
 - Enquiry of selected single Modular IO Station is generated if option selected is Modular IO Station.
3. Click on "Save to file" button to save enquiry as **<Project Name>_Enquiry.csv** on local drive.

5 Header Modules

[M-CCB-H \[CC Link IE Field Basic Header Module\]](#)

[M-MT-H \[Modbus TCP Header Module\]](#)

[M-EIP-H \[Ethernet/ IP Header Module\]](#)

[M-CCIEF-H \[CC Link IE Field Header Module\]](#)

[M-CCIEF-H \[CC Link IE TSN Header Module\]](#)

[Configuration Transfer with SDHC Memory Card](#)

5.1 M-CCB-H

[CC Link IE Field Basic Header Module]

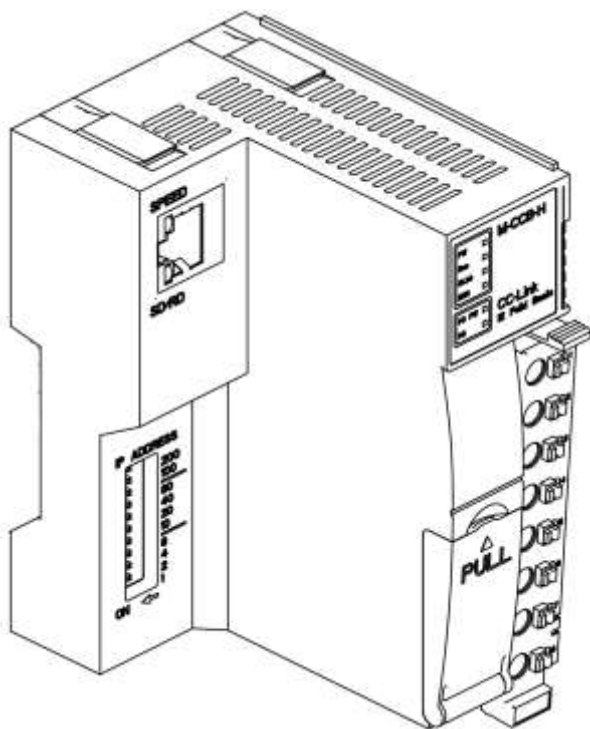

[Module Overview](#)

[Part Names](#)

[Specifications](#)

[Wiring: Module Supply](#)

[LED Indications](#)

[Setting of Station IP Address](#)

[Memory Mapping](#)

[Parameters](#)

[IO Data](#)

[Header Diagnostics](#)

[Slave Station Diagnostics Information](#)

Module Overview

M-CCB-H Header module is a slave station in a CC-Link IE Field Basic network.

The figure below provides overall system configuration.

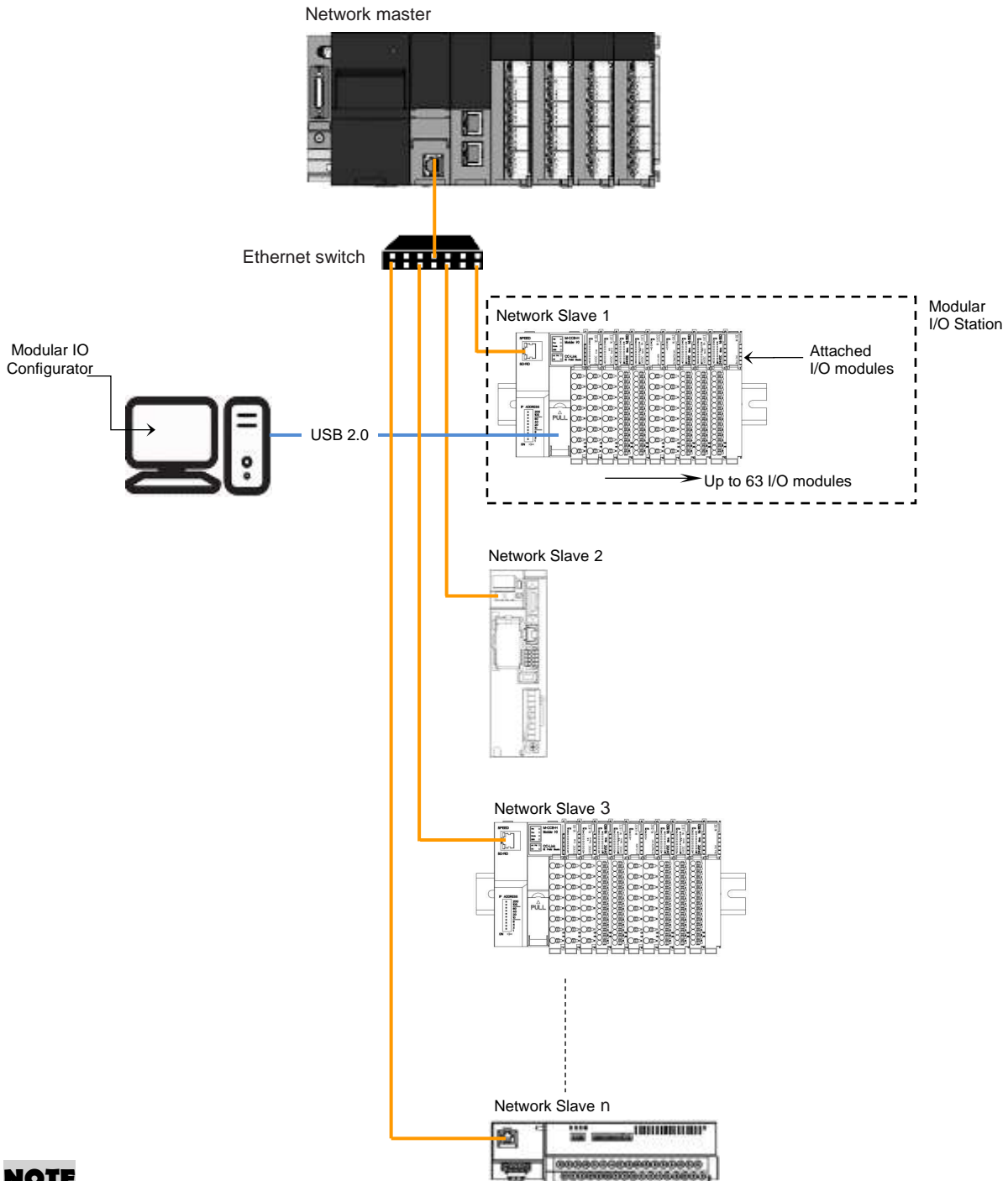

NOTE

- Refer CC-Link IE Field Network Basic [Manual Number: SH (NA)-081684ENG-D] and onwards for more information.
- Refer “Quick Start Guide Interfacing Modular IO Header M-CCB-H with Mitsubishi PLCs on CC-Link IE Field Basic Network.doc” to establish communication with Mitsubishi PLCs (iQ-R, iQ-F, Q and L series).

Part Names

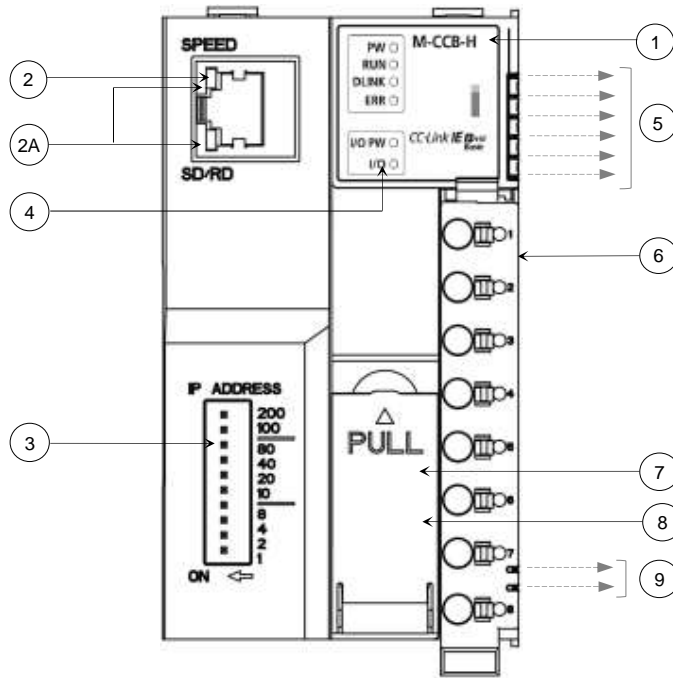

No.	Name	Description
1	M-CCB-H	Module ordering code
2	Ethernet Port [RJ45]	CC-Link IE Field Basic communication port
2A	LED Indications on Ethernet port	SPEED: 1 Green LED for link status SD/RD: 1 Green LED for data transmission status
3	Settings for Station IP Address	Last octet of IP address is set by DIP switch
4	Module LED Indication	PW: 1 Green LED for power status of module. RUN: 1 Green LED for operation status of module. D LINK: 1 Green LED to display data link status of module. ERR: 1 Red LED to display error status of module. I/O PW: 1 Green LED for field power status. I/O: 1 Bi-colour LED for module status.
5	System Power Supply Interface	6 Outgoing pins for System power supply interface
6	Terminal Block	8-point removable push type
7	SD Card Interface	Micro SD (for configuration transfer)
8	USB Interface	USB 2.0
9	Field Power Supply Interface	2 Outgoing pins for Field power supply interface

Specifications

The table below provides technical specifications of **M-CCB-H**.

Specification		Description				
Module Ordering Code		M-CCB-H				
System Power Supply	Input voltage	24 VDC (11 to 28.8 VDC, ripple included), 22 Watt				
	Inrush current	20 A for 20 µsec duration				
	Protection	Reverse polarity protection				
	Output voltage	5 VDC				
	Output current for IO modules	2 A				
	Isolation	Non-isolated				
Field Power Supply	Voltage	24 VDC				
	Current	10 A				
External Connections	Network communication	RJ45 female				
	Input power supply (System power supply and Field power supply)	8 Point terminal block				
	Output System power supply	6-Pins				
	Output Field power supply	2-Pins				
	Configuration port	USB 2.0				
Fieldbus Support		CC-Link IE Field Basic				
Station Type		Slave station				
Number of Occupied Stations		1-4 stations (user configurable)				
Number of IO Modules		63 maximum (including system modules ^[1])				
IO Data Size		Depends on number of stations occupied				
		No. of occupied stations	RX	RY	RWr	RWw
		1	64 bits	64 bits	32 words	32 words
		2	128 bits	128 bits	64 words	64 words
		3	192 bits	192 bits	96 words	96 words
		4	256 bits	256 bits	128 words	128 words
Communication Protocol		UDP				
Port Numbers		No. 61450 (Cyclic data)				
		No. 61451 (Node Search and IP Address Set dedicated for CC-Link IE Field Basic Network)				
IP Address		IPv4 range: 0.0.0.1 to 223.255.255.254 (Default 192.168.3.0)				
Subnet mask		Default: 255.255.255.0 Changes as per IP address class.				
Physical Layer		10/100BASE-T				
Cable for Fieldbus Communication		Ethernet standard compliant products cable Cat5e or higher, shielded twisted pair cable				
Maximum Cable Distance		100 meters				

Specification	Description
Network Topology	Star
Recommended Wire Specifications	0.5 sq. mm to 2.0 sq. mm (AWG 20 to 14), Solid wire or Stranded (flexible) wire with lugs
Module Dimensions (H x W x D) in mm	105 x 60 x 92

NOTE

*1 Digital and analog IO modules are intelligent modules and provide IO data and diagnostics to Header module. System modules are passive modules. So, Header module does not provide any information about system modules.

Header module cannot detect presence of System modules in a modular IO station. So, System modules do not appear in the list after scan.

Wiring: Module Supply

The figure shows Header module front alongwith system power supply connections and field power supply connections. Wiring description is provided on right side wall of the module.

For common wiring recommendations, refer section [Wiring](#).

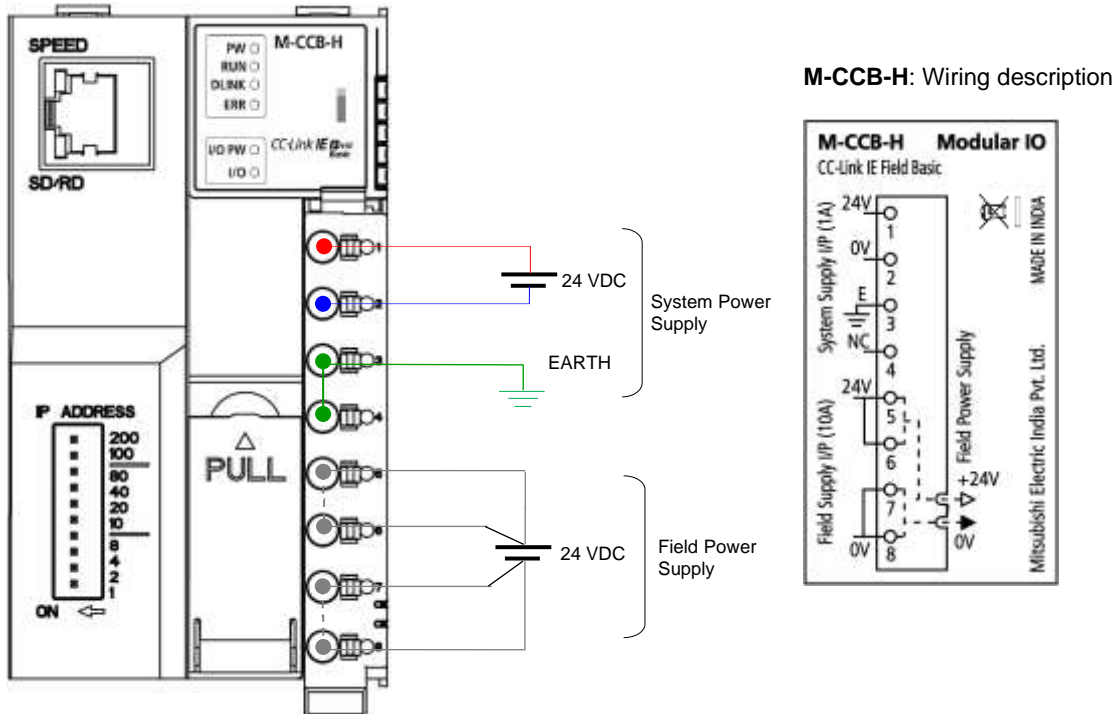

Connect +24 VDC system power supply between first two terminals (i.e. terminal 1 and 2).

Connect terminals 3/ 4 to clean EARTH directly.

Connect +24 VDC field power supply to terminal numbers 5 and 6.

Connect field power supply ground to terminal numbers 7 and 8.

NOTE

The current carrying capacity of each terminal of terminal block is 5 A max. Field power supply interface between modules has current carrying capacity of 10 A.

So, it is necessary to connect 2 wires from source of field power supply to utilize maximum capacity of 10 A. Field power supply connected to terminal block is directly carried to field power supply pins for interfacing with IO modules.

Ensure that EARTH cable is thick and short as far as possible to provide a low impedance path.

LED Indications

This section provides the meaning of LED indications available on Header module.

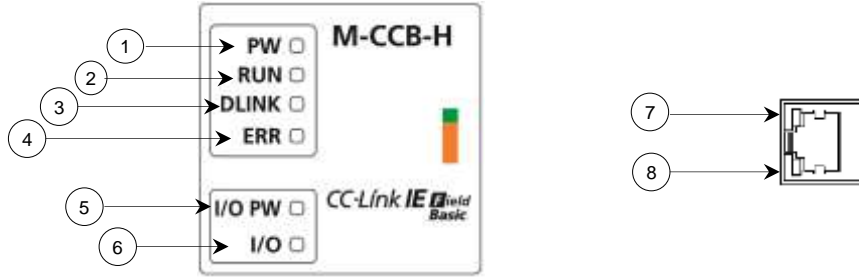

No.	*LED	Colour	Status	Description
1	PW	Green	ON	System power to Header module is ON
			OFF	System power to Header module is OFF
2	RUN	Green	ON	Header module functioning normal. No hardware error detected.
			OFF	Hardware error detected.
			Blinking	If SD card is detected in Header slot at power ON, <ul style="list-style-type: none"> Configuration download or upload to/from SD card is in progress.
3	D LINK	Green	ON	Cyclic transmission is ON.
			Blinking	Cyclic transmission stopped due one of the conditions occurred. <ul style="list-style-type: none"> Number of occupied station mismatch. Station not configured in network master. Another station with same IP address detected on network. Header configuration download is in progress.
			OFF	Data link not established.
4	ERR	Red	ON	Fatal station error occurred*.
			Blinking	Non-fatal station error occurred*.
			OFF	No error
5	I/O PW	Green	ON	Field power to Header module is ON
			OFF	Field power to Header module is OFF

6	I/O	Bi-colour	None	Header module is powered OFF or Hardware failure error detected on header module.	
			Blue Green	ON	Header module is powered ON and communicating with IO module and no error is present.
				Single Flash	Header module is powered ON and ready for communication with IO modules. No IO module detected.
			Red	ON	One of the following conditions occurred. <ul style="list-style-type: none"> Invalid configuration detected. No communication due to backplane bus fault. Header configuration download (using either USB interface or SD card interface) is in progress
				Single Flash	IO module mismatch detected for one or more IO slots.
				Double Flash	Communication error observed for one or more IO modules.
				Triple Flash	Fatal error (Except IO Module mismatch or communication error) is observed for one or more IO modules, OR IO module related error is observed for one or more modules. [This includes sensor wire break, no 24V detected by IO module etc.]
Yellow	ON	Output test mode is ON.			
8	SPEED	Green	ON	Link up (100 Mbps)	
			OFF	Link down or link up (10 Mbps)	
7	SD/RD	Green	ON	Data transmission or reception is in progress on Ethernet port.	
			OFF	No data transmission or reception.	

*For more details of LED indication states and flashing rates, refer section [Troubleshooting >> LED indications: States and flashing rates](#) in this manual.

Setting of Station IP Address

This section provides information about setting of IP address on Header module.

The first three octets of IP address are generated by network master station and the fourth octet is set using DIP switches as shown below.

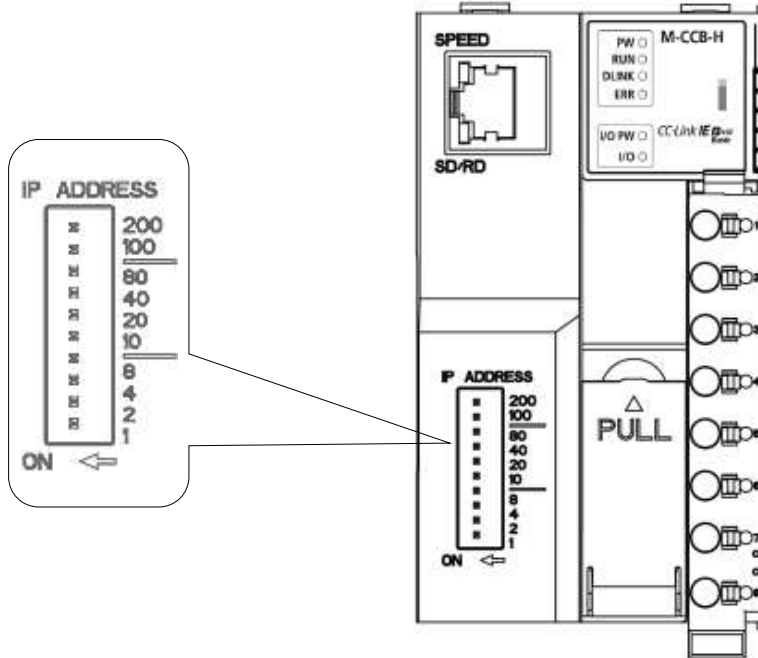

Example below shows DIP switch setting for value of 235.

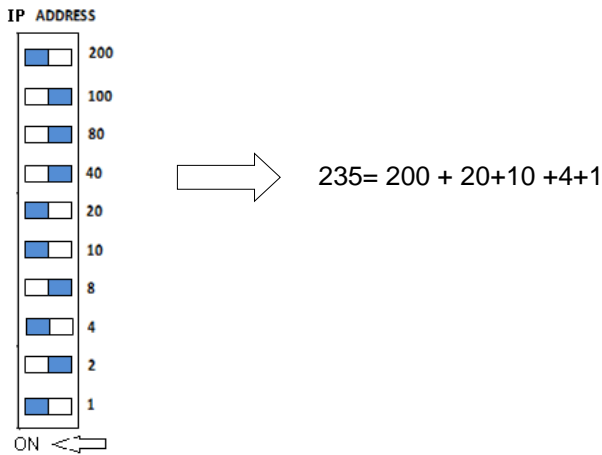

NOTE

If DIP switch setting is 0 (all switches set to OFF), then module switches to default IP address (192.168.3.100) and subnet mask (255.255.255.0).

Later on, user can modify default IP address and subnet mask using engineering software, after automatic detection of network devices.

Memory mapping

Local memory is mapped to CC-Link IE Field Basic remote IO and remote registers as shown below.

Memory Area	Local Address	Access	CC Link IE Field Basic master
Input bit	IX	Read	RX
Input word	IW	Read	RWr
Output bit	QX	Write	RY
Output word	QW	Write	RWw
Status byte	SB	Read	RWr

NOTE

SB memory is shared with network master if "Share SB to RWr" parameter is set as Enable'.

Both IW and SB memories are mapped to RWr memory. IW memory is mapped first, followed by SB memory.

The number of occupied stations configured decides size of memory to be shared with master during cyclic transmission. The table below shows the size of link device memory consumed depending on number of occupied stations.

No. of Occupied Stations	RX	RY	RWr	RWw
1	64 bits	64 bits	32 words	32 words
2	128 bits	128 bits	64 words	64 words
3	192 bits	192 bits	96 words	96 words
4	256 bits	256 bits	128 words	128 words

NOTE

CC-Link IE Field Basic slave device consumes complete link device memory as per number of occupied stations irrespective of usage e.g. even though slave device is 16 Pt. digital input module, it consumes RX (64 bits), RY (64 bits), RWr (32 words) and RWw (32 words). Out of this memory, RX (16-bits) is useful, and the rest of the memory is consumed but unused.

Parameters

Configure modular IO station with header as explained in section '[Configure Modular IO station with Header](#)'.

Set the following parameters using Modular IO Configurator.

Parameter Name	Project Value	Comment
Number of stations occupied	1 [Default]	Defines number of stations occupied.
	2	
	3	
	4	
Share diagnostics	Enable [Default]	Enables diagnostic data (SB) updation.
	Disable	
Action on fatal error	Stop N/W Communication	Defines action on fatal error to any slot including header. Stop or continue communication with N/W master.
	Continue N/W Communication	
Share SB to RWr	Enable	Enables diagnostic data (SB) aharing with N/W master
	Disable [Default]	
Output hold/ clear	Hold	Defines output state of IO modules when disconnected from N/W or master CPU is not in RUN mode.
	Clear	

Header diagnostic data is available in Status Byte (SB) memory, if parameter "Share diagnostics" is set to **Enable**.

IO Data

User can monitor following Header diagnostics in SB memory.

Diagnostic Summary	Data Type	Local Address*	Bit Status	Description
Hardware failure	BOOL	SB 0.0	TRUE	Becomes TRUE, if hardware error of Header module occurs.
			FALSE	
Configuration error	BOOL	SB 0.1	TRUE	Becomes TRUE, if invalid configuration data is downloaded in Header module.
			FALSE	
IO module mismatch error	BOOL	SB 0.2	TRUE	Becomes TRUE, if IO module configured in slot is different than the physically present IO module.
			FALSE	
IO module COM error	BOOL	SB 0.3	TRUE	Becomes TRUE, if data exchange between Header and one or more IO modules is stopped after successful data exchange.
			FALSE	
Reserved	BOOL	SB 0.4	--	--
Reserved	BOOL	SB 0.5	--	--
Fatal error in one or more slots	BOOL	SB 0.6	TRUE	Becomes TRUE, if fatal error occurs in one or more IO slots.
			FALSE	
Non-fatal error in one or more slots	BOOL	SB 0.7	TRUE	Becomes TRUE, if non-fatal error occurs in one or more IO slots.
			FALSE	
Reserved	BOOL	SB 1.0	--	--
Additional IO modules detected	BOOL	SB 1.1	TRUE	Becomes TRUE, if Header module detects additional IO modules (other than configured one) at modular IO station.
			FALSE	
Reserved	BOOL	SB 1.2	--	--

User can monitor slot status.

Slot Status	Data Type	Local Address*	Bit Status	Description
Slot status 0..7				
Slot 0	BOOL	SB 2.0	TRUE	Module is configured in slot 0 and healthy.
			FALSE	Module in slot 0 has error or module is not configured in slot 0.
⋮	⋮	⋮	⋮	
Slot 7	BOOL	SB 2.7	TRUE	Module is configured in slot 7 and healthy.
			FALSE	Module in slot 7 has error or module is not configured in slot 7.
Slot status 8..15				
Slot 8	BOOL	SB 3.0	TRUE	Module is configured in slot 8 and healthy.
			FALSE	Module in slot 8 has error or module is not configured in slot 8.
⋮	⋮	⋮	⋮	
Slot 15	BOOL	SB 3.7	TRUE	Module is configured in slot 15 and healthy.

			FALSE	Module in slot 15 has error or module is not configured in slot 15.
⋮	⋮	⋮	⋮	
⋮	⋮	⋮	⋮	
Slot status 56..63				
Slot 56	BOOL	SB 9.0	TRUE	Module is configured in slot 56 and healthy.
			FALSE	Module in slot 56 has error or module is not configured in slot 56.
⋮	⋮	⋮	⋮	
Slot 63	BOOL	SB 9.7	TRUE	Module is configured in slot 63 and healthy.
			FALSE	Module in slot 63 has error or module is not configured in slot 63.

Also, refer section '[List of Station Error Codes](#)' for details of Error codes displayed in Modular IO configurator tool.

Header diagnostics

Detailed diagnostics of header module (Header diagnostics) can be monitored in Modular IO Configurator tool. Refer section '[Header diagnostics and slot diagnostics](#)' for more details.

For M-CCB-H, the following status and diagnostic information is available.

Diagnosics	Description
Identification	
Vendor code	Vendor code of manufacturer. 00: Mitsubishi Electric India.
Ordering code	Ordering code of header module. M-CCB-H : For CC-Link IE Field Basic Header module
Version Info	
Device version	Device version of header module.
Hardware version	Hardware version of header module.
Firmware version	Firmware version of header module.
Backplane bus version	Backplane bus version of header module.
Hardware	
EEPROM checksum	EEPROM checksum.
Self-diagnostic test	Bitwise status of self-tests at start up.
ROM test	Result of ROM test (0: No error, 1: Error)
RAM test	Result of RAM test (0: No error, 1: Error)
Reserved	--
EEPROM test	Result of EEPROM test (0: No error, 1: Error)
MAC ID test	Result of MAC ID test (0: No error, 1: Error)
DIP switch setting	DIP switch setting to set IP address of Header module
Switch 1	Status of DIP switch 1: ON, 0 OFF
Switch 2	Status of DIP switch 1: ON, 0 OFF
⋮	⋮
Switch 10	Status of DIP switch 1: ON, 0 OFF
IP setting	
IP address	Header IP address.
Subnet mask	Subnet mask.
MAC ID	Header MAC ID.
Memory size	
IX	Configured size of bit input image (IX) No. of bytes
IW	Configured size of word input image (IW).No. of bytes
QX	Configured size of bit output image (QX). No. of bytes
QW	Configured size of word output image (QW) No. of bytes
SB	Configured size of diagnostic (SB) image No. of bytes
Current	Header scan time.
Maximum	Maximum header scan time.
Minimum	Minimum header scan time.
Diagnostics summary	

No. of configured slots	Number of configured slots.
No. of detected slots	Number of detected slots.
Status	Bitwise status of header module.
Hardware failure	Hardware failure detected. Check self-diagnostic test results.
Configuration error	Invalid configuration detected for header.
IO module mismatch	Module absent or different module present in one or more slots.
IO module COM error	Module communication error detected during runtime.
Reserved	--
Reserved	--
Slot fatal error	Fatal error detected for one or more slots.
Slot non-fatal error	Non-fatal error detected for one or more slots.
Reserved	--
Additional IO modules detected	Number of IO modules detected are more than number of IO modules configured.
Slots 0-15	
Detected	Bitwise module detection status.
Healthy	Bitwise module health status.
IO error	Bitwise status of module mismatch or absent.
COM error	Bitwise status of COM error after power ON
Fatal error	Bitwise (slotwise) status of module fatal error.
Non-fatal error	Bitwise status of module non-fatal error
Slots 48-63	
Detected	Bitwise module detection status.
Healthy	Bitwise module health status.
IO error	Bitwise status of module mismatch or absent.
COM error	Bitwise status of COM error after power ON
Fatal error	Bitwise (slotwise) status of module fatal error.
Non-fatal error	Bitwise status of module non-fatal error
CC-Link IE Field Basic diagnostics	
CC-Link IE Field diagnostics	Bitwise CC-Link IE Field Basic diagnostics
Cyclic data transmission ON	1: Cyclic data transmission ON, 0: Cyclic data transmission OFF
Invalid station ID	1: Invalid station ID, 0: Valid station ID
Duplicate station ID	1: Duplicate station ID detected, 0: No duplicate station ID detected
Slave disconnects due to time-out	1: Slave disconnects due to timeout error, 0: No error
Slave station disconnection request issued	1: Slave station disconnection request issued, 0: No error
Number of occupied station mismatch	1: Number of occupied station mismatch, 0: No error
Control master detected	1: Control master detected, 0: No control master detected.
IP address setting switch changed	1: IP address setting switch changed while module is powered ON, 0: No error.
PHY link down	1: PHY link down detected, 0: No error.
Time between cyclic transmission requests (msec)	Time between last two transmission requests received from master (msec).
Maximum time between cyclic transmission requests (msec)	Maximum time between cyclic transmission requests (msec).
Minimum time between cyclic transmission requests (msec)	Minimum time between cyclic transmission requests (ms).

Time since last cyclic transmission requests (msec)	Time since last cyclic transmission request (msec).
No. of cyclic transmission requests received	Number of cyclic transmission requests received.
No. of cyclic transmission responses sent	Number of cyclic transmission responses sent.
No. of receive frame error	Number of receive frame errors.

Slave station diagnostic information

The list of slave station diagnosis information that is available in the buffer memory or the special register of the master station is explained in the table below.

Master Station Memory			Description	Value
iQ-R CPU	QnUDV/L CPU	FX5U CPU		
Un\G1068	SD1758	SD11142	Vender code	2071H
Un\G1069	SD1759	SD11143	Reserved	
Un\G1070	SD1760	SD11144	Model code (L)	3E81H
Un\G1071	SD1761	SD11145	Model code (H)	0H
Un\G1072	SD1762	SD11146	Device version	0H
Un\G1073	SD1763	SD11147	Reserved	
Un\G1074	SD1764	SD11148	Host station unit information	Bit 0 is set in case of fatal error Bit 1 to 15: Reserved
Un\G1075	SD1765	SD11149	Error code	Refer table below
Un\G1076	SD1766	SD11150	Host station administrative information (L)	Reserved
Un\G1077	SD1767	SD11151	Host station administrative information (H)	

The table below provides list of error codes provided in slave station diagnostic information.

Error Code	Classification	Error Name	Probable Cause	Corrective Action
0010H	Fatal	Hardware failure	All modules	Module hardware error
0101H	Non-Fatal	IP address switch Setting out of range error	DIP Switch Setting	Set the IP address setting switch in the range of from1 to 254 and power recycle of the header
0201H	Non-Fatal	IP address setting switch is changed	Reserved	Set the switch again to the switch state at the time when module power supply is turned ON.
01FFH	Fatal	Fatal error detected at modular IO station	One or more slots on modular I/O station are facing a fatal error issue.	Resolve the issue at modular IO station and recycle power.
02FFH	Non-Fatal	Non-Fatal error detected at modular IO station	One or more slots on modular IO station are facing fatal error	Ensure the wiring of Modular IO station

5.2 M-MT-H

[Modbus TCP Header Module]

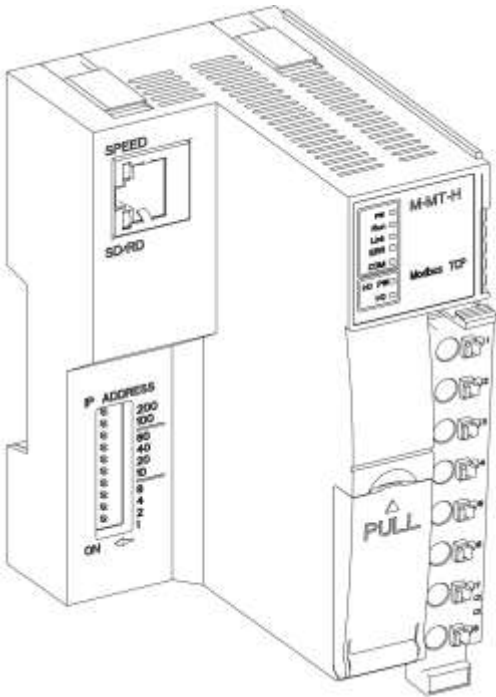

[Module Overview](#)

[Part Names](#)

[Specifications](#)

[Wiring: Module Supply](#)

[LED Indications](#)

[Setting of Station IP Address](#)

[Memory Mapping](#)

[Parameters](#)

[IO Data](#)

[Header Diagnostics](#)

Module Overview

M-MT-H Header module is a Modbus TCP server in a Modbus TCP network. It allows connection of 1 Modbus TCP client at a time.

Part Names

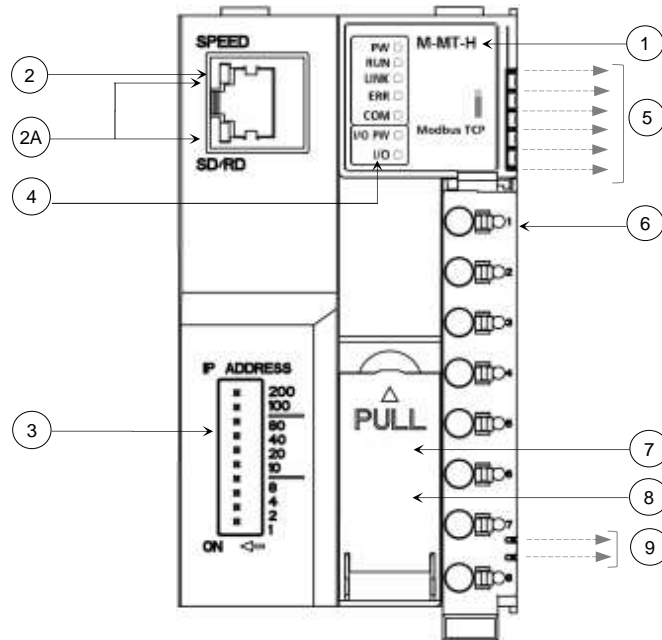

No.	Name	Description
1	M-MT-H	Module ordering code
2	Ethernet Port [RJ45]	Field bus communication port
2A	LED Indications on Ethernet port	SD/ RD: 1 Green LED for data transmission status SPEED: 1 Green LED for link status
3	Settings for Station IP Address	Last octet of station IP address is set by DIP switch
4	Module LED Indication	PW: 1 Green LED for power status of module. RUN: 1 Green LED for operation status of module. D LINK: 1 Green LED to display data link status of module. ERR: 1 Red LED to display error status of module. I/O PW: 1 Green LED for field power status. I/O: 1 Bi-colour LED for module status.
5	System Power Supply Interface	6 Outgoing pins for System power supply interface
6	Terminal Block	16-point removable push type
7	SD Card Interface	Micro SD (for configuration transfer)
8	USB Interface	USB 2.0
9	Field Power Supply Interface	2 Outgoing pins for Field power supply interface

Specifications

The table below provides technical specifications of **M-MT-H**.

Specification		Description
Module Ordering Code		M-MT-H
System Power Supply	Input voltage	24 VDC (11 to 28.8 VDC, ripple included), 22 Watt
	Inrush current	20 A for 20 µsecs duration
	Output voltage	5 VDC
	Output current for IO modules	2 A
	Protection	Reverse polarity protection
	Isolation	Non-isolated
Field Power Supply	Voltage	24 VDC (18 to 30 VDC, ripple included)
	Current	10 A
External Connections	Network communication	RJ45 female
	Input power supply (System power supply and Field power supply)	8 Point terminal block
	Output System power supply	6-Pins
	Output Field power supply	2-Pins
	Configuration port	USB 2.0
Fieldbus Support		Modbus TCP Server; 1 client connection
Baud Rate		10/100 Mbps
IO Data Size		1024 digital inputs 1024 digital output 256 analog inputs 256 analog outputs 512 bytes status memory
Communication Protocol		TCP
Port Number		502
IP Address		IPv4 range: 0.0.0.1 to 223.255.255.254 (Default 192.168.3.100)
Subnet mask		Default: 255.255.255.0
Cable for Fieldbus Communication		Ethernet standard compliant products cable Category 5 or higher (STP cable)
Maximum Cable Distance		100 meters
Network Topology		Star
Number of IO Modules		63 maximum (including system modules ^{*1})
Terminal Block (Removable push type)		8 Point
Recommended Wire Specifications		0.5 sq. mm to 2.0 sq. mm (AWG 20 to 14), Solid wire or Stranded (flexible) wire with lugs
Module Dimensions (H x W x D) in mm		105 x 60 x 92

NOTE

*1 Digital and analog IO modules are intelligent modules and provide IO data and diagnostics to Header module. System modules are passive modules. So, Header module does not provide any information about system modules. Header module cannot detect presence of System modules in a modular IO station. So, System modules do not appear in the list after scan.

Wiring: Module Supply

The figure shows Header module front alongwith system power supply connections and field power supply connections. Wiring description is provided on right side wall of the module.

For common wiring recommendations, refer section [Wiring](#).

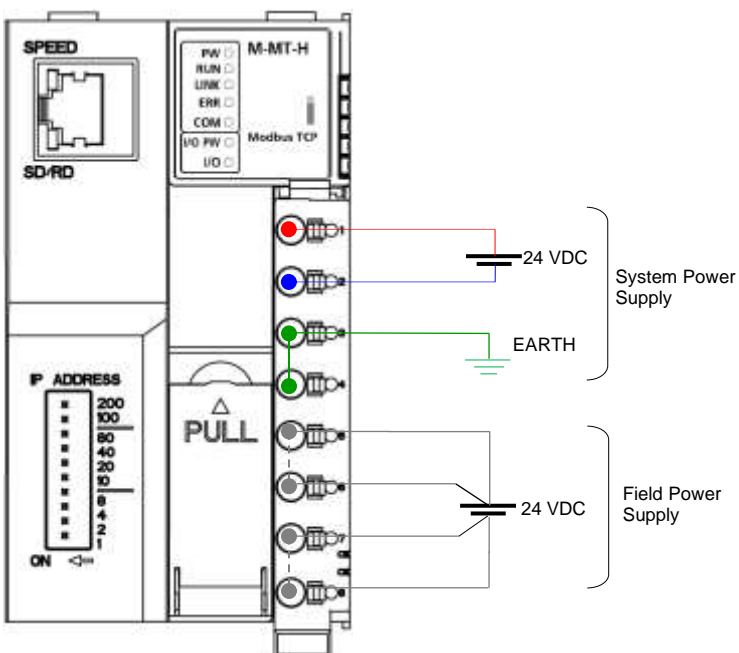
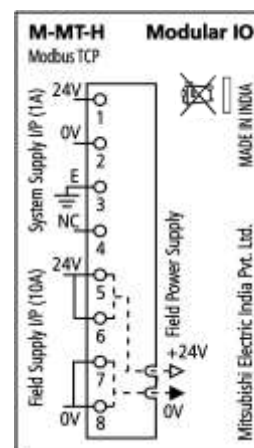
**M-MT-H: Wiring description**

Connect +24 VDC system power supply between first two terminals (i.e. terminal 1 and 2).

Connect terminals 3/ 4 to clean EARTH directly.

Connect +24 VDC field power supply to terminal numbers 5 and 6.

Connect field power supply ground to terminal numbers 7 and 8.

NOTE

The current carrying capacity of each terminal is 5A max. So, it is necessary to connect 2 wires from source of field power supply to utilize maximum capacity of 10 A of Field power supply interface between modules.

Field power supply connected to terminal block is directly carried to field power supply pins for interfacing with IO modules.

Ensure that EARTH cable is thick and short as far as possible to provide low impedance path.

LED Indications

This section provides the meaning of LED indications available on Header module.

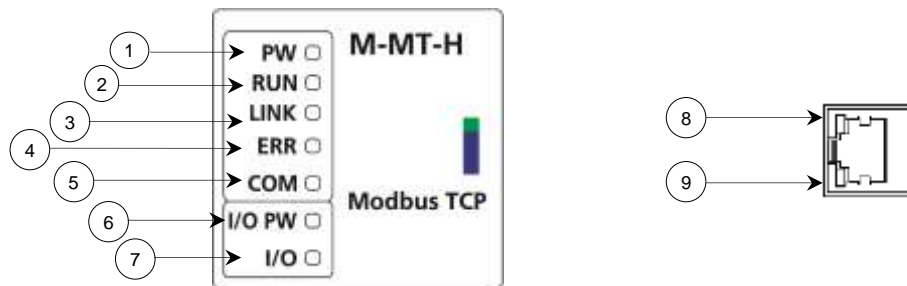

No.	LED	Colour	Status	Description	
1	PW	Green	ON	System power to Header module is ON	
			OFF	System power to Header module is OFF	
2	RUN	Green	ON	Header module functioning normal. No hardware error detected.	
			OFF	Hardware error detected	
			Blinking	If SD card is detected in Header slot at power ON, <ul style="list-style-type: none"> Configuration download or upload to/from SD card is in progress. 	
3	LINK	Green	ON	Modbus TCP port is open	
			OFF	Modbus TCP port is close	
4	ERR	Red	ON	Fatal station error occurred*.	
			Blinking	Non-fatal station error occurred*.	
			OFF	No error.	
5	COM	Green	ON	Valid Modbus query is received, and response sent.	
6	I/O PW	Green	ON	Field power to Header module is ON	
			OFF	Field power to Header module is OFF	
7	I/O	Bi-colour	None	Header module is powered OFF or Hardware failure error detected on header module.	
			Blue Green	ON	Header module is powered ON and communicating with IO module and no error is present.
				Single Flash	Header module is powered ON and ready for communication with IO modules. No IO module detected.
			Red	ON	One of the following conditions occurred. <ul style="list-style-type: none"> Invalid configuration detected. No communication due to backplane bus fault. Header configuration download (using either USB interface or SD card interface) is in progress.
				Single Flash	IO module mismatch detected for one or more IO slots.
				Double Flash	Communication error observed for one or more IO modules.
				Triple Flash	Fatal error (Except IO Module mismatch or communication error) is observed for one or more IO modules, OR IO module related error is observed for one or more modules. [This includes sensor wire break, no 24V detected by IO module etc.]
Yellow	ON	Output test mode is ON.			

8	SPEED	Green	ON	Link up (100 Mbps)
			OFF	Link down or link up (10 Mbps)
9	SD/RD	Green	ON	Data transmission or reception is in progress on Ethernet port.
			OFF	No data transmission or reception.

*For more details of LED indication states and flashing rates, refer section [Troubleshooting >> LED indications: States and flashing rates](#) in this manual.

Setting of Station IP Address

This section provides information about setting of station IP address on Header module.

The first three octets of IP address are configured using Modular IO Configuration Tool and the fourth octet is set using DIP switches as shown below.

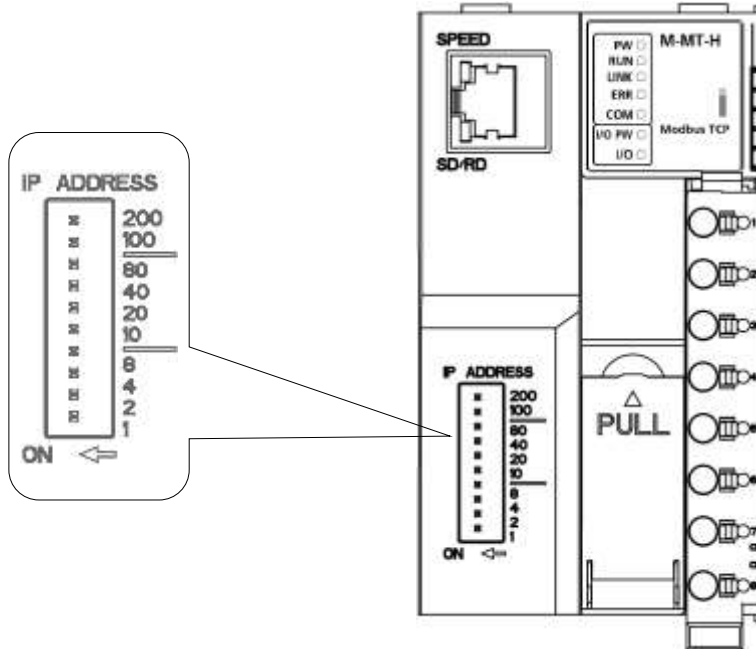

Example below shows DIP switch setting for value of 235.

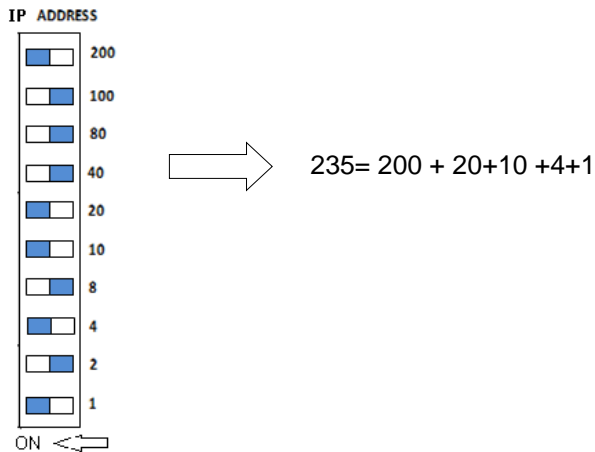

Memory Mapping

Local memory is mapped to Modbus memory as shown below.

Memory Area	Local address	Access	Addressing Method	Modbus Address	Function Code
Input Bit	IX0 to IX127	Read	WORD	0000 to 0063	FC03, FC04, FC23
			BIT	0000 to 1023	FC01, FC02
Input Word	IW0 to IW255	Read	WORD	1000 to 1255	FC03, FC04, FC23
Output Bit	QX0 to QX127	Read /Write	WORD	2000 to 2063	FC03, FC04, FC06, FC16, FC23
			BIT	2000 to 3023	FC01, FC02, FC05, FC15
Output word	QW0 to QW255	Read /Write	WORD	3000 to 3255	FC03, FC04, FC06, FC16, FC23
Status Memory	SB0 to SB511	Read	WORD	4000 to 4255	FC03, FC04, FC23
Illegal Address Ranges	Not applicable	NA	WORD	64 -999	All
	Not applicable	NA	WORD	1256 - 1999	
	Not applicable	NA	WORD	2064 - 2999	
	Not applicable	NA	WORD	3256 - 3999	
	Not applicable	NA	WORD	4256 - 65535	
	Not applicable	NA	BIT	1024 - 1999	
	Not applicable	NA	BIT	3024 - 65535	
	IX0 to IX127	Read	BIT	0000 to 1023	
	IX0 to IX127	Read	WORD	0000 to 0063	FC06, FC16
	IW0 to IW255	Read	WORD	1000 to 1255	FC06, FC16
	SB0 to SB511	Read	WORD	4000 to 4255	FC06, FC16

Following Modbus function codes are supported:

Function name	Function code	Descriptions
Read coil status	1	Read output bit
Read input status	2	Read input bit
Read holding register	3	Read output word
Read input register	4	Read input word
Write/force single coil	5	Write single output bit
Write/Preset single register	6	Write single output register
Write/Force multiple coils	15	Write number of output bits
Preset multiple register	16	Write number of output registers
Read/ write registers	23	Read a number of output words /Write a number of output words

The table below provides a list of Modbus exception codes supported.

Exception Name	Exception Code	Description
Illegal Function	1	Function code received in the query is not recognized or allowed by slave or invalid MBAP
Illegal Data Address	2	The data address received in the query is not an allowable address for the slave. More specifically, the combination of reference number and transfer length is invalid.
Illegal Data Value	3	Value is not accepted by slave. <ul style="list-style-type: none"> - Invalid data length requested. - Invalid output value, in case of FC05
Slave Device Failure	4	Fatal error occurred while the slave was attempting to perform the requested action. <ul style="list-style-type: none"> - IP address out of range - IO module error (depend on parameter setting "Action on fatal error")
Slave Device Busy	6	Slave is engaged in processing a long-duration command like configuration download, the request message processing cannot be executed

Parameters

Configure modular IO station with header as explained in section '[Configure Modular IO station with Header](#)'.

Set the following parameters using Modular IO Configurator.

Parameter Name	Project Value	Comment
IP Address	192.168.3.100 [Default]	Header IP address
Subnet mask	255.255.255.0	Subnet mask
Action on fatal error	Stop N/W Communication	Defines action on fatal error to any slot including header. Stop or continue communication with N/W master.
	Continue N/W Communication [Default]	
Modbus watchdog time (msec)	1000 [Default]	Communication watchdog time in msec
Output hold/ clear	Hold	Defines output state of IO modules when disconnected from network or master CPU is not in RUN mode.
	Clear [Default]	

Header diagnostic data is available in Status Byte (SB) memory if parameter "Share diagnostics" is set to **Enable**.

IO Data

User can monitor following Header diagnostics in SB memory.

Diagnostic summary	Data Type	Local Address*	Bit Status	Description
Hardware failure	BOOL	SB 0.0	TRUE	Becomes TRUE, if hardware error on Header module occurs.
			FALSE	
Configuration error	BOOL	SB 0.1	TRUE	Becomes TRUE, if invalid configuration data is downloaded in Header module.
			FALSE	
IO module mismatch error	BOOL	SB 0.2	TRUE	Becomes TRUE, if IO module configured in slot is different than than the physically present IO module.
			FALSE	
IO module COM error	BOOL	SB 0.3	TRUE	Becomes TRUE, if data exchange between Header and one or more IO modules is stopped after successful data exchange.
			FALSE	
Reserved	BOOL	SB 0.4	--	--
Reserved	BOOL	SB 0.5	--	--
Fatal error in one or more slots	BOOL	SB 0.6	TRUE	Becomes TRUE, if fatal error occurs in one or more IO slots.
			FALSE	
Non-fatal error in one or more slots	BOOL	SB 0.7	TRUE	Becomes TRUE, if non-fatal error occurs in one or more IO slots.
			FALSE	
Reserved	BOOL	SB 1.0	--	--
Additional IO modules detected	BOOL	SB 1.1	TRUE	Becomes TRUE, if Header module detects additional IO modules (other than configured one) at modular IO station.
			FALSE	
Reserved	BOOL	SB 1.2	--	--

User can monitor slot status.

Slot status	Data Type	Local Address*	Bit Status	Description
Slot status 0..7				
Slot 0	BOOL	SB 2.0	TRUE	Module is configured and working Ok in slot 0.
			FALSE	Module is either not configured in slot 0 or having error.
Slot 7	BOOL	SB 2.7	TRUE	Module is configured and working Ok in slot 7.
			FALSE	Module is either not configured in slot 7 or having error.
Slot status 8..15				
Slot 8	BOOL	SB 3.0	TRUE	Module is configured and working Ok in slot 8.
			FALSE	Module is either not configured in slot 8 or having error.
Slot 15	BOOL	SB 3.7	TRUE	Module is configured and working Ok in slot 15.
			FALSE	Module is either not configured in slot 15 or having error.
Slot status 56..63				
Slot 56	BOOL	SB 9.0	TRUE	Module is configured and working Ok in slot 56.
			FALSE	Module is either not configured in slot 56 or having error.
Slot 63	BOOL	SB 9.7	TRUE	Module is configured and working Ok in slot 63.
			FALSE	Module is either not configured in slot 63 or having error.

Also, refer section '[List of Station Error Codes](#)' for details of Error codes displayed in Modular IO configurator tool.

Header diagnostics

Detailed diagnostic of header module (Header diagnostics) can be monitored in Modular IO Configurator tool. Refer section '[Header diagnostics and slot diagnostics](#)' for more details.

For M-MT-H, following status and diagnostic information is available

Diagnosics	Description
Identification	
Vendor code	Vendor code of manufacturer. 00: Mitsubishi Electric India.
Ordering code	Ordering code of header module. M-CCB-H : For CC-Link IE Field Basic Header module
Version Info	
Device version	Device version of header module.
Hardware version	Hardware version of header module.
Firmware version	Firmware version of header module.
Backplane bus version	Backplane bus version of header module.
Hardware	
EEPROM checksum	EEPROM checksum.
Self-diagnostic test	Bitwise status of self-tests at start up.
ROM test	Result of ROM test (0: No error, 1: Error)
RAM test	Result of RAM test (0: No error, 1: Error)
Reserved	--
EEPROM test	Result of EEPROM test (0: No error, 1: Error)
MAC ID test	Result of MAC ID test (0: No error, 1: Error)
DIP switch setting	DIP switch setting to set IP address of Header module
Switch 1	Status of DIP switch 1: ON, 0 OFF
Switch 2	Status of DIP switch 1: ON, 0 OFF
⋮	⋮
Switch 10	Status of DIP switch 1: ON, 0 OFF
IP setting	
IP address	Header IP address.
Subnet mask	Subnet mask.
MAC ID	Header MAC ID.
Memory size	
IX	Configured size of bit input image (IX) No. of bytes
IW	Configured size of word input image (IW).No. of bytes
QX	Configured size of bit output image (QX). No. of bytes
QW	Configured size of word output image (QW) No. of bytes
SB	Configured size of diagnostic (SB) image No. of bytes
Current	Header scan time.
Maximum	Maximum header scan time.
Minimum	Minimum header scan time.

Diagnostics summary	
No. of configured slots	Number of configured slots.
No. of detected slots	Number of detected slots.
Status	Bitwise status of header module.
Hardware failure	Hardware failure detected. Check self-diagnostic test results.
Configuration error	Invalid configuration detected for header.
IO module mismatch	Module absent or different module present in one or more slots.
IO module COM error	Module communication error detected during runtime.
Reserved	--
Reserved	--
Slot fatal error	Fatal error detected for one or more slots.
Slot non-fatal error	Non-fatal error detected for one or more slots.
Reserved	--
Additional IO modules detected	Number of IO modules detected are more than number of IO modules configured.
Slots 0-15	
Detected	Bitwise module detection status.
Healthy	Bitwise module health status.
IO error	Bitwise status of module mismatch or absent.
COM error	Bitwise status of COM error after power ON
Fatal error	Bitwise (slotwise) status of module fatal error.
Non-fatal error	Bitwise status of module non-fatal error
Slots 48-63	
Detected	Bitwise module detection status.
Healthy	Bitwise module health status.
IO error	Bitwise status of module mismatch or absent.
COM error	Bitwise status of COM error after power ON
Fatal error	Bitwise (slotwise) status of module fatal error.
Non-fatal error	Bitwise status of module non-fatal error
Modbus TCP diagnostics	
Modbus TCP diagnostics	Bitwise Modbus TCP diagnostics.
Modbus TCP port open	--
Invalid station ID	--
Watchdog error status	--
IP address setting switch changed	--
Link status	--
Modbus TCP/IP Active connection	Number of active connections.
Messages received from Master	No. of valid Modbus queries received from Master.
Responses sent to Master	No. of valid response sent to Master.
No. of invalid requests	No. of exception sent to Master.
No. of watchdog fault	No. of times watchdog fault occurred.
No. of disconnection requests	No. of disconnection requests received from Master

No. of broadcast messages	No. of broadcast messages received from Master
No. of message length errors	No. of message length error observed.
No. of invalid address errors	No. of invalid message addresses errors
No. of invalid protocol type errors	No. of times invalid protocol identifier received in Modbus query.
No. of invalid function code errors	No. of function code errors.
Time between two valid frames (msec)	Time between two valid frames (msec).
Maximum Time between two valid frames (msec)	Maximum Time between two valid frames (msec).
Minimum Time between two valid frames (msec)	Minimum Time between two valid frames (msec).
No. of receive frame errors	No. of receive frame errors.

Refer section [Troubleshooting](#) for station error code list and error messages.

5.3 M-EIP-H

[EtherNet/IP™ Header Module]

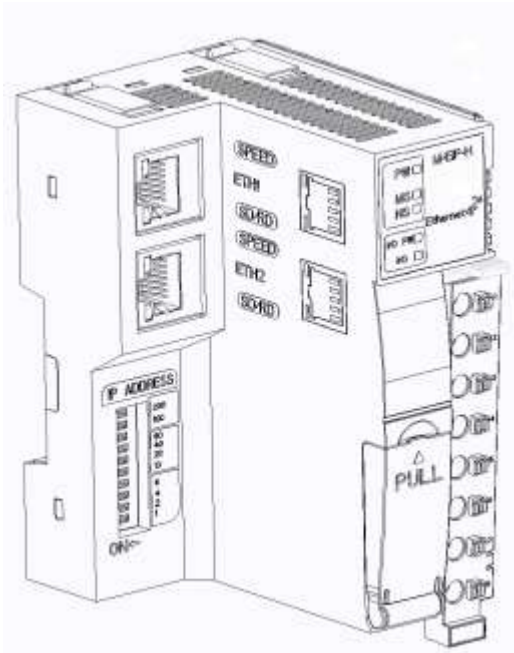

- Module Overview
- Part Names
- Specifications
- Wiring: Module Supply
- LED Indications
- Setting of Station IP Address
- Memory Mapping
- Parameters
- IO Data
- Header Diagnostics



Module Overview

Ethernet/IP™ is the Industrial Ethernet standard of ODVA (Open DeviceNet Vendor Association).

Ethernet/IP™ is based on Ethernet TCP/IP and UDP/IP – IP stands for Industrial Protocol. Essentially, the CIP (Common Industrial Protocol) used in ControlNet and DeviceNet was ported to Ethernet TCP/IP and UDP/IP.

'M-EIP-H' Header module works as communication adapter on Ethernet/IP™ network. It communicates with IO modules connected to it and exchange their IO data on Ethernet/IP™ network.

'M-EIP-H' requires configuration using 'Modular IO Configurator' before connecting on Ethernet/IP™ network. Refer section 'Modular IO Configurator' for more details.

IP address of the device can be set using parameter setting in 'Modular IO Configurator' tool and DIP switch setting. Refer section 'Setting of IP Address' for more details.

Device contains 3-port switch with DLR support. Two ports operate on RJ45 connectors and can be used for connection on Ethernet/IP™ network. The I/O stations can thus be configured with ring topology and line topology, and the classic star topology. In many applications this significantly reduces the wiring effort and the cabling costs. The maximum distance between two couplers is 100 m.

You can also refer following documentation for additional documentation.

1. N18011AAMG02 Quick Start Guide Interfacing Modular IO Header M-EIP-H with Mitsubishi Scanner on EtherNet_IP
2. N18011AAMG01 Quick Start Guide Interfacing Modular IO Header M-EIP-H with Rockwell Communication Module on EtherNet_IP
3. N18011AAMG03 M-EIP-H - Ethernet/IP™ Object Classes, Messages and Services.

EDS file of 'M-EIP-H' module is necessary to configure module in Ethernet/IP™ network. Download EDS file from link.' <https://mitsubishielectric.in/fa/fa-modular-io.html>'

Ethernet/IP™ is a trademark of ODVA, Inc.

Part Names

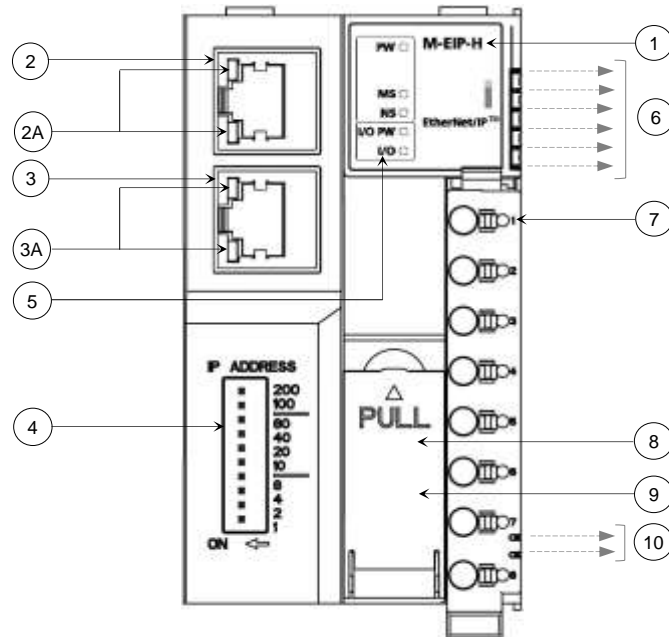

No.	Name	Description
1	M-EIP-H	Module ordering code
2	'ETH1' Ethernet Port [RJ45]	Field bus communication port
3	'ETH2' Ethernet Port [RJ45]	Field bus communication port
2A,3A	LED Indications on Ethernet ports	SD/ RD: 1 Green LED for link status SPEED: 1 LED for data transmission status
4	Settings for Station IP Address	Last octet of station IP address is set by DIP switch
5	Module LED Indication	PW: 1 Green LED for power status of module. MS: 1 Green LED for operation status of module. NS: 1 Green LED for Network status of module. I/O PW: 1 Green LED for field power status. I/O: 1 Bi-colour LED for I/O module status.
6	System Power Supply Interface	6 Outgoing pins for System power supply interface
7	Terminal Block	8-point removable push type
8	SD Card Interface	Micro SD (for configuration transfer)
9	USB Interface	USB 2.0
10	Field Power Supply Interface	2 Outgoing pins for Field power supply interface

Specifications

The table below provides technical specifications of **M-EIP-H**.

Specification		Description
Module Ordering Code		M-EIP-H
System Power Supply	Input voltage	24 VDC (11 to 28.8 VDC, ripple included), 22 Watt
	Inrush current	20 A for 20 µsecs duration
	Output voltage	5 VDC
	Output current for IO modules	2 A
	Protection	Reverse polarity protection
	Isolation	Non-isolated
Field Power Supply	Voltage	24 VDC (18 to 30 VDC, ripple included)
	Current	10 A
External Connections	Network communication	RJ45 female- 2 nos. (Configured as embedded switch)
	Input power supply (System and Field power supply)	8 Point terminal block
	Output System power supply	6-Pins
	Output Field power supply	2-Pins
	Configuration port	USB 2.0
Fieldbus Support		Ethernet/IP™
Ethernet Interfaces		2 (Layer 2 switch with DLR support)
Station Type		Communication adapter
DLR Support		Yes
IO Data Size		128 bytes: IX memory for digital input. 512 bytes: IW memory for analog input. 128 bytes: QX memory for digital output. 512 bytes: QW memory for analog output. 512 bytes: SB memory for status info.
IP Address		IPv4 range: 0.0.0.1 to 223.255.255.254 (Default 192.168.3.100) First 3 octets set by using IO Configurator Tool. Last octet set by hardware switch.
Subnet mask		Default: 255.255.255.0
Gateway Address		Default... (No gateway)
Physical Layer		10/100BASE-T
Cable for Fieldbus Communication		Ethernet standard compliant products cable Cat5e or higher, shielded twisted pair cable
Maximum Cable Distance		100 meters
Network Topology		Line, Tree, Star, Ring
Number of IO Modules		63 maximum (including system modules *1)
Terminal Block (Removable push type)		8 Point
Recommended Wire Specifications		0.5 sq. mm to 2.0 sq. mm (AWG 20 to 14), Solid wire or Stranded (flexible) wire with lugs
Module Dimensions (H x W x D) in mm		105 x 60 x 92

NOTE

*1 Digital and analog IO modules are intelligent modules and provide IO data and diagnostics to Header module. System modules are passive modules. So, Header module does not provide any information about system modules. Header module cannot detect presence of System modules in a modular IO station. So, System modules do not appear in the list after scan.

Module M-EIP-H is supported in Modular IO Configurator Tool [V1.5.0.0] and onwards.

Ethernet/IP™ Communication Specifications

The table below provides Ethernet/IP™ communication specifications.

Specification		Description
Class 1 communications	Communication format	Instance communications
	Communication data size	Input data: 1152 bytes (Digital inputs, Analog inputs and Status data) Output data: 640 bytes (Digital outputs and Analog outputs)
	Transmission trigger	Cyclic, Change of State
	Connection Type	Point-to-point, multicast
	RPI (Communication cycle) Max	2000 to 60,000,000µs (Default 5000 µs)
Class 3 communications	Communication format	Message communication
	Communication direction	Server: Available. Client: Not available
	Communication data size	1414 bytes
UCMM communications	Communication format	Message communication
	Communication direction	Server: Available, Client: Not available
	Communication data size	1414 bytes
Maximum number of CIP connections		8
PPS (Communication processing performance)		1200 PPS (at 500 bytes)
Certification		ODVA conformance tested to EtherNet/IP™ specifications

Wiring: Module Supply

The figure shows Header module front alongwith system power supply connections and field power supply connections. Wiring description is provided on right side wall of the module.

For common wiring recommendations, refer section [Wiring](#).

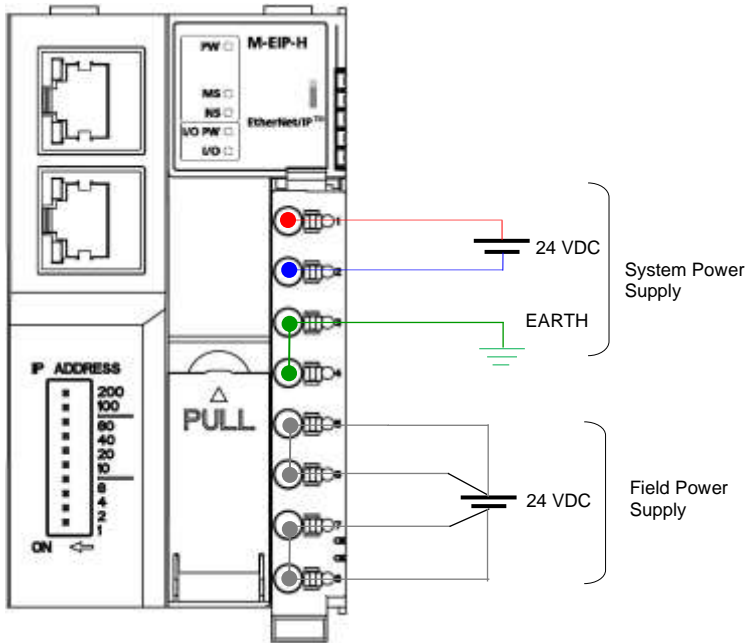

M-EIP-H: Wiring description

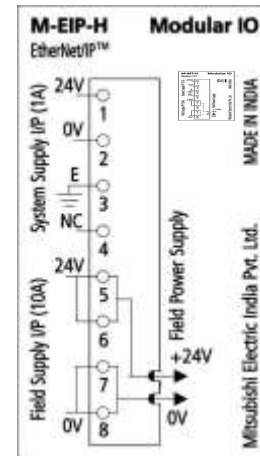

Connect +24 VDC system power supply between first two terminals (i.e. terminal 1 and 2).

Connect terminals 3/ 4 to clean EARTH directly.

Connect +24 VDC field power supply to terminal numbers 5 and 6.

Connect field power supply ground to terminal numbers 7 and 8.

NOTE

Current carrying capacity of each terminal is 5A max. So, it is necessary to connect 2 wires from the source of field power supply to utilize maximum capacity of 10 A of Field power supply interface between modules.

Field power supply connected to terminal block is directly carried to field power supply pins for interfacing with IO modules.

Ensure that EARTH cable is thick and short as far as possible to provide a low impedance path.

LED Indications



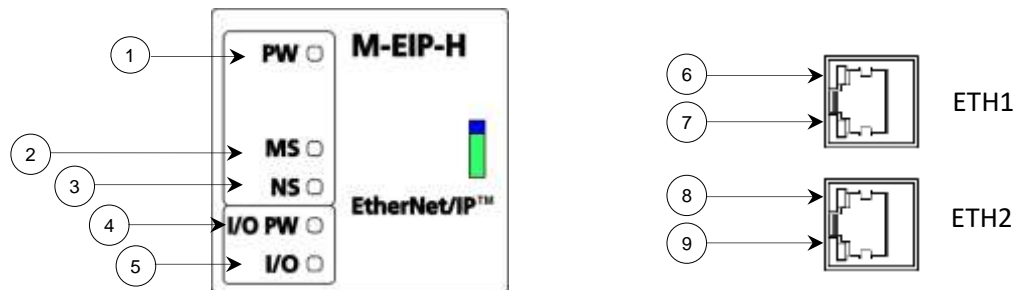

This section provides the meaning of LED indications available on Header module.

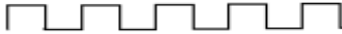

No.	LED	Colour	Status	Description
1	PW	Green	ON	System power to Header module is ON
		--	OFF	System power to Header module is OFF
2	MS	--	OFF	System power to Header module is OFF
		Green	ON	Device operational
		Red	Blinking Slow	Major Recoverable Fault <ul style="list-style-type: none"> - Invalid configuration - IO module mismatch Minor recoverable fault <ul style="list-style-type: none"> - IP address changed after power ON.
		Red	ON	Major Unrecoverable Fault <ul style="list-style-type: none"> - Hardware fault
3	NS	--	OFF	Not powered
		Green	Blinking Slow	One of the following reasons, <ul style="list-style-type: none"> - No connections - Duplicate IP address - Invalid IP address.
			ON	Device on-line and has at least one CIP connection been established
		Red	Blinking Slow	One or more CIP connection timeout occurred.
4	I/O PW	Green	ON	Field power to Header module is ON
		--	OFF	Field power to Header module is OFF
		Green	Blinking Fast	Header module is in factory test mode

5	I/O	--	OFF	Header module is powered OFF OR Hardware failure error detected in header module
		Green	ON	Header module is powered ON and communicating with IO module and no error is present.
		Green	Single Flash	Module is powered ON and ready for communication with IO modules. No IO module is detected.
		Red	ON	Invalid configuration detected. During configuration download Backplane bus major error (bus off) detected. Backplane bus function not started.
		Red	Single Flash	Different module detected as compared with configuration in one or more slots.
		Red	Double Flash	Communication error observed with one or more IO modules.
		Red	Triple Flash	Fatal error (Except IO Module mismatch or communication error) is observed for one or more IO modules, OR IO module related error is observed for one or more modules. [This includes sensor wire break, no 24V detected by IO module etc.]
		Yellow	ON	Output test mode is ON.
6,8	SPEED	Green	ON	Link up 100Mbps
		--	OFF	Link down or Link up with 10Mbps
7,9	SD/RD	--	OFF	No link established
		Green	ON	Link established
			Blinking Fast	Transmit / receive activity is in progress.

LED indication states and flashing rates

Indication State	Description
Blinking fast	Equal ON and OFF time. Approximately 250ms. 
Blinking slow	Equal ON and OFF time. Approximately 500ms. 
Single Flash	One short single flash followed by long OFF time. Short ON Time = 250ms Long OFF Time :1000ms 
Double Flash	Two short flashes followed by long OFF time. Short ON Time = Short OFF time = 250ms Long OFF Time :1000ms 
Triple Flash	Two short flashes followed by long OFF time. Short ON Time = Short OFF time = 250ms Long OFF Time :1000ms 

Setting of IP Address

This section provides information about setting of station IP address on Header module.

The first three octets of IP address are configured using Modular IO Configuration Tool and the fourth octet is set using DIP switches as shown below.

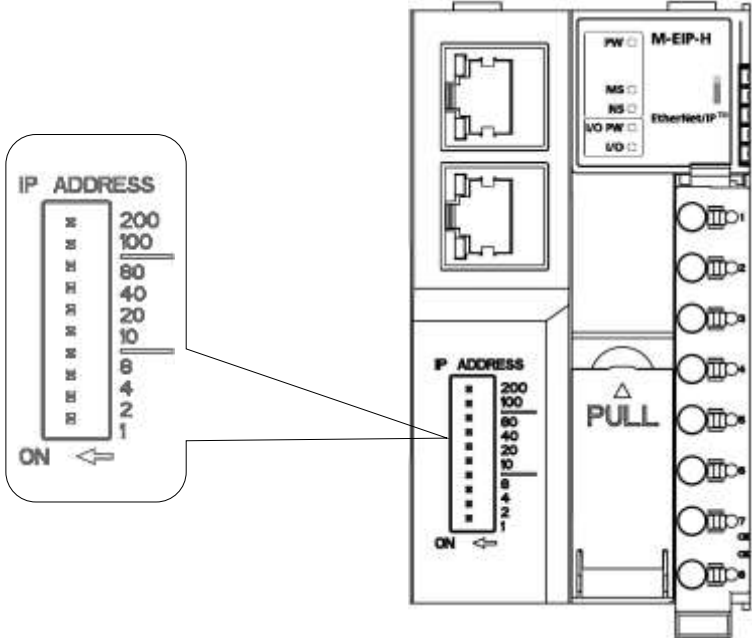

Example below shows DIP switch setting for value of 235.

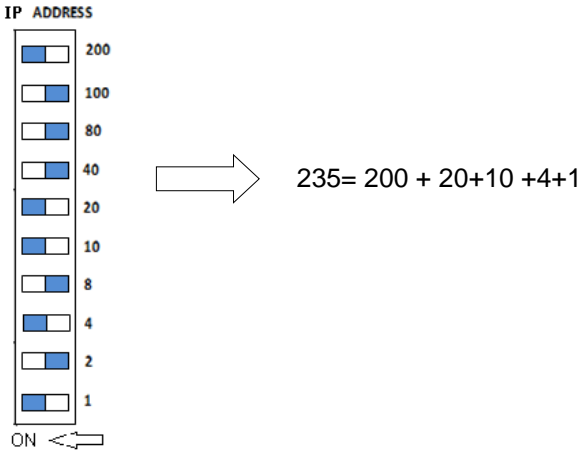

Meaning of DIP switch positions:

DIP Switch Setting	Descriptions
0 or >=255	IP address (all the four octets) is set as per parameter setting 'IP address' of modular IO configurator.
1-254	4 th octet of IP address is set according to DIP switch

NOTE

Subnet mask and Gateway address are always received from parameter setting in IO Configurator Tool.

Memory Mapping

Process data of IO modules connected to the M-EIP-H is stored in 'Local IO data memory' of module.

Following figure shows local IO data memory M-EIP-H:

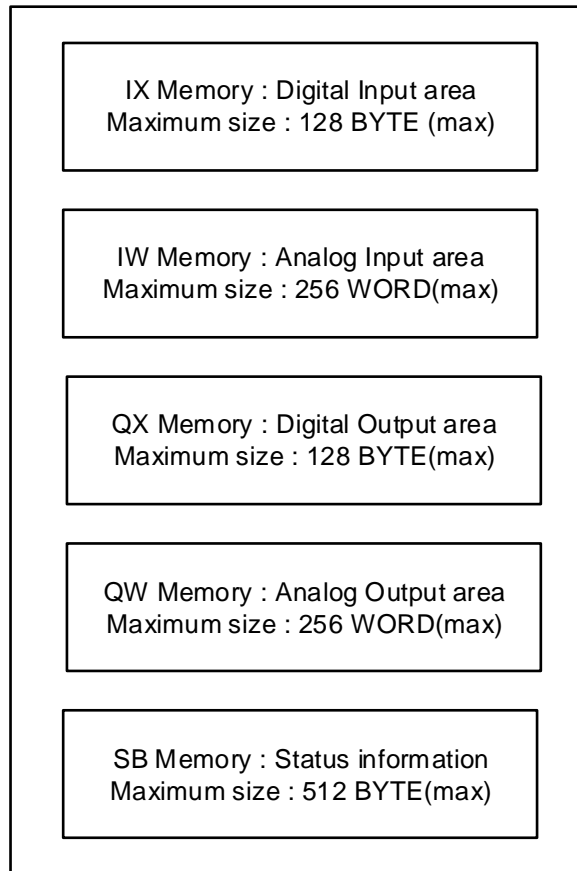

The 'Local IO data memory' of 'M-EIP-H' is mapped to 'Assembly objects'. Following instances of objects are implemented.

Instance (decimal)	Size	Descriptions
100	Default: 128 bytes Max: 640 bytes	Digital output (QX) + Analog output (QW)
110	Default: 128 bytes Max: 1152 bytes	Digital input (IX) + Analog input (IW) + Status (SB) data

Following use cases shows example mapping of Local IO data memory to assembly objects

Example of 'Modular IO station

SLOT		0	1	2	3	4	5	6	7	8	9	10	Total Size	
Module		M-EIP-H	M-16D	M-16D	M-16D	M-16TE	M-8TE	M-AD4	M-UAD2	M-8D	M-DA2	M-DA2		
Default IO data size in bytes	IX	Size	0	2	2	2	0	0	0	0	1	0	0	7
		Addr		IX0-IX1	IX2-IX3	IX4-IX5					IX6			
	IW	Size	0	0	0	0	0	0	8	4	0	0	0	12
		Addr							IW0-IW4	IW5-IW6				
	QX	Size	0	0	0	0	2	1	0	0	0	0	0	3
		Addr					QX0-QX1	QX2						
	QW	Size	0	0	0	0	0	0	0	0	0	4	4	8
		Addr										QW0-QW1	QW2-QW3	
	SB	Size	10	0	0	0	0	0	2	3	0	2	2	19
		Addr	SB0-SB9						SB10-SB11	SB12-SB14		SB15-SB16	SB17-SB18	

Mapping of assembly instances

Assembly Instance	Size
100	QX size + QW Size = 3 bytes + 8 bytes = Total 11 bytes
110	IX size + IW size+ SB size =7 bytes + 12 bytes + 19 bytes = Total 38 bytes

NOTE

The default size of input and output assembly instances is 128.

Users can change assembly instance size while configuring connection with scanner.

Consider the following cases where size of assembly instance configured while configuring connection in scanner does not match with actual IO data size of modular IO station.

Condition	Input Memory	Output memory
Size of IO data configured in connection more than actual IO data size of modular IO station. Example: Size of IO data in connection configuration 128 bytes input and 128 bytes output. Actual IO data at module IO station 30 bytes Input (IX+IW+SB) and 25 bytes output (QX+QW)	Modular IO station will send additional input data as 0.	Additional output data received from scanner is ignored by modular IO station and will not be updated to any physical output.
Size of IO data configured in connection less than actual IO data size of modular IO station. Example: Size of IO data in connection configuration 20 bytes input and 20 bytes output. Actual IO data at module IO station 30 bytes Input (IX+IW+SB) and 25 bytes output (QX+QW)	Modular IO station will send input data per connection configuration other input data will remain unmapped.	Modular IO station will update output data per connection configuration other outputs on modular IO station will remain unmapped and will be set to 0.

Input Mapping

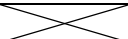
Module		Input Assembly Instance (110)		
Slot	Module name			
1	M-16D	WORD 0	IX1	IX0
2	M-16D	WORD 1	IX3	IX2
3	M-16D	WORD 2	IX5	IX4
8	M-8D	WORD 3	Reserved	IX6
6	M-AD4	WORD 4	IW0	
		WORD 5	IW1	
		WORD 6	IW2	
		WORD 7	IW3	
7	M-UAD2	WORD 8	IW4	
		WORD 9	IW5	
0	M-EIP-H	WORD 10	SB1	SB0
		WORD 11	SB3	SB2
		WORD 12	SB5	SB4
		WORD 13	SB7	SB6
		WORD 14	SB9	SB8
6	M-AD4	WORD 15	SB11	SB10
7	M-UAD2	WORD 16	SB13	SB12
		WORD 17	SB15	SB14
8	M-DA2	WORD 18		SB17
9	M-DA2	WORD 19		

Output mapping

Module		Output assembly instance (100)		
Slot	Module name			
4	M-16TE	WORD 0	QX1	QX0
5	M-8TE	WORD 1		QX2
9	M-DA2	WORD 2	QW0	
		WORD 3	QW1	
10	M-DA2	WORD 4	QW2	
		WORD 5	QW3	

Parameters

Configure modular IO station with header as explained in section '[Configure Modular IO station with Header](#)'.

Set the following parameters using Modular IO Configurator.

Parameter Name	Project Value	Comment
IP Address	192.168.3.100 (Default)	Header IP address Change to appropriate value as per network requirement.
Subnet mask	255.255.255.0 (Default)	Subnet mask Change to appropriate value as per network requirement.
Gateway Address	. . . (Default)	Gateway Address Change to appropriate value as per network requirement.
Action on fatal error	Stop N/W Communication	This parameter defines whether to continue or stop Ethernet/IP™ communication when FATAL error (IO module mismatch or communication error) is observed for one or more modules in the modular IO station.
	Continue N/W Communication [Default]	
Output hold/ clear	Hold	Defines output state of IO modules when disconnected from network or master CPU is not in run mode.
	Clear [Default]	

IO Data

User can monitor following Header diagnostics in SB memory.

Diagnostic summary	Data Type	Local Address*	Bit Status	Description
Hardware failure	BOOL	SB 0.0	TRUE	Becomes TRUE, if hardware error on Header module occurs.
			FALSE	
Configuration error	BOOL	SB 0.1	TRUE	Becomes TRUE, if invalid configuration data is downloaded in Header module.
			FALSE	
IO module mismatch error	BOOL	SB 0.2	TRUE	Becomes TRUE, if IO module configured in one or more slots is different than the physically present IO module.
			FALSE	
IO module COM error	BOOL	SB 0.3	TRUE	Becomes TRUE, if data exchange between Header and one or more IO modules is stopped after successful data exchange.
			FALSE	
Reserved	BOOL	SB 0.4	--	--
Reserved	BOOL	SB 0.5	--	--
Fatal error in one or more slots	BOOL	SB 0.6	TRUE	Becomes TRUE, if fatal error occurs in one or more IO slots.
			FALSE	
Non-fatal error in one or more slots	BOOL	SB 0.7	TRUE	Becomes TRUE, if non-fatal error occurs in one or more IO slots.
			FALSE	
Reserved	BOOL	SB 1.0	--	--
Additional IO modules detected	BOOL	SB 1.1	TRUE	Becomes TRUE, if Header module detects additional IO modules (other than configured one) at modular IO station.
			FALSE	
EEPROM error detected	BOOL	SB 1.2	TRUE	Becomes TRUE, if EEPROM error on Header module occurs.
			FALSE	

Backplane bus fault	BOOL	SB 1.3	TRUE	Becomes TRUE, if Backplane bus fault error on Header module occurs.
			FALSE	
Reserved	BOOL	SB 1.4	--	--
Reserved	BOOL	SB 1.5	--	--
Reserved	BOOL	SB 1.6	--	--
Reserved	BOOL	SB 1.7	--	--

User can monitor slot status.

Slot status	Data Type	Local Address*	Bit Status	Description
Slot status 0..7				
Slot 0	BOOL	SB 2.0	TRUE	Module is configured and working Ok in slot 0. (Slot 0 module is header)
			FALSE	Module is either not configured in slot 0 or having error. (Slot 0 module is header)
Slot 7	BOOL	SB 2.7	TRUE	Module is configured and working Ok in slot 7.
			FALSE	Module is either not configured in slot 7 or having error.
Slot status 8..15				
Slot 8	BOOL	SB 3.0	TRUE	Module is configured and working Ok in slot 8.
			FALSE	Module is either not configured in slot 8 or having error.
Slot 15	BOOL	SB 3.7	TRUE	Module is configured and working Ok in slot 15.
			FALSE	Module is either not configured in slot 15 or having error.
Slot status 56..63				
Slot 56	BOOL	SB 9.0	TRUE	Module is configured and working Ok in slot 56.
			FALSE	Module is either not configured in slot 56 or having error.
Slot 63	BOOL	SB 9.7	TRUE	Module is configured and working Ok in slot 63.
			FALSE	Module is either not configured in slot 63 or having error.

*For more details of error observed for module in particular slot, refer section "IO Data" for individual IO module in this manual. Header diagnostic data is available in Status Byte (SB) memory.

Also, refer section '[List of Station Error Codes](#)' for details of Error codes displayed in Modular IO configurator tool.

Header diagnostics

Detailed diagnostic of header module (Header diagnostics) can be monitored in Modular IO Configurator tool.

Refer section '[Header diagnostics and slot diagnostics](#)' for more details.

For M-EIP-H, following status and diagnostic information is available

Diagnosics	Description
Identification	
Vendor code	Vendor code of manufacturer. 00: Mitsubishi Electric India.
Ordering code	Ordering code of header module. M-CCB-H : For CC-Link IE Field Basic Header module
Version Info	
Device version	Device version of header module.
Hardware version	Hardware version of header module.
Firmware version	Firmware version of header module.
Backplane bus version	Backplane bus version of header module.
Hardware	
EEPROM checksum	EEPROM checksum.
Self-diagnostic test	Bitwise status of self-tests at start up.
ROM test	Result of ROM test (0: No error, 1: Error)
RAM test	Result of RAM test (0: No error, 1: Error)
Reserved	--
EEPROM test	Result of EEPROM test (0: No error, 1: Error)
MAC ID test	Result of MAC ID test (0: No error, 1: Error)
DIP switch setting	DIP switch setting to set IP address of Header module
Switch 1	Status of DIP switch 1: ON, 0 OFF
Switch 2	Status of DIP switch 1: ON, 0 OFF
Switch 10	Status of DIP switch 1: ON, 0 OFF
IP setting	
IP address	Header IP address.
Subnet mask	Subnet mask.
MAC ID	Header MAC ID.
Memory size	
IX	Configured size of bit input image (IX) No. of bytes
IW	Configured size of word input image (IW).No. of bytes
QX	Configured size of bit output image (QX). No. of bytes
QW	Configured size of word output image (QW) No. of bytes
SB	Configured size of diagnostic (SB) image No. of bytes
Current	Header scan time.
Maximum	Maximum header scan time.

Minimum	Minimum header scan time.
Diagnostics summary	
No. of configured slots	Number of configured slots.
No. of detected slots	Number of detected slots.
Status	Bitwise status of header module.
Hardware failure	Hardware failure detected. Check self-diagnostic test results.
Configuration error	Invalid configuration detected for header.
IO module mismatch	Module absent or different module present in one or more slots.
IO module COM error	Module communication error detected during runtime.
Reserved	--
Reserved	--
Slot fatal error	Fatal error detected for one or more slots.
Slot non-fatal error	Non-fatal error detected for one or more slots.
Reserved	--
Additional IO modules detected	Number of IO modules detected are more than number of IO modules configured.
Slots 0-15	
Detected	Bitwise module detection status.
Healthy	Bitwise module health status.
IO error	Bitwise status of module mismatch or absent.
COM error	Bitwise status of COM error after power ON
Fatal error	Bitwise (slotwise) status of module fatal error.
Non-fatal error	Bitwise status of module non-fatal error
Slots 48-63	
Detected	Bitwise module detection status.
Healthy	Bitwise module health status.
IO error	Bitwise status of module mismatch or absent.
COM error	Bitwise status of COM error after power ON
Fatal error	Bitwise (slotwise) status of module fatal error.
Non-fatal error	Bitwise status of module non-fatal error
Interface (ETH1)	
Interface status	Current interface status (0 : Link down, 1: Link up)
Interface speed	10 or 100
Interface (ETH2)	
Interface status	Current interface status (0 : Link down, 1: Link up)
Interface speed	10 or 100
Ethernet Link (ETH1)	
Received byte count	Number of bytes received
Received unicast frames count	Number of unicast frames received
Received non unicast frames count	Number of non-unicast frames received
Sent byte count	Number of bytes transmitted
Sent unicast frames count	Number of unicast frames transmitted
Sent non unicast frames count	Number of non-unicast frames transmitted
Large error count	Number of frames received with large frame error

Align error count	Number of frames received with alignment error
FCS error count	Number of frames received with CRC/FCS error
Receive error count	Number of frames with other receive errors
Single collision count	Number of frames transmitted after single collision
Multi collision count	Number of frames transmitted after multiple collisions
Drop count	Number of frames dropped after excessive collisions
Sent error count	Number of frames with other transmit errors
Ethernet Link (ETH2)	
Received byte count	Number of bytes received
Received unicast frames count	Number of unicast frames received
Received non unicast frames count	Number of non-unicast frames received
Sent byte count	Number of bytes transmitted
Sent unicast frames count	Number of unicast frames transmitted
Sent non unicast frames count	Number of non-unicast frames transmitted
Large error count	Number of frames received with large frame error
Align error count	Number of frames received with alignment error
FCS error count	Number of frames received with CRC/FCS error
Receive error count	Number of frames with other receive errors
Single collision count	Number of frames transmitted after single collision
Multi collision count	Number of frames transmitted after multiple collisions
Drop count	Number of frames dropped after excessive collisions
Sent error count	Frames with other transmit errors
CIP Diagnostics	
Open CIP connections count	Number of currently open CIP Connections
Open requests	Number of received Forward_Open services
Open format rejects	Number of Forward_Open services rejected due to format incompatibility
Open resource rejects	Number of Forward_Open services rejected due to insufficient resources
Open other rejects	Number of Forward_Open services rejected due to reasons other than format incompatibility and insufficient resources
Close requests	Number of received Forward_Close services
Close format requests	Number of Forward_Close services rejected due to format incompatibility
Close other requests	Number of Forward_Close services rejected due to reasons other than format incompatibility
Connection timeouts	Total number of connection timeouts that occurred in connections controlled by the Connection Manager
DLR	
DLR : Network topology	0: Line, 1: Ring
DLR : Network status	If network topology = Line Always 0 (Normal) If network topology = Ring 0: Normal, 1: Ring Faulted, 2:Unexpected loop detected, 3:partial network fault, 4: Rapid fault / Restore cycle
DLR : Supervisor MAC Address	Supervisor MAC address

5.4 M-CCIEF-H (CC-Link IE Field)

[CC-Link IE Field Header Module]

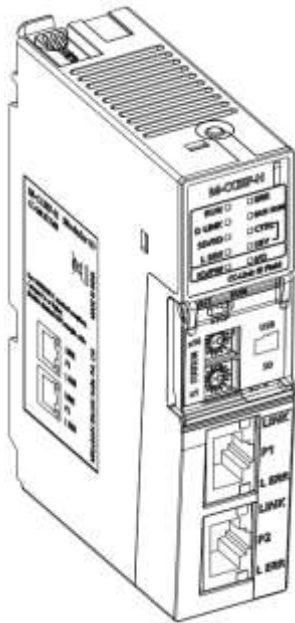

[Module Overview](#)

[Part Names](#)

[Specifications](#)

[Wiring: Module Supply](#)

[LED Indications](#)

[Setting of Station number](#)

[Memory Mapping](#)

[Parameters](#)

[IO Data](#)

[Header Diagnostics](#)

Module Overview

M-CCIEF-H Header module is a intelligent device station in a CC-Link IE Field network.

NOTE

The header module "M-CCIEF-H" supports "CC-Link IE Field" and "CC-Link IE TSN" protocols. Protocol is user configurable. User can choose the protocol using the "Bus type" setting while creating project in the Modular IO Configurator tool.

Support for CC-Link IE TSN protocol is available for Header Version 1.1.0.0 and Modular IO Configurator tool Version 2.1.0.0;

Earlier versions (Header Version 1.0.0.0 and Modular IO Configurator tool Version 2.0.0.0) of the header module and the Modular IO Configurator support only "CC-Link IE Field."

Part Names

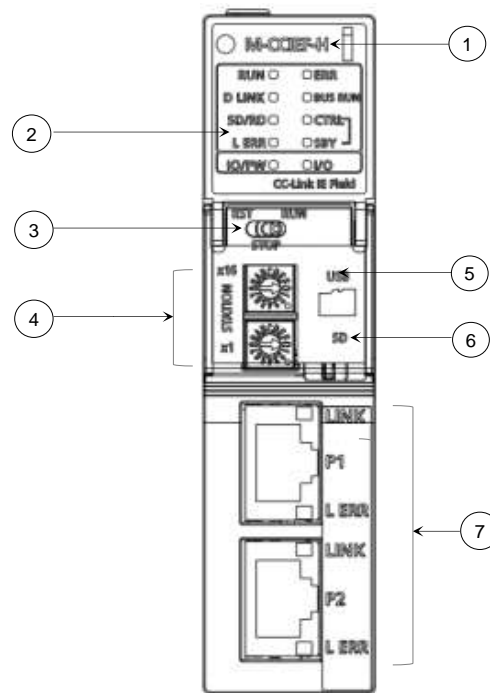

No.	Name	Description						
1	M-CCIEF-H	Module ordering code						
2	Module Indications	10 nos. of module level LED indications are provided as below, RUN, ERR, D LINK, BUS RUN, SD/RD, CTRL, L ERR, SBY, I/O and I/O PW.						
Front door is fixed to cover operation mode switch, rotary switch, USB port and SD memory card socket.								
3	Operation Mode Switch	3 - position toggle switch to set operation mode.						
		<table border="1"> <thead> <tr> <th>Switch position</th> <th>Functional details</th> </tr> </thead> <tbody> <tr> <td>RUN</td> <td>Sets header module to RUN mode. In RUN mode, the cyclic transmission is started between master station and header module.</td> </tr> <tr> <td>STOP</td> <td>Sets header module to STOP mode. When the module is in the STOP state, <ul style="list-style-type: none"> Digital outputs (RY) are turned off Analog outputs (RWw) are set to output 0 signal. </td> </tr> </tbody> </table>	Switch position	Functional details	RUN	Sets header module to RUN mode. In RUN mode, the cyclic transmission is started between master station and header module.	STOP	Sets header module to STOP mode. When the module is in the STOP state, <ul style="list-style-type: none"> Digital outputs (RY) are turned off Analog outputs (RWw) are set to output 0 signal.
		Switch position	Functional details					
RUN	Sets header module to RUN mode. In RUN mode, the cyclic transmission is started between master station and header module.							
STOP	Sets header module to STOP mode. When the module is in the STOP state, <ul style="list-style-type: none"> Digital outputs (RY) are turned off Analog outputs (RWw) are set to output 0 signal. 							

No.	Name	Description		
			<ul style="list-style-type: none"> Cyclic transmission with the master station is stopped. 	
		RESET	Resets header module. Hold switch at RESET position for a second.	
4	Rotary Switches for Station Number Setting	Sets the station number (1 to 120) Rotary switches x16 and x1 (hexadecimal). Refer section Setting of Station Number for more details.		
5	USB Port (USB 2.0)	USB port used for configuration download and firmware download.		
6	SD Card socket	Not supported.		
7	Ethernet ports	P1 and P2	Port connectors for the connection of CC-Link IE Field network. Connect an Ethernet cable.	
			L ERR LED	Indicates the port status.
			LINK LED	Indicates the link status.

Specifications

The table below provides technical specifications of **M-CCIEF-H**.

Specification		Description
Module Ordering Code		M-CCIEF-H
External Connections	Network Communication	RJ45 female- 2 nos.
	Configuration Port	USB 2.0
Fieldbus Support		CC Link IE Field
Maximum Number of Link Points Per Station	RX	1K points (1024 points, 128 bytes)
	RY	1K points (1024 points, 128 bytes)
	RWr	1K points (1024 points, 2K bytes)
	RWw	1K points (1024 points, 2K bytes)
Station Type		Intelligent device station
Station Number		1 to 120 (settable by rotary switches x16 and x1 (hexadecimal))
Network Number		1 to 239
Communication Speed		1Gbps
Network Topology		Line topology, star topology (coexistence of line topology and star topology is also possible), and ring topology
Communication Cable		Ethernet cable which satisfies 1000BASE-T standard: Category 5e or higher, straight cable (double shielded, STP)
Maximum Station-to-Station Distance		100m (conforms to ANSI/TIA/EIA-568-B (Category 5e))
Number of I/O Points (Local memory)	IX	1K points (1024 points, 128 bytes)
	QX	1K points (1024 points, 128 bytes)
	IW	1K points (1024 points, 2K bytes)
	QW	1K points (1024 points, 2K bytes)
	SB	512 points (512 bytes)
Configurable Slots (on base module) ^{*1}		Header slot.
Hot Swapping		Supported.
Internal Current Consumption (5 Vdc)		0.75A or less
Number of IO Modules		63 maximum (including system modules ^{*2})
Dimensions (H x W X D) mm		105 x 27 x 72
Weight (in grams)		130

^{*1} Mechanical coding on base module and back side of Header module ensures that M-APSU module cannot be fixed in Header slot as well as M-CCIEF-H module cannot be fixed in PSU slot.

^{*2} Digital and analog IO modules are intelligent modules and provide IO data and diagnostics to Header module. System modules are passive modules. So, Header module does not provide any information about system modules. Header module cannot detect presence of System modules in a modular IO station. So, System modules do not appear in the list after scan.

Wiring

The figure below shows M-CCIEF-H header wiring details. Wiring information is provided on left side wall of the module. Two Ethernet ports (P1 and P2) are provided on the front side of the module.

For common wiring recommendations, refer section [Wiring](#).

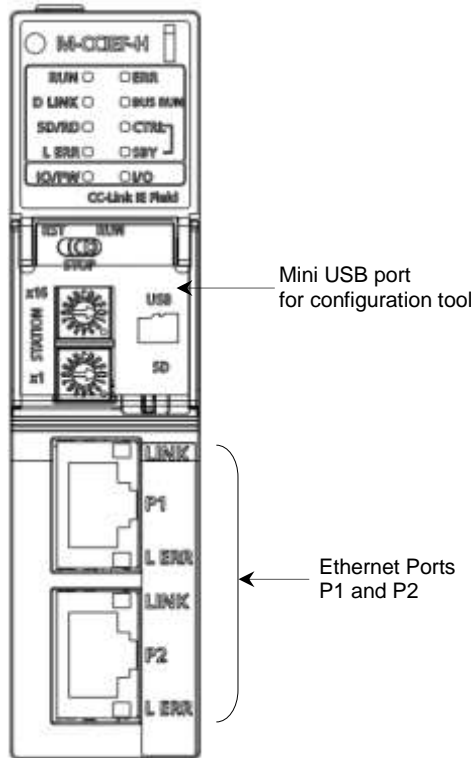

M-CCIEF-H: Wiring description

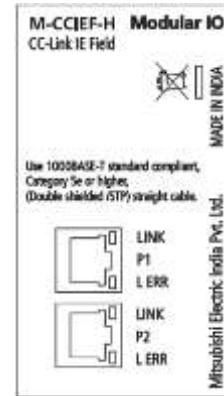

Connecting the Ethernet cable

1. Push the Ethernet cable connector into the port until it clicks. Pay attention to the connector's direction. Connector latch should be on right side.
2. Lightly pull it to check that it is securely connected.
3. Check whether the LINK LED of the port connected with an Ethernet cable is on.

NOTE

Both P1 connector and P2 connector can be used.

- When only one connector is used in star topology, either P1 connector or P2 connector is applicable.
- When two connectors are used in line topology and ring topology, the cable can be connected between P1 and P1, P2 and P2, or between P1 and P2 as shown below.

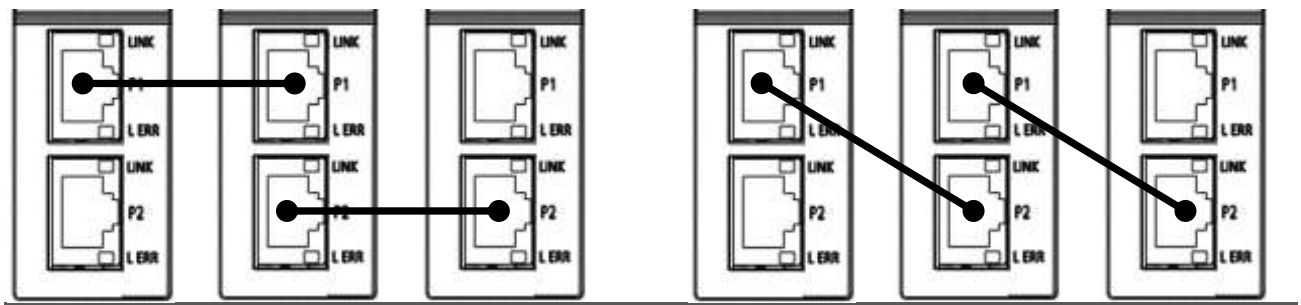

Disconnecting the Ethernet cable

1. Press the latch towards the left side and unplug the Ethernet cable.

Precautions

- Place the Ethernet cable in a duct or clamp them. If not, dangling cable may swing or inadvertently be pulled, resulting in damage to the module or cables or malfunction due to poor contact.
- Do not touch the core of the cable-side or module-side connector and protect it from dirt or dust. If oil from your hand, dirt or dust is attached to the core, it can increase transmission loss, arising a problem in data link.
- Check that the Ethernet cable is not disconnected or not shorted and there is no problem with the connector connection.
- Do not use Ethernet cables with broken latches. Doing so may cause the cable to become unplugged or malfunction.
- Hold the connector part when connecting and disconnecting the Ethernet cable. Pulling the cable connected to the module may result in damage to the module or cable or malfunction due to poor cable connection.
- The maximum station-to-station distance of the Ethernet cable is 100m. However, the length may be shorter depending on the operating environment of the cable. For details, contact your cable manufacturer.
- The bend radius of the Ethernet cable is limited. For details, check the specifications of the Ethernet cable to be used.

LED Indications

This section provides the meaning of LED indications on Header module.

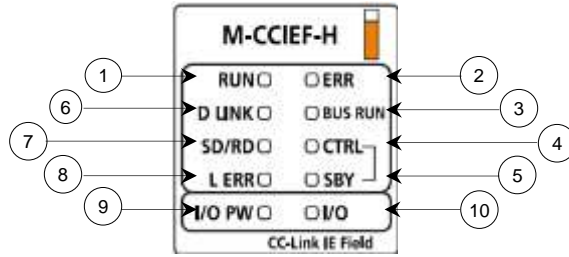

No.	LED	Colour	Status	Description
1	RUN	Green	--	* Refer table LED status explained in this section.
2	ERR	Red	--	
3	BUS RUN	Green	ON	Indicates header module is in RUN mode. In RUN mode, the cyclic transmission is started between master station and header module.
			OFF	Indicates header module is in STOP mode. The module switches to STOP mode due to following causes, - RUN/ STOP switch is set to STOP position. - Network master stations is in STOP state when connected. - Remote STOP is detected. - Fatal error occurred at slave station.
4	CTRL	Green	ON	Indicates header module is operating as control system in active-active configuration.
			Blinking	Indicates header module is operating in non-redundant mode. For this condition, header shows non-fatal error code 2006H.
			OFF	Indicates header module not operating as a control system.
5	SBY	Green	ON	Indicates header module is operating as standby system in active-active configuration.
			OFF	Indicates header module is not-operating as standby system
			Blinking	Reserved
6	D LINK	Green	ON	Indicates cyclic transmission being performed.
			Blinking	Indicates cyclic transmission is stopped.
			OFF	Indicates cyclic transmission is not performed (disconnection)
7	SD/ RD	Green	ON	Data transmission or reception is in progress.
			OFF	No data transmission or reception.
8	L ERR	Red	ON	Indicates abnormal data reception.
			OFF	Indicates normal data reception.
9	I/O PW	Green	ON	Field power is connected to I/O Adapter module fixed in Header assembly.
			OFF	Field power is not connected to IO Adapter module in Header assembly.

*For more details of LED indication states and flashing rates, refer section [Troubleshooting >> LED indications: States and flashing rates](#) in this manual.

10	I/O (Bi colour)	Blue Green	ON	Header module is communicating with attached IO module/s and no error is present.
			Single flash	Header module is ready for communication with IO modules. No IO module is detected.
		Red	ON	One of the following conditions occurred, <ul style="list-style-type: none"> - Invalid configuration detected. - No communication with I/O modules due to backplane bus fault - Backplane bus communication not started. - Header configuration download is in progress
			Single Flash	IO module mismatch detected for one or more IO slots.
			Double Flash	Communication error observed with one or more IO modules.
			Triple Flash	One of the following conditions occurred, <ul style="list-style-type: none"> - Fatal error (Except IO Module mismatch or communication error) is observed in one or more IO modules. - IO module related error is observed for one or more modules. This includes sensor wire break, no 24V detected by IO module, etc.
		--	OFF	One of the following conditions occurred, <ul style="list-style-type: none"> - Header module is powered OFF. - Hardware failure error detected in header module.

Ethernet Ports (P1 and P2) ports are used for network connection as below,

Port P1	L ERR	Amber	ON	Indicates abnormal data reception.
			OFF	Indicates normal data reception.
	LINK	Green	ON	Link is up.
			OFF	Link is down.
Port P2	L ERR	Amber	ON	Indicates abnormal data reception.
			OFF	Indicates normal data reception.
	LINK	Green	ON	Link is up.
			OFF	Link is down.

*** LED Status**

LED status		Description
RUN	ERR	
ON	OFF	Normal operation
	ON	IO module level fatal error
	Blinking x1	Non-fatal error
Blinking x3	OFF	Reserved
	ON	
	Blinking x1	
Blinking x1	Blinking x2	Reserved
	ON	
	OFF	
OFF	ON	Header assembly module level fatal error
	Blinking x1	Initial processing

Setting of Station Number

Two rotary switches x1 and x16 (hexadecimal) are provided on the front side of Header module.



For setting station number with rotary switches, make use of a flat head screwdriver with a tip width of 2.5 mm.

Set the station number between 1 to 120. Combination setting of x1 and x16 are as follows.

		x1 setting															
		0	1	2	3	4	5	6	7	8	9	A	B	C	D	E	F
x16 setting	0		1	2	3	4	5	6	7	8	9	10	11	12	13	14	15
	1	16	17	18	19	20	21	22	23	24	25	26	27	28	29	30	31
	2	32	33	34	35	36	37	38	39	40	41	42	43	44	45	46	47
	3	48	49	50	51	52	53	54	55	56	57	58	59	60	61	62	63
	4	64	65	66	67	68	69	70	71	72	73	74	75	76	77	78	79
	5	80	81	82	83	84	85	86	87	88	89	90	91	92	93	94	95
	6	96	97	98	99	100	101	102	103	104	105	106	107	108	109	110	111
	7	112	113	114	115	116	117	118	119	120							
	8																
	9																
	A																
	B																
	C																
	D																
	E																
	F																

NOTE

- Station number of Header module can be set either by rotary switches or by parameter setting in Modular IO Configuration tool. The example setting in the table below explains 2 methods to set station number.

Setting via rotary switches	Parameter set via Modular IO Configuration tool		Station number set for Header module
	Station number setting	Station No.	
10	'Rotary switch'	Not applicable	10
10	'Parameter'	20	20

- Station number setting is detected at power on only. So, set the station number when header module is powered off.
Non fatal error (2008H) is declared if station number is changed while power is ON.
- Station number setting from 121 to 255 are invalid. Header will declare fatal error (1013H).

Memory mapping

Local memory is mapped to header module and link devices at master station as shown below.

Memory Area	Local Address	Access	Master Station
Input bit	IX	Read	RX
Input word	IW	Read	RWr
Output bit	QX	Write	RY
Output word	QW	Write	RWw
Status byte	SB	Read	RWr

NOTE

SB memory is shared with network master if "Share SB to RWr" parameter is set as Enable'.
Both IW and SB memories are mapped to RWr memory. IW memory is mapped first, followed by SB memory.

Parameters

Configure modular IO station with header assembly as explained in section ‘[Configure Modular IO station with Header Assembly](#)’.

Set the following parameters using Modular IO Configuration tool.

Parameter Name	Project Value	Comment
General parameters		
Action on fatal error	Continue N/W communication [Default]	Defines action on fatal error. Stop or continue communication with network master.
	Stop N/W communication	
Share SB to RWr	Disable [Default]	Enables diagnostic data (SB) sharing with network master
	Enable	
Output hold/ clear	Clear [Default]	Defines output state of IO modules when disconnected from network or master CPU is not in RUN mode.
	Hold	
Share diagnostics	Enable [Default]	Enables diagnostic data (SB) updation.
	Disable	
Network parameters		
Network No.	1 [Default]	Network number setting is set 1 to 239 only when specific network number setting is required.
Station number setting	Rotary switch [Default]	Defines source of station number setting.
	Parameter	
Remote reset enable	Disable [Default]	Enables/ disables remote reset as,
	Enable	
Redundancy parameters		
Redundancy mode	Non-redundant [Default]	This defines redundancy mode of operation.
	Active-Active redundancy	

IO Data

Monitor following diagnostics in SB memory.

Diagnostic summary	Data Type	Local Address*	Bit Status	Description
Hardware failure	BOOL	SB 0.0	TRUE	Becomes TRUE, if hardware error of Header module occurs.
			FALSE	
Configuration error	BOOL	SB 0.1	TRUE	Becomes TRUE, if invalid configuration data is downloaded in Header module.
			FALSE	
Header assembly fatal error	BOOL	SB 0.2	TRUE	Becomes TRUE, in case of fatal error detected in header assembly. Refer section ' List of station Error Codes '.
			FALSE	
Header assembly non-fatal error	BOOL	SB 0.3	TRUE	Becomes TRUE, in case of non-fatal error detected in header assembly. Refer section ' List of station Error Codes '.
			FALSE	
IO module mismatch error	BOOL	SB 0.4	TRUE	Becomes TRUE, if IO module configured in slot is different than the physically present IO module.
			FALSE	
IO module COM error	BOOL	SB 0.5	TRUE	Becomes TRUE, if data exchange between Header and one or more IO modules is stopped after successful data exchange.
			FALSE	
IO module fatal error	BOOL	SB 0.6	TRUE	Becomes TRUE, in case of fatal error detected for one or more IO modules. Refer section ' List of station Error Codes '.
			FALSE	
IO module non-fatal error	BOOL	SB 0.7	TRUE	Becomes TRUE, in case of non-fatal error detected for one or more IO modules. Refer section ' List of station Error Codes '.
			FALSE	
Additional IO modules detected	BOOL	SB 1.0	TRUE	Becomes TRUE, if Header module detects additional IO modules (other than configured one) at modular IO station.
			FALSE	
Backplane bus fault	BOOL	SB 1.1	TRUE	Becomes TRUE, if backplane bus fault is detected.
			FALSE	
PSU error detected (P1/P2)	BOOL	SB 1.2	TRUE	Becomes TRUE, if power supply module related error is detected.
			FALSE	
Header redundancy failure	BOOL	SB 1.3	TRUE	Becomes TRUE, if redundancy loss is detected.
			FALSE	
Control header identification	BOOL	SB 1.4	TRUE	Becomes TRUE, if H1 is standby header and H2 is control header.
			FALSE	
Bus stopped	BOOL	SB 1.5	TRUE	Becomes TRUE, if fieldbus communication is stopped.
			FALSE	
FW error	BOOL	SB 1.6	TRUE	Becomes TRUE, if firmware watchdog error is detected.
			FALSE	
No field power supply	BOOL	SB 1.7	TRUE	Becomes TRUE, if field power supply is not detected.
			FALSE	

User can monitor slot status.

Slot status	Data Type	Local Address*	Bit Status	Description
Slot status 0..7				
Slot 0	BOOL	SB 2.0	TRUE	Header module (or header assembly) is healthy.
			FALSE	Error is detected for Header module (or header assembly).
Slot 1	BOOL	SB 2.1	TRUE	I/O module is configured in slot 1 and is healthy.
			FALSE	I/O module in slot 1 has error or I/O module is not configured in slot 1.
⋮	⋮	⋮	⋮	
Slot 7	BOOL	SB 2.7	TRUE	I/O module is configured in slot 7 and is healthy.
			FALSE	I/O module in slot 7 has error or I/O module is not configured in slot 7.
Slot status 8..15				
Slot 8	BOOL	SB 3.0	TRUE	I/O module is configured in slot 8 and is healthy.
			FALSE	I/O module in slot 8 has error or I/O module is not configured in slot 8.
⋮	⋮	⋮	⋮	
Slot 15	BOOL	SB 3.7	TRUE	I/O module is configured in slot 15 and is healthy.
			FALSE	I/O module in slot 15 has error or I/O module is not configured in slot 15.
⋮	⋮	⋮	⋮	
Slot status 56..63				
Slot 56	BOOL	SB 9.0	TRUE	I/O module is configured in slot 56 and is healthy.
			FALSE	I/O module in slot 56 has error or I/O module is not configured in slot 56.
⋮	⋮	⋮	⋮	
Slot 63	BOOL	SB 9.7	TRUE	I/O module is configured in slot 63 and is healthy.
			FALSE	I/O module in slot 63 has error or I/O module is not configured in slot 63.

Also, refer section '[List of Station Error Codes](#)' for details of Error codes displayed in Modular IO configurator tool.

Header diagnostics:

Detailed diagnostics of header module (Header diagnostics) can be monitored in Modular IO Configurator tool. Refer section '[Header diagnostics and slot diagnostics](#)' for more details.

For M-CCIEF-H, the following status and diagnostic information is available

Diagnostics	Description
Identification	
Vendor code	Vendor code of manufacturer.
Ordering code	Ordering code of header module. M-CCIEF-H : For CC-Link IE Field Header module
Version Info	
Device version	Device version of header module.
Hardware version	Hardware version of header module.
Firmware version	Firmware version of header module.
Backplane bus version	Backplane bus version of header module.
Fieldbus version	Fieldbus stack version of header module.
Hardware	
EEPROM checksum	EEPROM checksum.
Self-diagnostic test	Bitwise status of self-tests at start up.
ROM test	Result of ROM test (0: No error, 1: Error)
RAM test	Result of RAM test (0: No error, 1: Error)
Reserved	.—
EEPROM test	Result of EEPROM test (0: No error, 1: Error)
MAC ID test	Result of MAC ID test (0: No error, 1: Error)
Switch setting value (x1)	Status of rotary switch x1.
Switch setting value (x16)	Status of rotary switch x16.
Switch setting value RUN/STOP switch	Status of RUN/ STOP switch. 0: STOP, 1: RUN, 2: RESET
LED status1	LED allocation: 16#HGFEDCBA A: RUN, B: ERR, C: BUS RUN, D: D-LINK, E: CTRL, F: SD/RD, H: L ERR LED status- 0: OFF, 1: ON, 2: Blink slow, 4: Blink fast, 5: Single flash, 6: Double flash, 7: Triple flash
LED status2	LED allocation: 16#HGFEDCBA A: I/O PWRR, B: I/O RED, C: I/O GREEN LED status- 0: OFF, 1: ON, 2: Blink slow, 4: Blink fast, 5: Single flash, 6: Double flash, 7: Triple flash
Memory size	
IX	Configured size of bit input image (IX) No. of bytes
IW	Configured size of word input image (IW).No. of bytes
QX	Configured size of bit output image (QX). No. of bytes
QW	Configured size of word output image (QW) No. of bytes
SB	Configured size of diagnostic (SB) image No. of bytes
Header scan time	
Current	Header scan time.
Maximum	Maximum header scan time.

Minimum	Minimum header scan time.
MIO station diagnostics summary	
No. of configured slots	No. of configured slots.
No. of detected slots	No. of detected slots.
Header status summary	Bitwise status of header module.
Hardware failure	Hardware failure detected. Check self-diagnostic test results.
Configuration error	Invalid configuration detected for header.
IO module mismatch	Module absent or different module present in one or more slots.
IO module COM error	Module communication error detected during runtime.
Slot fatal error	Fatal error detected for one or more slots.
Slot non-fatal error	Non-fatal error detected for one or more slots.
Additional IO modules detected	Number of IO modules detected are more than number of IO modules configured.
No field power supply	No field power supply detected.
P1 power supply healthy	P1 power supply healthy.
P2 power supply healthy	P2 power supply healthy.
IO adapter module detected	IO adapter module detected.
Header 1 detected	Header 1 detected.
Header 2 detected	Header 2 detected.
Header assembly fatal error	Header assembly fatal error detected.
Header assembly non-fatal error	Header assembly non-fatal error detected.
Slots 0-15	
Configured	Bitwise module configuration status.
Healthy	Bitwise module health status.
IO error	Bitwise status of module mismatch or absent.
COM error	Bitwise status of COM error after power ON
Fatal error	Bitwise status of module fatal error.
Non-fatal error	Bitwise status of module non-fatal error
Slots 48-63	
Detected	Bitwise module detection status.
Healthy	Bitwise module health status.
IO error	Bitwise status of module mismatch or absent.
COM error	Bitwise status of COM error after power ON
Fatal error	Bitwise (slotwise) status of module fatal error.
Non-fatal error	Bitwise status of module non-fatal error
Interface(ETH1)	
Link status	Indicates the link status. 1: Link up, 0: Link down
Port status	Indicates the port status. 1: Abnormal data received, 0: Normal data received.
Cable disconnection detection count	Number of cable disconnection detected since power ON/ reset.
Interface(ETH2)	
Link status	Indicates the link status. 1: Link up, 0: Link down
Port status	Indicates the port status. 1: Abnormal data received, 0: Normal data received.
Cable disconnection detection count	Number of cable disconnection detected since power ON/ reset.
CC-Link IE Field	

Network number	Network number of own station
Station number	Station number of own station
Token pass status of own station	00: data link in progress, 02: Token pass in progress, 03: Token pass being terminated
Cause of token pass interruption	00: Normal communication or power on, 30h: Cable disconnection 33h: Disconnection of return in process
Cause of data link stop	00H: Normal, 01H: Stop direction, 02H: Monitoring time timeout 10H: Parameter not received, 11H: Station no. out of range, 12H: Reserved station 13H: Station no. duplication, 18H: Parameter error 19H: Parameter comm.in progress, 1AH: Station type mismatch 1BH: Parameer mismatch, 20H: Fatal error.
Data link stop request station	Stores the station number of the station that performed the data link stop request for the own station.
Module status of own station	01H: STOP (normal), 02H: STOP (FATAL error), 03H: RUN (Fatal error) 04H: RUN (normal), 05H: RUN (Non-fatal error), 0FH: Initial processing
Network No. set for diagnostics	Stores the network number set in the CC-Link IE Field Network diagnostics.
Station No. set for diagnostics	Stores the station number set in the CC-Link IE Field Network diagnostics.
Connection status of own station	00H: Normal (P1-OK, P2-OK), 01H: Normal (P1-OK, P2-NoCable) 04H: Normal (P1-LpBk, P2-NoCable), 10H: (P1: NoCable, P2-Normal) 11H: Disconnecting (P1, P2: NpCable), 12H: Disconnecting (P1:NoCable, P2-Init) 21H: Disconnecting (Init, NoCable), 22H: Disconnecting (P1, P2: Init) 40H: Normal (P1:NoCable, P2:LpBk)
Master station CPU status	Bitwise status of master CPU operation
Run/stop status	Run/stop status (0: RUN, 1: STOP)
Moderate / major error status of master	Moderate / major error status of master(0: No error, 1: Error)
Minor error status of master	Minor error status of master (0: No error, 1: Error)
No. of transient requests received	Number of transient requests received
No. of transient requests error	Number of transient requests error
Last transient request error details	Last transient request error code detected.
No. of cyclic transmission requests received	No. of cyclic transmission requests received.
Redundant power supply system^{*1}	
Power supply status summary	Power supply status summary bitwise
P1 – AC/DC DOWN detected	P1 power supply status (0: No AC/DC down, 1: AC/DC down)
P1 – Power-off/power supply voltage drop detected	P1 power supply status (0: No input power supply voltage drop detected, 1: Input power supply voltage drop detected)
P1 – Power supply failure detection	P1 power supply status (0:No failure detected, 1:PSU failure detected)
P2 – AC/DC DOWN detected	P2 power supply status (0: No AC/DC down, 1: AC/DC down)
P2 – Power-off/power supply voltage drop detected	P2 power supply status (0: No input power supply voltage drop detected, 1: Input power supply voltage drop detected)
P2 – Power supply failure detection	P2 power supply status (0: No failure detected, 1: PSU failure detected)
Number of AC/DC down detections (P1)	Number of AC/DC down detections (P1)
Number of AC/DC down detections (P2)	Number of AC/DC down detections (P2)
Redundant system information	
Redundancy mode	0: No redundancy, 1: Active-Active redundancy
Header module number	Header module slot number
Control system judgement	Indicates operating status of header module. 1: Control system, 2: Standby system

Standby module error details	Bitwise status of standby module. This is useful to understand reason of standby module error. Bit 0 – Not in standby module. Bit 1 – Fatal error Bit 2 - IO module fatal error Bit 3 – Fieldbus error Bit 4 – Hardware error Bit 5 – Stop state Bit 6 – Header removed / not detected. Bit 7 – Communication error
Operating status	The operation information for header is stored.
RUN	Operation information – 0: Not in RUN mode, 1: RUN mode.
STOP	Operation information – 0: Not in STOP mode, 1: STOP mode.
INITIALIZE	Operation information – 0: Not initializing, 1: Initializing.
RESET	Operation information – 0: Not RESET, 1: RESET.
Non-fatal error	Operation information – 0: No non fatal error, 1: Non fatal error.
Fatal error	Operation information – 0: No fatal error, 1: fatal error.
Reserved	--
Stop error flag	Operation information – 0: No stop error flag, 1: Stop error flag.
Reserved	--
Reserved	--
Reserved	--
Reserved	--
Reserved	--
Reserved	--
Reserved	--
Mounting status	0: Not mounted, 1: Mounted
System switching cause	0: Initial value, 1: Reset or hardware failure, 2: Fatal error, 3: Data link error 17: Request from MIO tool
Cause of system switching failure	0: System switch successful, 1: No communication with standby system 2: Communication timeout, 3: Fatal error in standby system 5: Memory copy in progress, 7: Standby data link error 10: Non fatal error in standby system
Cause of the other system monitoring error	Cause of other system monitoring error.
Fixed to 0	--
Reset or hardware failure in the other system	1: Reset or hardware failure in the other system
Fatal error in the other system	1: Fatal error in the other system
Reserved	--
Reserved	--
Reserved	--
Reserved	--
System is not available for communication	1: System is not available for communication
System switching cause(when the systems are successfully switched)	0: Initial value, 1: Reset or hardware failure, 2: Fatal error, 3: Data link error, 17: Request from MIO tool
Memory copy completion status	0: Memory copy successful, 1: Power off/absent, 2: Non compatible header.

 P2 power supply status is only applicable for configurations with M-B5 base module and power supply module is inserted in P2 slot.

5.5 M-CCIEF-H (CC-Link IE TSN)

[CC-Link IE TSN Header Module]

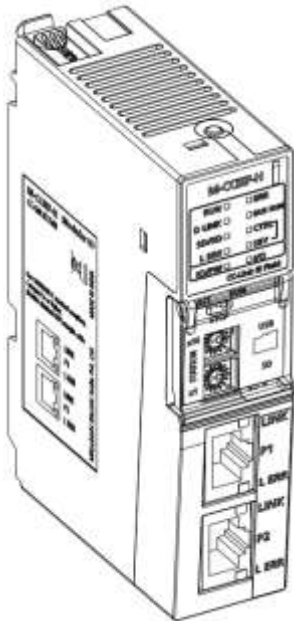

[Module Overview](#)

[Part Names](#)

[Specifications](#)

[Wiring](#)

[LED Indications](#)

[Setting of IP address / station number](#)

[Memory Mapping](#)

[Parameters](#)

[IO Data](#)

[Header Diagnostics](#)

Module Overview

M-CCIEF-H Header module is a remote station in a CC-Link IE TSN network.

NOTE

The header module "M-CCIEF-H" supports "CC-Link IE Field" and "CC-Link IE TSN" protocols. Protocol is user configurable. User can choose the protocol using the "Bus type" setting while creating project in the Modular IO Configurator tool.

Support for CC-Link IE TSN protocol is available for Header Version 1.1.0.0 and Modular IO Configurator tool Version 2.1.0.0;

Earlier versions (Header Version 1.0.0.0 and Modular IO Configurator tool Version 2.0.0.0) of the header module and the Modular IO Configurator support only "CC-Link IE Field."

Part Names

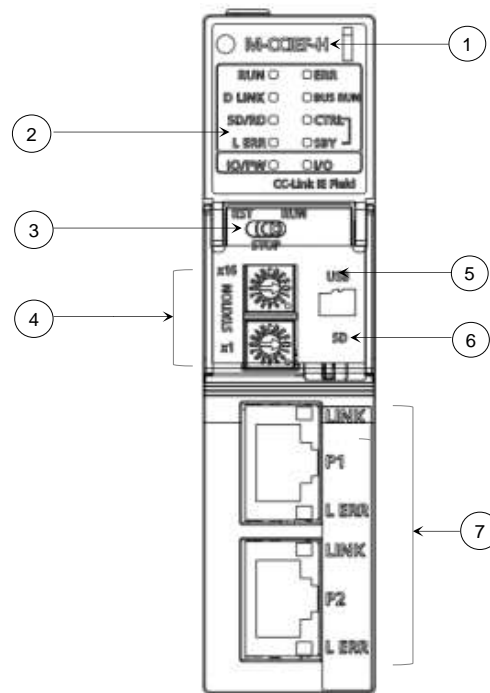

No.	Name	Description						
1	M-CCIEF-H	Module ordering code						
2	Module Indications	10 nos. of module level LED indications are provided as below, RUN, ERR, D LINK, BUS RUN, SD/RD, CTRL, L ERR, SBY, I/O and I/O PW.						
Front door is fixed to cover operation mode switch, rotary switch, USB port and SD memory card socket.								
3	Operation Mode Switch	3 - position toggle switch to set operation mode.						
		<table border="1"> <thead> <tr> <th>Switch position</th> <th>Functional details</th> </tr> </thead> <tbody> <tr> <td>RUN</td> <td>Sets header module to RUN mode. In RUN mode, the cyclic transmission is started between master station and header module.</td> </tr> <tr> <td>STOP</td> <td>Sets header module to STOP mode. When the module is in the STOP state, <ul style="list-style-type: none"> Digital outputs (RY) are turned off Analog outputs (RWw) are set to output 0 signal. </td> </tr> </tbody> </table>	Switch position	Functional details	RUN	Sets header module to RUN mode. In RUN mode, the cyclic transmission is started between master station and header module.	STOP	Sets header module to STOP mode. When the module is in the STOP state, <ul style="list-style-type: none"> Digital outputs (RY) are turned off Analog outputs (RWw) are set to output 0 signal.
		Switch position	Functional details					
RUN	Sets header module to RUN mode. In RUN mode, the cyclic transmission is started between master station and header module.							
STOP	Sets header module to STOP mode. When the module is in the STOP state, <ul style="list-style-type: none"> Digital outputs (RY) are turned off Analog outputs (RWw) are set to output 0 signal. 							

No.	Name	Description		
			Cyclic transmission with the master station is continues.	
		RESET	Resets header module. Hold switch at RESET position for a second.	
4	Rotary Switches for Station Number Setting	Sets the IP address Rotary switches x16 and x1 (hexadecimal). Refer section ' Setting of IP address / station number '		
5	USB Port (USB 2.0)	USB port used for configuration download and firmware download.		
6	SD Card socket	Not supported.		
7	Ethernet ports	P1 and P2	Port connectors for the connection of CC-Link IE TSN network. Connect an Ethernet cable.	
			L ERR LED	Indicates the port status.
			LINK LED	Indicates the link status.

Specifications

The table below provides technical specifications of **M-CCIEF-H**.

Specification		Description
Module Ordering Code		M-CCIEF-H
External Connections	Network Communication	RJ45 female- 2 nos.
	Configuration Port	USB 2.0
Fieldbus Support		CC-Link IE TSN
Maximum Number of Link Points Per Station	RX	1K points (1024 points, 128 bytes)
	RY	1K points (1024 points, 128 bytes)
	RWr	512 points (512 points, 1K bytes)
	RWw	512 points (512 points, 1K bytes)
Station Type		Remote station
Communication Speed		- 1 Gbps - 100 Mbps
CC-Link IE TSN Class		CC-Link IE TSN Class B, A
CC-Link IE TSN Protocol version		Protocol version 2.0
Network Topology		Line topology, star topology (coexistence of line topology and star topology is also possible), and ring topology
Communication Cable		- 1 Gbps - Ethernet cable which satisfies 1000BASE-T standard Category 5e or higher, straight cable (shielded, STP) - 100 Mbps - Ethernet cable which satisfies 100BASE-TX standard Category 5 or higher, straight cable (shielded, STP)
Maximum Station-to-Station Distance		100m
Number of I/O Points (Local memory)	IX	1K points (1024 points, 128 bytes)
	QX	1K points (1024 points, 128 bytes)
	IW	512 points (512 points, 1K bytes)
	QW	512 points (512 points, 1K bytes)
	SB	512 points (512 bytes)
Configurable Slots (on base module) ^{*1}		Header slot.
Internal Current Consumption (5 Vdc)		0.75A or less
Number of IO Modules		63 maximum (including system modules ^{*2})
Dimensions (H x W X D) mm		105 x 27 x 72
Weight (in grams)		130

^{*1} Mechanical coding on base module and back side of Header module ensures that M-APSU module cannot be fixed in Header slot as well as M-CCIEF-H module cannot be fixed in PSU slot.

^{*2} Digital and analog IO modules are intelligent modules and provide IO data and diagnostics to Header module. System modules are passive modules. So, Header module does not provide any information about system modules. Header module cannot detect presence of System modules in a modular IO station. So, System modules do not appear in the list after scan.

Wiring

The figure below shows M-CCIEF-H header wiring details. Wiring information is provided on left side wall of the module. Two Ethernet ports (P1 and P2) are provided on the front side of the module.

For common wiring recommendations, refer section [Wiring](#).

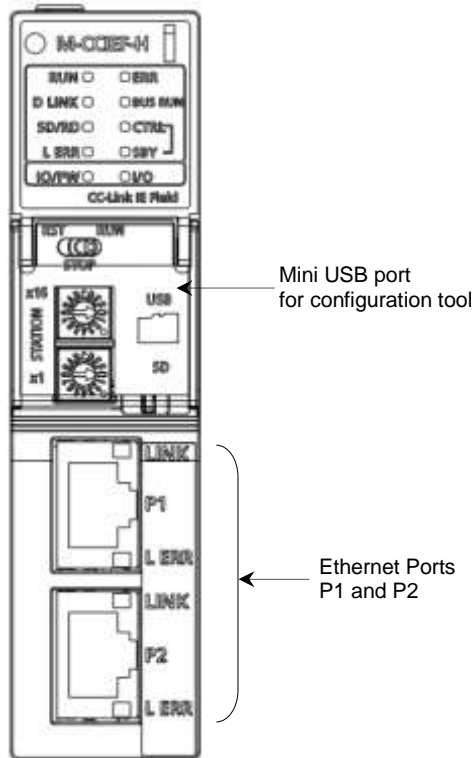

M-CCIEF-H: Wiring description

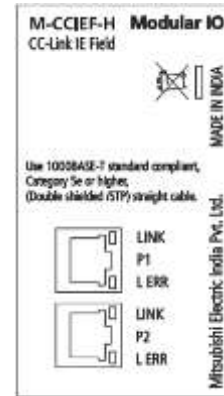

Connecting the Ethernet cable

4. Push the Ethernet cable connector into the port until it clicks. Pay attention to the connector's direction. Connector latch should be on right side.
5. Lightly pull it to check that it is securely connected.
6. Check whether the LINK LED of the port connected with an Ethernet cable is on.

NOTE

Both P1 connector and P2 connector can be used.

- When only one connector is used in star topology, either P1 connector or P2 connector is applicable.
- When two connectors are used in line topology and ring topology, the cable can be connected between P1 and P1, P2 and P2, or between P1 and P2 as shown below.

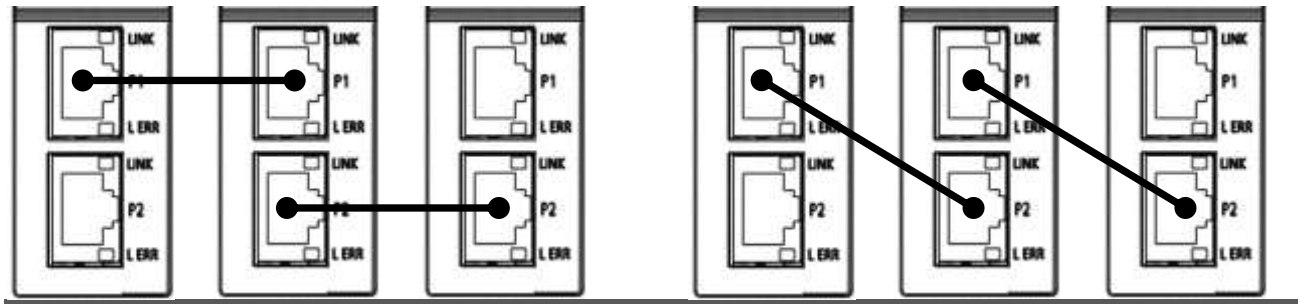

Disconnecting the Ethernet cable

1. Press the latch towards the left side and unplug the Ethernet cable.

Precautions

- Place the Ethernet cable in a duct or clamp them. If not, dangling cable may swing or inadvertently be pulled, resulting in damage to the module or cables or malfunction due to poor contact.
- Do not touch the core of the cable-side or module-side connector and protect it from dirt or dust. If oil from your hand, dirt or dust is attached to the core, it can increase transmission loss, arising a problem in data link.
- Check that the Ethernet cable is not disconnected or not shorted and there is no problem with the connector connection.
- Do not use Ethernet cables with broken latches. Doing so may cause the cable to become unplugged or malfunction.
- Hold the connector part when connecting and disconnecting the Ethernet cable. Pulling the cable connected to the module may result in damage to the module or cable or malfunction due to poor cable connection.
- The maximum station-to-station distance of the Ethernet cable is 100m. However, the length may be shorter depending on the operating environment of the cable. For details, contact your cable manufacturer.
- The bend radius of the Ethernet cable is limited. For details, check the specifications of the Ethernet cable to be used.

LED Indications

This section provides the meaning of LED indications on Header module.

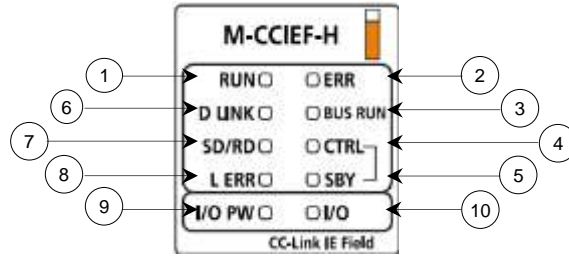

No.	LED	Colour	Status	Description
1	RUN	Green	--	* Refer table LED status explained in this section.
2	ERR	Red	--	
3	BUS RUN	Green	ON	Indicates header module is in RUN mode. In RUN mode, the cyclic transmission is started between master station and header module.
			OFF	Indicates header module is in STOP mode. The module switches to STOP mode due to following causes, - RUN/ STOP switch is set to STOP position. - Network master stations is in STOP state when connected. - Fatal error occurred at slave station.
4	CTRL	Green	-	Not used when configured for 'CC-Link IE TSN' bus type. LED remains OFF.
5	SBY	Green	-	Not used when configured for 'CC-Link IE TSN' bus type. LED remains OFF.
6	D LINK	Green	ON	Indicates cyclic transmission being performed.
			OFF	Indicates cyclic transmission is not performed (disconnection)
7	SD/ RD	Green	ON	Data transmission or reception is in progress.
			OFF	No data transmission or reception.
8	L ERR	Red	ON	Indicates abnormal data reception.
			OFF	Indicates normal data reception.
9	I/O PW	Green	ON	Field power is connected to I/O Adapter module fixed in Header assembly.
			OFF	Field power is not connected to IO Adapter module in Header assembly.

*For more details of LED indication states and flashing rates, refer section [Troubleshooting >> LED indications: States and flashing rates](#) in this manual.

10	I/O (Bi colour)	Blue Green	ON	Header module is communicating with attached IO module/s and no error is present.
		Red	ON	One of the following conditions occurred, <ul style="list-style-type: none"> - Invalid configuration detected. - No communication with I/O modules due to backplane bus fault - Backplane bus communication not started. - Header configuration download is in progress
			Single Flash	IO module mismatch detected for one or more IO slots.
			Double Flash	Communication error observed with one or more IO modules.
			Triple Flash	One of the following conditions occurred, <ul style="list-style-type: none"> - Fatal error (Except IO Module mismatch or communication error) is observed in one or more IO modules. - IO module related error is observed for one or more modules. This includes sensor wire break, no 24V detected by IO module, etc.
--	OFF	One of the following conditions occurred, <ul style="list-style-type: none"> - Header module is powered OFF. - Hardware failure error detected in header module. 		

Ethernet Ports (P1 and P2) ports are used for network connection as below,

Port P1	L ERR	Amber	ON	Indicates abnormal data reception.
			OFF	Indicates normal data reception.
	LINK	Green	ON	Link is up.
			OFF	Link is down.
Port P2	L ERR	Amber	ON	Indicates abnormal data reception.
			OFF	Indicates normal data reception.
	LINK	Green	ON	Link is up.
			OFF	Link is down.

*** LED Status**

LED status		Description
RUN	ERR	
ON	OFF	Normal operation
	ON	IO module level fatal error
	Blinking x1	Non-fatal error
Blinking x3	OFF	Reserved
	ON	
	Blinking x1	
Blinking x1	Blinking x2	Reserved
	ON	
	OFF	
OFF	ON	Header assembly module level fatal error
	Blinking x1	Initial processing

Setting of IP address / station number

The following two methods can be used to set IP address/ station number.

Using parameter + Rotary switch

In this method the first three octets are set using parameter 'IP address' and fourth octet of IP address is set using two rotary switches x1 and x16 (hexadecimal) provided on the front side of Header module.



For setting with rotary switches, make use of a flat head screwdriver with a tip width of 2.5 mm.

Set the station number between 1 to 254. Combination setting of x1 and x16 are as follows.

		x1 setting															
		0	1	2	3	4	5	6	7	8	9	A	B	C	D	E	F
x16 setting	0		1	2	3	4	5	6	7	8	9	10	11	12	13	14	15
	1	16	17	18	19	20	21	22	23	24	25	26	27	28	29	30	31
	2	32	33	34	35	36	37	38	39	40	41	42	43	44	45	46	47
	3	48	49	50	51	52	53	54	55	56	57	58	59	60	61	62	63
	4	64	65	66	67	68	69	70	71	72	73	74	75	76	77	78	79
	5	80	81	82	83	84	85	86	87	88	89	90	91	92	93	94	95
	6	96	97	98	99	100	101	102	103	104	105	106	107	108	109	110	111
	7	112	113	114	115	116	117	118	119	120	121	122	123	124	125	126	127
	8	128	129	130	131	132	133	134	135	136	137	138	139	140	141	142	143
	9	144	145	146	147	148	149	150	151	152	153	154	155	156	157	158	159
	A	160	161	162	163	164	165	166	167	168	169	170	171	172	173	174	175
	B	176	177	178	179	180	181	182	183	184	185	186	187	188	189	190	191
	C	192	193	194	195	196	197	198	199	200	201	202	203	204	205	206	207
	D	208	209	210	211	212	213	214	215	216	217	218	219	220	221	222	223
	E	224	225	226	227	228	229	230	231	232	233	234	235	236	237	238	239
	F	240	241	242	243	244	245	246	247	248	249	250	251	252	253	254	

To use this method, set parameter 'IP address setting' = Rotary switch.

Using parameter only

In this method, all four octets of IP address are set using parameter 'IP address'. To use this method, set parameter 'IP address setting' = Parameter. In this case, setting of rotary switches 'x1' and 'x16' is ignored.

Refer section '[Parameters](#)' for more details.

NOTE

- Rotary switch setting is detected at power on only. So, set the rotary switch when header module is powered off.
Non-fatal error (2008H) is declared if rotary switch is changed while power is ON.
- Rotary switch setting 0 and 255 are invalid. Header will declare fatal error (1013H).

Memory mapping

Local memory is mapped to header module and link devices at master station as shown below.

Memory Area	Local Address	Access	Master Station
Input bit	IX	Read	RX
Input word	IW	Read	RWr
Output bit	QX	Write	RY
Output word	QW	Write	RWw
Status byte	SB	Read	RWr

NOTE

SB memory is shared with network master if "Share SB to RWr" parameter is set as Enable'.
Both IW and SB memories are mapped to RWr memory. IW memory is mapped first, followed by SB memory.

Parameters

Configure modular IO station with header assembly as explained in section ‘[Configure Modular IO station with Header Assembly](#)’.

Set the following parameters using Modular IO Configuration tool.

Parameter Name	Project Value	Comment
General parameters		
Action on fatal error	Continue N/W communication [Default]	Defines action on fatal error. Stop or continue communication with network master.
	Stop N/W communication	
Share SB to RWr	Disable [Default]	Enables diagnostic data (SB) sharing with network master
	Enable	
Output hold/ clear	Clear [Default]	Defines output state of IO modules when disconnected from network or master CPU is not in RUN mode.
	Hold	
Share diagnostics	Enable [Default]	Enables diagnostic data (SB) updation.
	Disable	
Network parameters		
IP address setting	Rotary switch [Default]	Defines IP address setting method.
	Parameter	
IP address	192.168.15.1 [Default]	Header IP address
Subnet mask	255.255.255.0 [Default]	Subnet mask
Remote reset enable	Disable [Default]	Defines remote reset is enable / disabled.
	Enable	
CC Link IE TSN Type	Class B [Default]	Defines CC-Link IE TSN certification class.
	Class A	
CC Link IE TSN Speed	1Gbps [Default]	Defines communication speed.
	100Mbps	

IO Data

Monitor following diagnostics in SB memory.

Diagnostic summary	Data Type	Local Address*	Bit Status	Description
Hardware failure	BOOL	SB 0.0	TRUE	Becomes TRUE, if hardware error of Header module occurs.
			FALSE	
Configuration error	BOOL	SB 0.1	TRUE	Becomes TRUE, if invalid configuration data is downloaded in Header module.
			FALSE	
Header assembly fatal error	BOOL	SB 0.2	TRUE	Becomes TRUE, in case of fatal error detected in header assembly. Refer section ' List of station Error Codes '.
			FALSE	
Header assembly non-fatal error	BOOL	SB 0.3	TRUE	Becomes TRUE, in case of non-fatal error detected in header assembly. Refer section ' List of station Error Codes '.
			FALSE	
IO module mismatch error	BOOL	SB 0.4	TRUE	Becomes TRUE, if IO module configured in slot is different than the physically present IO module.
			FALSE	
IO module COM error	BOOL	SB 0.5	TRUE	Becomes TRUE, if data exchange between Header and one or more IO modules is stopped after successful data exchange.
			FALSE	
IO module fatal error	BOOL	SB 0.6	TRUE	Becomes TRUE, in case of fatal error detected for one or more IO modules. Refer section ' List of station Error Codes '.
			FALSE	
IO module non-fatal error	BOOL	SB 0.7	TRUE	Becomes TRUE, in case of non-fatal error detected for one or more IO modules. Refer section ' List of station Error Codes '.
			FALSE	
Additional IO modules detected	BOOL	SB 1.0	TRUE	Becomes TRUE, if Header module detects additional IO modules (other than configured one) at modular IO station.
			FALSE	
Backplane bus fault	BOOL	SB 1.1	TRUE	Becomes TRUE, if backplane bus fault is detected.
			FALSE	
PSU error detected (P1/P2)	BOOL	SB 1.2	TRUE	Becomes TRUE, if power supply module related error is detected.
			FALSE	
Reserved	BOOL	SB 1.3	--	--
Reserved	BOOL	SB 1.4	--	--
Bus stopped	BOOL	SB 1.5	TRUE	Becomes TRUE, if fieldbus communication is stopped.
			FALSE	
FW error	BOOL	SB 1.6	TRUE	Becomes TRUE, if firmware watchdog error is detected.
			FALSE	
No field power supply	BOOL	SB 1.7	TRUE	Becomes TRUE, if field power supply is not detected.
			FALSE	

User can monitor slot status.

Slot status	Data Type	Local Address*	Bit Status	Description
Slot status 0..7				
Slot 0	BOOL	SB 2.0	TRUE	Header module (or header assembly) is healthy.
			FALSE	Error is detected for Header module (or header assembly).
Slot 1	BOOL	SB 2.1	TRUE	I/O module is configured in slot 1 and is healthy.
			FALSE	I/O module in slot 1 has error or I/O module is not configured in slot 1.
⋮	⋮	⋮	⋮	
Slot 7	BOOL	SB 2.7	TRUE	I/O module is configured in slot 7 and is healthy.
			FALSE	I/O module in slot 7 has error or I/O module is not configured in slot 7.
Slot status 8..15				
Slot 8	BOOL	SB 3.0	TRUE	I/O module is configured in slot 8 and is healthy.
			FALSE	I/O module in slot 8 has error or I/O module is not configured in slot 8.
⋮	⋮	⋮	⋮	
Slot 15	BOOL	SB 3.7	TRUE	I/O module is configured in slot 15 and is healthy.
			FALSE	I/O module in slot 15 has error or I/O module is not configured in slot 15.
⋮	⋮	⋮	⋮	
Slot status 56..63				
Slot 56	BOOL	SB 9.0	TRUE	I/O module is configured in slot 56 and is healthy.
			FALSE	I/O module in slot 56 has error or I/O module is not configured in slot 56.
⋮	⋮	⋮	⋮	
Slot 63	BOOL	SB 9.7	TRUE	I/O module is configured in slot 63 and is healthy.
			FALSE	I/O module in slot 63 has error or I/O module is not configured in slot 63.

Also, refer section '[List of Station Error Codes](#)' for details of Error codes displayed in Modular IO configurator tool.

Header diagnostics:

Detailed diagnostics of header module (Header diagnostics) can be monitored in Modular IO Configurator tool. Refer section '[Header diagnostics and slot diagnostics](#)' for more details.

For M-CCIEF-H, the following status and diagnostic information is available

Diagnostics	Description
Identification	
Vendor code	Vendor code of manufacturer.
Ordering code	Ordering code of header module. M-CCIEF-H : For CC-Link IE Field Header module
Version Info	
Device version	Device version of header module.
Hardware version	Hardware version of header module.
Firmware version	Firmware version of header module.
Backplane bus version	Backplane bus version of header module.
Fieldbus version	Fieldbus stack version of header module.
Hardware	
EEPROM checksum	EEPROM checksum.
Self-diagnostic test	Bitwise status of self-tests at start up.
ROM test	Result of ROM test (0: No error, 1: Error)
RAM test	Result of RAM test (0: No error, 1: Error)
Reserved	.—
EEPROM test	Result of EEPROM test (0: No error, 1: Error)
MAC ID test	Result of MAC ID test (0: No error, 1: Error)
Switch setting value (x1)	Status of rotary switch x1.
Switch setting value (x16)	Status of rotary switch x16.
Switch setting value RUN/STOP switch	Status of RUN/ STOP switch. 0: STOP, 1: RUN, 2: RESET
LED status1	LED allocation: 16#HGFEDCBA A: RUN, B: ERR, C: BUS RUN, D: D-LINK, E: CTRL, F: SD/RD, H: L ERR LED status- 0: OFF, 1: ON, 2: Blink slow, 4: Blink fast, 5: Single flash, 6: Double flash, 7: Triple flash
LED status2	LED allocation: 16#HGFEDCBA A: I/O PWR, B: I/O RED, C: I/O GREEN LED status- 0: OFF, 1: ON, 2: Blink slow, 4: Blink fast, 5: Single flash, 6: Double flash, 7: Triple flash
Memory size	
IX	Configured size of bit input image (IX) No. of bytes
IW	Configured size of word input image (IW).No. of bytes
QX	Configured size of bit output image (QX). No. of bytes
QW	Configured size of word output image (QW) No. of bytes
SB	Configured size of diagnostic (SB) image No. of bytes
Header scan time	
Current	Header scan time.
Maximum	Maximum header scan time.

Minimum	Minimum header scan time.
MIO station diagnostics summary	
No. of configured slots	No. of configured slots.
No. of detected slots	No. of detected slots.
Header status summary	Bitwise status of header module.
Hardware failure	Hardware failure detected. Check self-diagnostic test results.
Configuration error	Invalid configuration detected for header.
IO module mismatch	Module absent or different module present in one or more slots.
IO module COM error	Module communication error detected during runtime.
Slot fatal error	Fatal error detected for one or more slots.
Slot non-fatal error	Non-fatal error detected for one or more slots.
Additional IO modules detected	Number of IO modules detected are more than number of IO modules configured.
No field power supply	No field power supply detected.
P1 power supply healthy	P1 power supply healthy.
P2 power supply healthy	P2 power supply healthy.
IO adapter module detected	IO adapter module detected.
Header 1 detected	Header 1 detected.
Header assembly fatal error	Header assembly fatal error detected.
Header assembly non-fatal error	Header assembly non-fatal error detected.
Slots 0-15	
Configured	Bitwise module configuration status.
Healthy	Bitwise module health status.
IO error	Bitwise status of module mismatch or absent.
COM error	Bitwise status of COM error after power ON
Fatal error	Bitwise status of module fatal error.
Non-fatal error	Bitwise status of module non-fatal error
Slots 48-63	
Detected	Bitwise module detection status.
Healthy	Bitwise module health status.
IO error	Bitwise status of module mismatch or absent.
COM error	Bitwise status of COM error after power ON
Fatal error	Bitwise (slotwise) status of module fatal error.
Non-fatal error	Bitwise status of module non-fatal error
Interface(ETH1)	
Link status	Indicates the link status. 1: Link up, 0: Link down
Port status	Indicates the port status. 1: Abnormal data received, 0: Normal data received.
Cable disconnection detection count	Number of cable disconnection detected since power ON/ reset.
Interface(ETH2)	
Link status	Indicates the link status. 1: Link up, 0: Link down
Port status	Indicates the port status. 1: Abnormal data received, 0: Normal data received.
Cable disconnection detection count	Number of cable disconnection detected since power ON/ reset.
CC-Link IE TSN	
Data link status of own station	00: Cyclic transfer in progress, 02:Cyclic transfer stopped, 03: No data link

Cause of communication interruption	00: Normal communication or power on, 30h: Cable disconnection 33h: Disconnection of return in process
Cause of data link stop	00H: Normal, 01H: Stop direction, 02H: Monitoring time timeout 10H: Parameter not received, 11H: rotary switch setting out of range, 12H: Reserved station 13H: Station no./IP address duplication, 18H: Parameter error 19H: Parameter comm.in progress, 1AH: Station type mismatch 1BH: Parameer mismatch, 20H: Fatal error.
Module status of own station	01H: STOP (normal), 02H: STOP (FATAL error), 03H: RUN (Fatal error) 04H: RUN (normal), 05H: RUN (Non-fatal error), 0FH: Initial processing
Connection status of own station	00H: Normal (P1-OK, P2-OK), 01H: Normal (P1-OK, P2-NoCable) 04H: Normal (P1-LpBk, P2-NoCable), 10H: (P1: NoCable, P2-Normal) 11H: Disconnecting (P1, P2: NpCable), 12H: Disconnecting (P1:NoCable, P2-Init) 21H: Disconnecting (Init, NoCable), 22H: Disconnecting (P1, P2: Init) 40H: Normal (P1:NoCable, P2:LpBk)
Master station CPU status	Bitwise status of master CPU operation
Run/stop status	Run/stop status (0: RUN, 1: STOP)
Error status of master	Error status of master(0: No error, 1: Error)
No. of transient requests received	Number of transient requests received
No. of transient requests error	Number of transient requests error
No. of cyclic transmission requests received	No. of cyclic transmission requests received.
IP address	IP address set in device
Redundant power supply system^[1]	
Power supply status summary	Power supply status summary bitwise
P1 – AC/DC DOWN detected	P1 power supply status (0: No AC/DC down, 1: AC/DC down)
P1 – Power-off/power supply voltage drop detected	P1 power supply status (0: No input power supply voltage drop detected, 1: Input power supply voltage drop detected)
P1 – Power supply failure detection	P1 power supply status (0:No failure detected, 1:PSU failure detected)
P2 – AC/DC DOWN detected	P2 power supply status (0: No AC/DC down, 1: AC/DC down)
P2 – Power-off/power supply voltage drop detected	P2 power supply status (0: No input power supply voltage drop detected, 1: Input power supply voltage drop detected)
P2 – Power supply failure detection	P2 power supply status (0: No failure detected, 1: PSU failure detected)
Number of AC/DC down detections (P1)	Number of AC/DC down detections (P1)
Number of AC/DC down detections (P2)	Number of AC/DC down detections (P2)

^[1] P2 power supply status is only applicable for configurations with M-B5 base module and power supply module is inserted in P2 slot.

5.6 Special Features

[Configuration Transfer with SDHC Memory Card](#)

Configuration Transfer with SDHC Memory Card

Header supports configuration file transfer to/from SD card. This function is useful to store configuration file backup and copy to other Header modules. Configuration copy to/from SD card is possible at power ON only.

SD card specifications are as below.

Specification	Description
Type	Micro SD
SD Card Standard	SDHC
Speed Class Supported	Class 4 (4MB/S) , Class 10 (10MB/S)
Supported Memory Capacity	4GB to 32GB
File System	FAT32
SD card Dimensions	11 x 15 x 1.0 mm
Recommended make of SD Card	Transcend, Scandisk, SAMSUNG

The table below explains conditions and actions performed during configuration copy.

Sr. No.	Condition		Visual Indication on Header module		Actions Performed
	File Copy from	Description	RUN LED ^{*1}	I/O LED	
1	SD Card to Header [Pushbutton on Header is not kept pressed at power ON]	SD card is formatted with FAT32 file format. Valid configuration file (MIOcnfg.bin) is stored at root directory on SD memory card.	Green : Blinking	Yellow : Blinking	Configuration file is copied
		SD card is formatted with FAT32 file format. Configuration file (MIOcnfg.bin) at root directory on SD memory card and configuration file in connected Header are identical .			Configuration file is not copied
		SD card is formatted with Non-FAT32 file format or formatting is invalid.		Red : Single flash	Header continues with normal execution after 15 secs duration.
		SD card is formatted with FAT32 file format. Configuration file (MIOcnfg.bin) is absent at root directory on SD memory card.		Red : Double flash	
		SD card is formatted with FAT32 file format. Invalid configuration file (MIOcnfg.bin) for file with size more than 192 Kbytes is stored at root directory on SD memory card.			
		Header types are mismatch. Header type in Configuration file (MIOcnfg.bin) is not matching with connected Header type.			
2	Configuration file is successfully transferred from SD Card to Header	Green : Continuous ON	Green : Continuous ON	MIOcnfg.bin file gets transferred from SD card to Header.	

3	Header to SD Card [Pushbutton on Header is kept pressed at power ON]	SD card is formatted with Non-FAT32 file format or formatting is invalid..	Green : Blinking	Red : Single flash	-
		SD card is formatted with FAT32 file format and configuration file MIOcnfg.bin is absent		Green : Continuous ON	MIOcnfg.bin is generated at root directory on SD memory card.
		SD card is formatted with FAT32 file format and configuration file MIOcnfg.bin is present at root directory		Green : Continuous ON	MIOcnfg.bin is overwritten at root directory on SD memory card.
4		Configuration file transfer from Header to SD card is in progress		OFF	-
5		Configuration file is successfully transferred from Header to SD card	Green : Continuous ON	Green : Continuous ON	MIOcnfg.bin file gets transferred from Header to SD card.

*1 For M-EIP-H Header, MS (Module Status) LED is applicable.

NOTE

Only one configuration file i.e. "MIOcnfg.bin" can be stored in SD memory card at a time.

SD card functionality is supported for Modular IO Configurator Tool [V1.4.0.0] and Header (M-CCB-H and M-MT-H) firmware [V01.02.00.00], Header (M-EIP-H) firmware [V01.01.00.00] and onwards.

[Back To Index Page](#)

6 Digital IO Modules









Digital IO Modules: Overview	
24 VDC Digital Input Sink Type (Negative Common) Module	M-4D
	M-8D
	M-16D
24 VDC Digital Input Source Type (Positive Common) Module	M-4DE
	M-8DE
	M-16DE
24 VDC Transistor Output Source Type Module	M-4TE
	M-8TE
	M-16TE

Overview

Digital input module accepts 24 VDC inputs from various input devices like push buttons, limit switches and proximity switches. It can be used for sink or source type of interface.

Digital output module provides 24 VDC type of output through solid-state type of devices in order to switch on off various field elements like relays, contactors, lamps and solenoid valves, etc. Source type of digital output modules are available.

In modular IO station, different types of digital IO modules are available as below,

Ordering Information	Ordering Code	Colour Identification*
Digital Input		
4 Point 24 VDC Digital Input Sink Module	M-4D	
8 Point 24 VDC Digital Input Sink Module	M-8D	
16 Point 24 VDC Digital Input Sink Module	M-16D	
4 Point 24 VDC Digital Input Source Module	M-4DE	
8 Point 24 VDC Digital Input Source Module	M-8DE	
16 Point 24 VDC Digital Input Source Module	M-16DE	
Digital Output		
4 Point 24 VDC Digital Output Source Module	M-4TE	
8 Point 24 VDC Digital Output Source Module	M-8TE	
16 Point 24 VDC Digital Output Source Module	M-16TE	

*Color code is provided on LED label and at bottom side of terminal block. User should always ensure that color code of LED label and terminal block is identical.

6.1 M-4D

[4 Point 24 VDC Digital Input Sink Type
(Negative Common) Module]

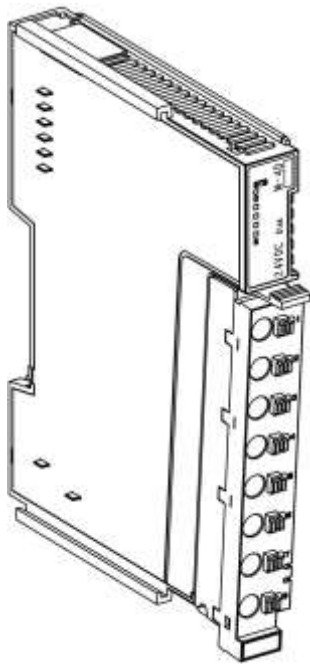

[Module Overview](#)

[Part Names](#)

[Specifications](#)

[LED Indications](#)

[Connection Diagram](#)

[Parameters](#)

[IO Data](#)

Module Overview

M-4D is 4 point 24 VDC digital input module. It allows sink type (negative common) of connections for all the inputs. The module can be fixed in any IO slot of modular IO station.

Part Names

The figure below describes part names of the module.

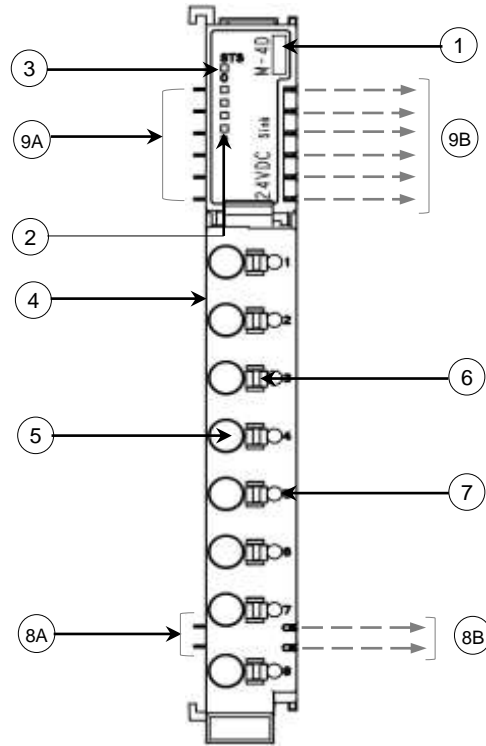

No.	Name	Description
1	M-4D	Module ordering code
2	IO LED Indications	0 to 3: 4 Green colour LEDs for individual input status
3	Module LED Indication	STS: 1 Bi-colour LED for module status
4	Terminal Block	8-point removable push type
5	IO Point	Wire insertion point for IO terminal
6	Push Button	Press to release wire
7	Test Point	To measure signal voltage
8A	Field Power Supply Interface	2 Incoming pins for field power supply interface
8B		2 Outgoing pins for field power supply interface
9A	System Power Supply Interface	6 Incoming pins for system power supply interface
9B		6 Outgoing pins for system power supply interface

Specifications

The table below provides technical specifications of **M-4D**.

Specification		Description
Ordering Code		M-4D
Number of Inputs		4
Input Type		Sink type (Negative common)
Voltage Rating		24 VDC (18 to 30 VDC including ripple)
Input Current		6 mA typical at 24 VDC
ON Voltage / ON Current		18 VDC or higher / 4.0 mA or higher
OFF Voltage / OFF Current		8 VDC or lower / 1.8 mA or lower
Transition Delay		3 ms to 70 ms [10 ms, Default]
Input Impedance		5.2 K Ω
Isolation		Between input and internal circuit Optical 1.5 KV
		Between inputs No isolation
IO Memory Consumption	Input Bits (IX)	4 points (1 byte)
	Diagnostics (SB) [User configurable]	1 byte
System Power Supply Consumption		40 mA
Field Power Supply Consumption		Number of inputs simultaneously ON X 6 mA
Terminal Block (Removable push type)		8 point
Recommended Wire Size*		0.5 sq. mm to 2.0 sq. mm (AWG 20 to 14), Solid wire or Stranded (flexible) wire with lugs
Module Dimensions (H x W x D) in mm		105 x 13.2 x 83

*Refer section [Wiring](#) for more details.

LED Indications

This section provides meaning of LED indications available on module.

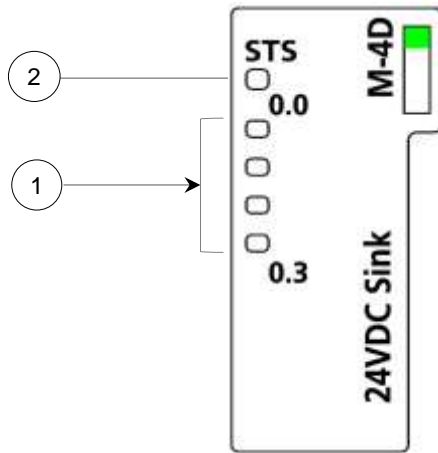

No.	*LED	Colour	Status	Description	
1	0.0 to 0.3	Green	ON	Input is ON	
			OFF	Input is OFF	
2	STS	Bi-colour LED	None	Module is powered OFF.	
			Blue Green	ON	Module is powered ON and communicating with Header module
				Single flash	Communication with Header is not established due to, <ul style="list-style-type: none"> - Module is powered ON and waiting for communication from Header. - Module mismatch
			Red	ON	Hardware failure is detected on module.
				Single flash	One of the following condition occurred. <ul style="list-style-type: none"> - No communication from Header - Backplane bus fault detected.
Yellow	ON	24 VDC field power supply is not available			

*For more details of LED indication states and flashing rates, refer section [Troubleshooting >> LED indications: States and flashing rates](#) in this manual.

Connection Diagram

The figure shows module front with 8 point terminal block, alongwith interface of field input devices like push buttons, limit switches and proximity switches for sink operation i.e. with negative common.

Wiring description is provided on right side wall of the module.

For common wiring recommendations, refer section [Wiring](#).

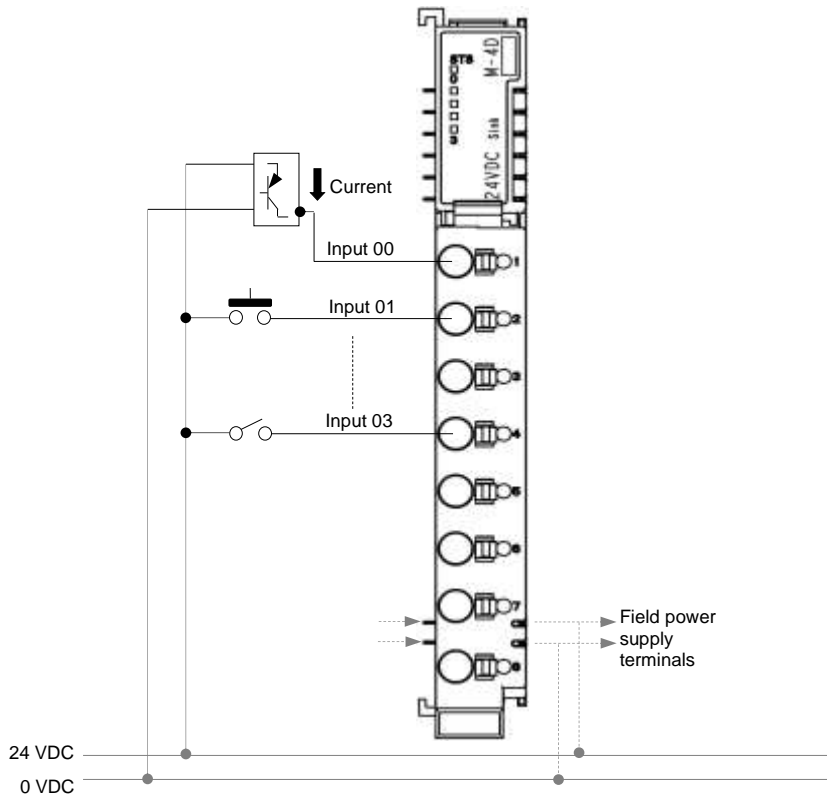

M-4D: Wiring description

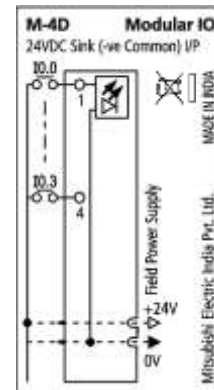

NOTE

24 VDC supply shown here and Field power supply connected to Header module (terminal numbers 5, 6 and 7, 8) should be same. Alternately, ensure that grounds (0V) are common if supply sources are different,

Some of the input devices like proximity switches may malfunction due to inherent off state leakage current. Ensure that proper bleeder resistor is connected as a load considering maximum specified OFF state current of input module.

Parameters

Serial communication module can be configured in modular IO station using Modular IO Configurator. For addition and removal of module, refer section [Modular IO Configurator](#).

User can set the following module parameters

Parameter Name	Project Value	Comment
Share diagnostics	Enable	Enables diagnostic data (SB) sharing with header
	Disable [Default]	
Input Filter Time (ms)	10 (Default)	Defines input filter time in ms.

Module diagnostic data is available in Status Byte (SB) memory, if module parameter "Share diagnostics" is set to Enable.

IO Data

The table below provides description of Input data for CH0 and CH1.

Channel	Data Type	Local Address*
Input Data CH0		
Digital Input 00-03	BYTE	IX n
DI 00	BOOL	IX n.0
⋮	⋮	⋮
DI 03	BOOL	IX n.3

*Local address n changes as per the slot position of IO module and configuration of modular IO station.

User can monitor the following diagnostics.

Module Diagnostics	Data Type	Local Address*	Bit Status	Description
No field power Supply	BOOL	SB n.0	TRUE	24VDC field power supply is not available
			FALSE	24VDC field power supply is available
Reserved	BOOL	SB n.1 to SB n.7	Reserved	Reserved

Module diagnostic data is available in Status Byte (SB) memory, if module parameter "Share diagnostics" is set to Enable.

Refer section [Troubleshooting](#) for station error code list and error messages.

6.2 M-8D

[8 Point 24 VDC Digital Input Sink Type
(Negative Common) Module]

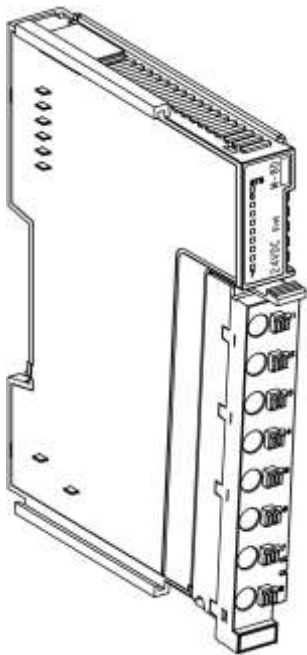

[Module Overview](#)

[Part Names](#)

[Specifications](#)

[LED Indications](#)

[Connection Diagram](#)

[Parameters](#)

[IO Data](#)

Module Overview

M-8D is 8 point 24 VDC digital input module. It allows sink type (negative common) of connections for all the inputs. The module can be fixed in any IO slot of modular IO station.

Part Names

The figure below describes part names of the module.

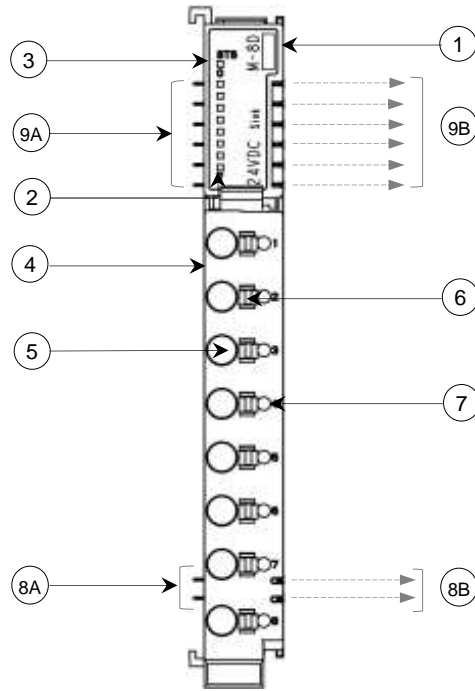

No.	Name	Description
1	M-8D	Module ordering code
2	IO LED Indications	0 to 7: 8 Green colour LEDs for individual input status
3	Module LED Indication	STS: 1 Bi-colour LED for module status
4	Terminal Block	8-point removable push type
5	IO Point	Wire insertion point for IO terminal
6	Push Button	Press to release wire
7	Test Point	To measure signal voltage
8A	Field Power Supply Interface	2 Incoming pins for field power supply interface
8B		2 Outgoing pins for field power supply interface
9A	System Power Supply Interface	6 Incoming pins for system power supply interface
9B		6 Outgoing pins for system power supply interface

Specifications

The table below provides technical specifications of **M-8D**.

Specification		Description	
Ordering Code		M-8D	
Number of Inputs		8	
Input Type		Sink type (Negative common)	
Voltage Rating		24 VDC (18 to 30 VDC including ripple)	
Input Current		6 mA typical at 24 VDC	
ON Voltage / ON Current		18 VDC or higher / 4.0 mA or higher	
OFF Voltage / OFF Current		8 VDC or lower / 1.8 mA or lower	
Transition Delay		3 ms to 70 ms [10 ms, Default]	
Input Impedance		5.2 K Ω	
Isolation		Between input and internal circuit	Optical 1.5 KV
		Between inputs	No isolation
IO Memory Consumption	Input Bits (IX)	8 points (1 byte)	
	Diagnostics (SB) [User configurable]	1 byte	
System Power Supply Consumption		45 mA	
Field Power Supply Consumption		Number of inputs simultaneously ON X 6 mA	
Terminal Block (Removable push type)		8 point	
Recommended Wire Size*		0.5 sq. mm to 2.0 sq. mm (AWG 20 to 14), Solid wire or Stranded (flexible) wire with lugs	
Module Dimensions (H x W x D) in mm		105 x 13.2 x 83	

*Refer section [Wiring](#) for more details.

LED Indications

This section provides meaning of LED indications available on module.

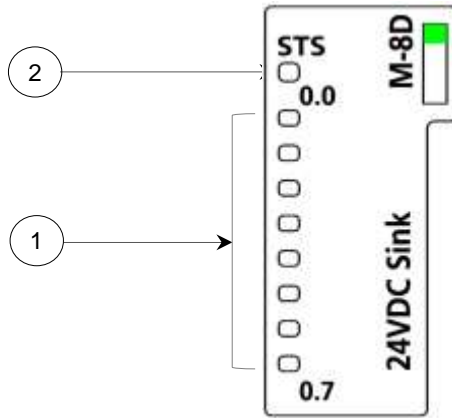

No.	*LED	Colour	Status	Description	
1	0.0 to 0.7	Green	ON	Input is ON	
			OFF	Input is OFF	
2	STS	Bi-colour LED	None	Module is powered OFF.	
			Blue Green	ON	Module is powered ON and communicating with Header module
				Single flash	Communication with Header is not established due to, <ul style="list-style-type: none"> - Module is powered ON and waiting for communication from Header. - Module mismatch
			Red	ON	Hardware failure is detected on module.
				Single flash	One of the following condition occurred. <ul style="list-style-type: none"> - No communication from Header - Backplane bus fault detected.
Yellow	ON	24VDC field power supply is not available			

*For more details of LED indication states and flashing rates, refer section [Troubleshooting >> LED indications: States and flashing rates](#) in this manual.

Connection Diagram

The figure shows module front with 8-point terminal block, alongwith interface of field input devices like push buttons, limit switches and proximity switches for sink operation i.e. with negative common.

Wiring description is provided on right side wall of the module.

For common wiring recommendations, refer section [Wiring](#).

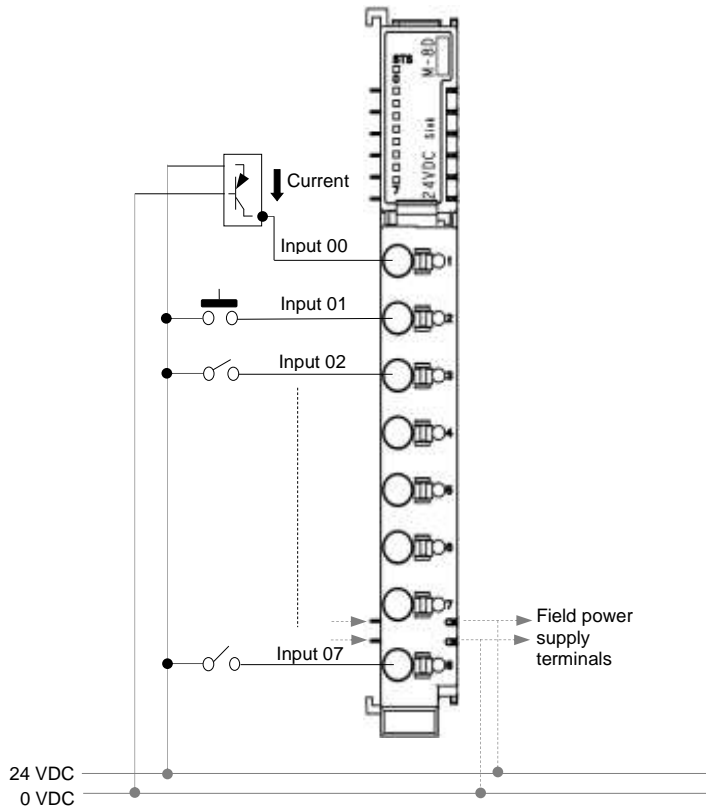

M-8D: Wiring description

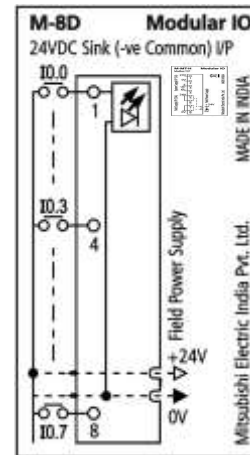

NOTE

24 VDC supply shown here and Field power supply connected to Header module (terminal numbers 5, 6 and 7, 8) should be same. Alternately, ensure that grounds (0V) are common if supply sources are different,

Some of the input devices like proximity switches may malfunction due to inherent off state leakage current. Ensure that proper bleeder resistor is connected as a load considering maximum specified OFF state current of input module.

Parameters

IO module can be configured in modular IO station using Modular IO Configurator. For addition and removal of IO module, refer section [Modular IO Configurator](#).

User can set the following module parameters

Parameter Name	Project Value	Comment
Share diagnostics	Enable	Enables diagnostic data (SB) sharing with header
	Disable [Default]	
Input Filter Time (ms)	10 (Default)	Defines input filter time in ms (Supported range : 3 to 70 msec).

Module diagnostic data is available in Status Byte (SB) memory, if module parameter "Share diagnostics" is set to Enable.

IO Data

The table below provides description of Digital input.

Channel	Data Type	Local Address*
Digital Input		
Digital Input 00-07	BYTE	IX n
DI 00	BOOL	IX n.0
⋮	⋮	⋮
DI 07	BOOL	IX n.7

*Local address n changes as per the slot position of IO module and configuration of modular IO station.

User can monitor the following diagnostics

Module Diagnostics	Data Type	Local Address*	Bit Status	Description
No field power Supply	BOOL	SB n.0	TRUE	24VDC field power supply is not available
			FALSE	24VDC field power supply is available
Reserved	BOOL	SB n.1 to SB n.7	Reserved	Reserved

Module diagnostic data is available in Status Byte (SB) memory, if module parameter "Share diagnostics" is set to Enable.

Refer section [Troubleshooting](#) for station error code list and error messages.

6.3 M-16D

[16 Point 24 VDC Digital Input Sink Type
(Negative Common) Module]

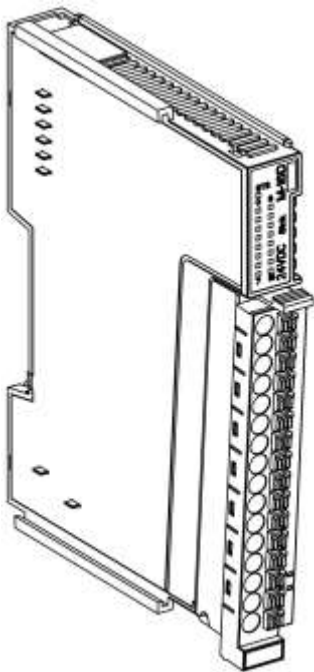

[Module Overview](#)

[Part Names](#)

[Specifications](#)

[LED Indications](#)

[Connection Diagram](#)

[Parameters](#)

[IO Data](#)

Module Overview

M-16D is 16 point 24 VDC digital input module. It allows sink type (negative common) of connections for all the inputs. The module can be fixed in any IO slot of modular IO station.

Part Names

The figure below describes part names of the module.

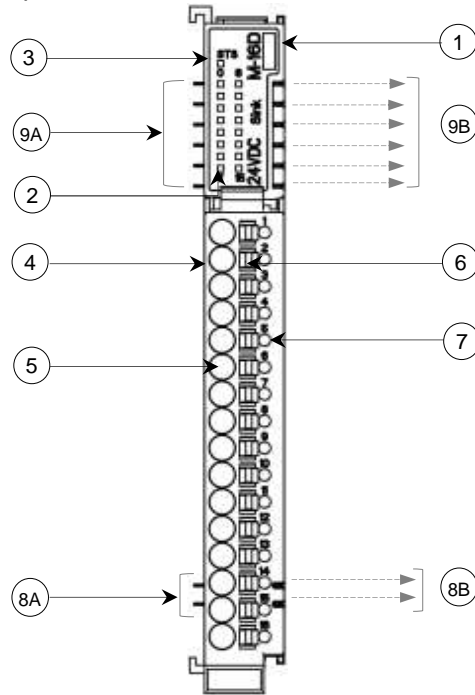

No.	Name	Description
1	M-16D	Module ordering code
2	IO LED Indications	0 to 15: 16 Green colour LEDs for individual input status
3	Module LED Indication	STS: 1 Bi-colour LED for module status
4	Terminal Block	16-point removable push type
5	IO Point	Wire insertion point for IO terminal
6	Push Button	Press to release wire
7	Test Point	To measure signal voltage
8A	Field Power Supply Interface	2 Incoming pins for field power supply interface
8B		2 Outgoing pins for field power supply interface
9A	System Power Supply Interface	6 Incoming pins for system power supply interface
9B		6 Outgoing pins for system power supply interface

Specifications

The table below provides technical specifications of **M-16D**.

Specification		Description
Ordering Code		M-16D
Number of Inputs		16
Input Type		Sink type (Negative common)
Voltage Rating		24 VDC (18 to 30 VDC including ripple)
Input Current		6 mA typical at 24 VDC
ON Voltage / ON Current		18 VDC or higher / 4.0 mA or higher
OFF Voltage / OFF Current		8 VDC or lower / 1.8 mA or lower
Transition Delay		3 ms to 70 ms [10 ms, Default]
Input Impedance		5.2 K Ω
Isolation		Between input and internal circuit
		Optical 1.5 KV
IO Memory Consumption		Between inputs
		No isolation
Input Bits (IX)	Input Bits (IX)	16 points (2 bytes)
	Diagnostics (SB) [User configurable]	1 byte
System Power Supply Consumption		65 mA
Field Power Supply Consumption		Number of inputs simultaneously ON X 6 mA
Terminal Block (Removable push type)		16 point
Recommended Wire Size*		0.5 to 1.0 sq. mm (AWG 20 to 16) Solid wire or Stranded (flexible) wire with lugs
Module Dimensions (H x W x D) in mm		105 x 13.2 x 83

*Refer section [Wiring](#) for more details.

LED Indications

This section provides meaning of LED indications available on module.

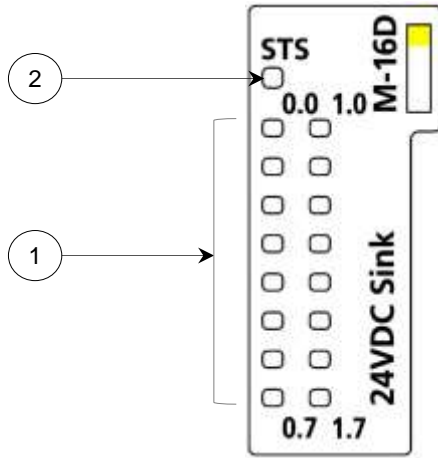

No.	*LED	Colour	Status	Description	
1	0.0 to 0.7, 1.0 to 1.7	Green	ON	Input is ON	
			OFF	Input is OFF	
2	STS	Bi-colour LED	None	Module is powered OFF.	
			Blue Green	ON	Module is powered ON and communicating with Header module
				Single flash	Communication with Header is not established due to, <ul style="list-style-type: none"> - Module is powered ON and waiting for communication from Header. - Module mismatch
			Red	ON	Hardware failure is detected on module.
				Single flash	One of the following condition occurred. <ul style="list-style-type: none"> - No communication from Header - Backplane bus fault detected.
Yellow	ON	24VDC field power supply is not available			

*For more details of LED indication states and flashing rates, refer section [Troubleshooting >> LED indications: States and flashing rates](#) in this manual.

Connection Diagram

The figure shows module front with 16 point terminal block, alongwith interface of field input devices like push buttons, limit switches and proximity switches for sink operation i.e. with negative common.

Wiring description is provided on right side wall of the module.

For common wiring recommendations, refer section [Wiring](#).

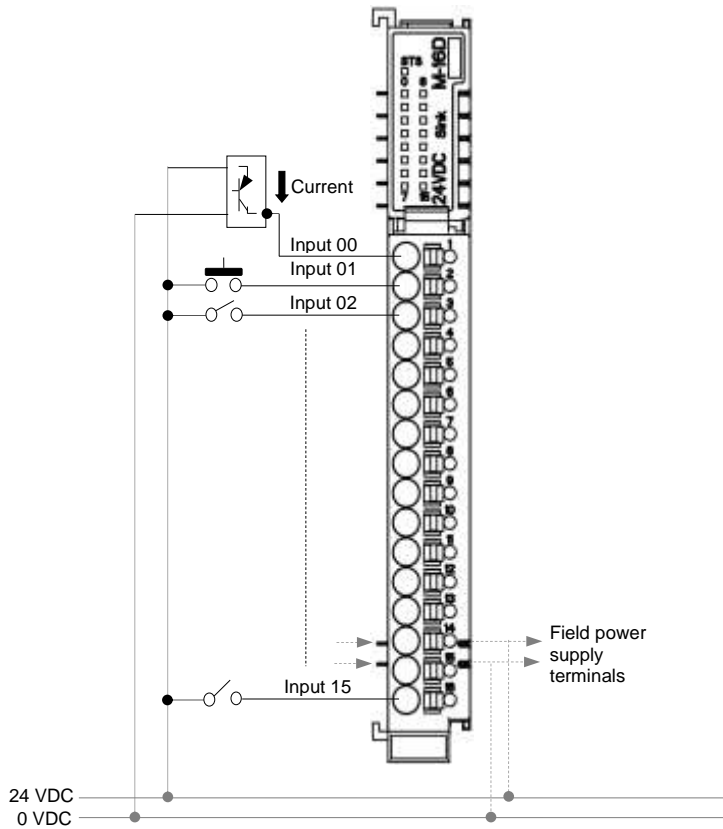

M-16D: Wiring description

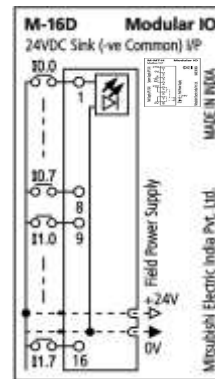

NOTE

24 VDC supply shown here and Field power supply connected to Header module (terminal numbers 5, 6 and 7, 8) should be same. Alternately, ensure that grounds (0V) are common if supply sources are different,

Some of the input devices like proximity switches may malfunction due to inherent off state leakage current. Ensure that proper bleeder resistor is connected as a load considering maximum specified OFF state current of input module.

Parameters

IO module can be configured in modular IO station using Modular IO Configurator. For addition and removal of IO module, refer section [Modular IO Configurator](#).

User can set the following module parameters.

Parameter Name	Project Value	Comment
Share diagnostics	Enable	Enables diagnostic data (SB) sharing with header.
	Disable [Default]	
Input Filter Time (ms)	10 (Default)	Defines input filter time in ms (Supported range : 3 to 70 msec).

Module diagnostic data is available in Status Byte (SB) memory, if module parameter “Share diagnostics” is set to Enable.

IO Data

The table below provides description of Digital input.

Channel	Data Type	Local Address*
Digital Input		
Digital Input 00-07	BYTE	IX n
DI 00	BOOL	IX n.0
⋮	⋮	⋮
DI 07	BOOL	IX n.7
Digital Input 10-17	BYTE	IX n+1
DI 10	BOOL	IX n+1.0
⋮	⋮	⋮
DI 17	BOOL	IX n+1.7

*Local address n changes as per the slot position of IO module and configuration of modular IO station.

User can monitor the following module diagnostics.

Module Diagnostics	Data Type	Local Address*	Bit Status	Description
No field power Supply	BOOL	SB n.0	TRUE	24VDC field power supply is not available
			FALSE	24VDC field power supply is available
Reserved	BOOL	SB n.1 to SB n.7	Reserved	Reserved

Module diagnostic data is available in Status Byte (SB) memory, if module parameter “Share diagnostics” is set to Enable.

Refer section [Troubleshooting](#) for station error code list and error messages.

6.4 M-4DE

[4 Point 24 VDC Digital Input Source Type
(Positive Common) Module]

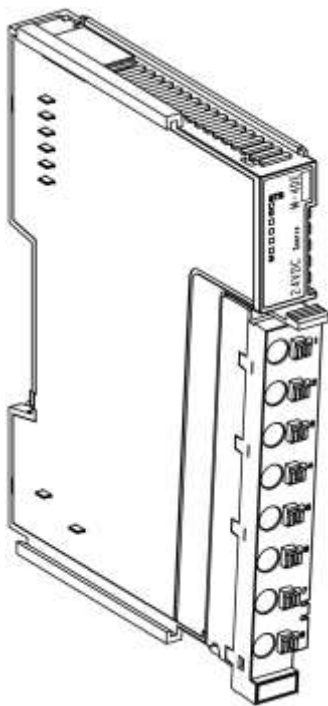

[Module Overview](#)

[Part Names](#)

[Specifications](#)

[LED Indications](#)

[Connection Diagram](#)

[Parameters](#)

[IO Data](#)

Module Overview

M-4DE is 4 point 24 VDC digital input module. It allows source type (positive common) of connections for all the inputs. The module can be fixed in any IO slot of modular IO station.

Part Names

The figure below describes part names of the module.

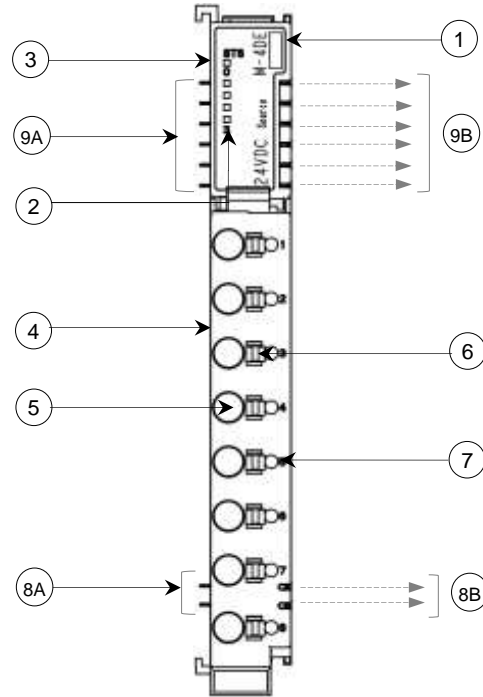

No.	Name	Description
1	M-4DE	Module ordering code
2	IO LED Indications	0 to 3: 4 Green colour LEDs for individual input status
3	Module LED Indication	STS: 1 Bi-colour LED for module status
4	Terminal Block	8-point removable push type
5	IO Point	Wire insertion point for IO terminal
6	Push Button	Press to release wire
7	Test Point	To measure signal voltage
8A	Field Power Supply Interface	2 Incoming pins for field power supply interface
8B		2 Outgoing pins for field power supply interface
9A	System Power Supply Interface	6 Incoming pins for system power supply interface
9B		6 Outgoing pins for system power supply interface

Specifications

The table below provides technical specifications of **M-4DE**.

Specification		Description
Ordering Code		M-4DE
Number of Inputs		4
Input Type		Source type (Positive common)
Voltage Rating		24 VDC (18 to 30 VDC including ripple)
Input Current		6 mA typical at 24 VDC
ON Voltage / ON Current		18 VDC or higher / 4.0 mA or higher
OFF Voltage / OFF Current		8 VDC or lower / 1.8 mA or lower
Transition Delay		3 ms to 70 ms [10 ms, Default]
Input Impedance		5.2 K Ω
Isolation		Between input and internal circuit Optical 1.5 KV
		Between inputs No isolation
IO Memory Consumption	Input Bits (IX)	4 points (1 byte)
	Diagnostics (SB) [User configurable]	1 byte
System Power Supply Consumption		40 mA
Field Power Supply Consumption		Number of inputs simultaneously ON X 6 mA
Terminal Block (Removable push type)		8 point
Recommended Wire Size*		0.5 sq. mm to 2.0 sq. mm (AWG 20 to 14), Solid wire or Stranded (flexible) wire with lugs
Module Dimensions (H x W x D) in mm		105 x 13.2 x 83

*Refer section [Wiring](#) for more details.

LED Indications

This section provides meaning of LED indications available on module.

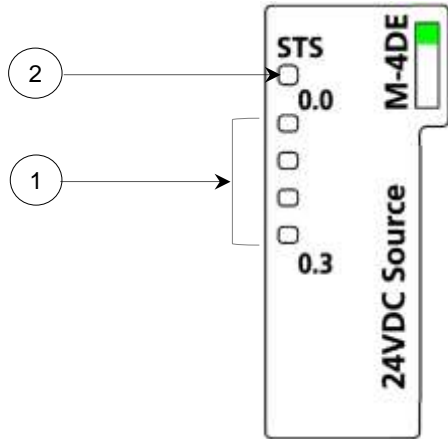

No.	*LED	Colour	Status	Description	
1	0.0 to 0.3	Green	ON	Input is ON	
			OFF	Input is OFF	
2	STS	Bi-colour LED	None	Module is powered OFF.	
			Blue Green	ON	Module is powered ON and communicating with Header module
				Single flash	Communication with Header is not established due to, <ul style="list-style-type: none"> - Module is powered ON and waiting for communication from Header. - Module mismatch
			Red	ON	Hardware failure is detected on module.
				Single flash	One of the following condition occurred. <ul style="list-style-type: none"> - No communication from Header - Backplane bus fault detected.
			Yellow	ON	24 VDC field power supply is not available

*For more details of LED indication states and flashing rates, refer section [Troubleshooting >> LED indications: States and flashing rates](#) in this manual.

Connection Diagram

The figure shows module front with 8-point terminal block, alongwith interface of field input devices like push buttons, limit switches and proximity switches for source operation i.e. with positive common.

Wiring description is provided on right side wall of the module.

For common wiring recommendations, refer section [Wiring](#).

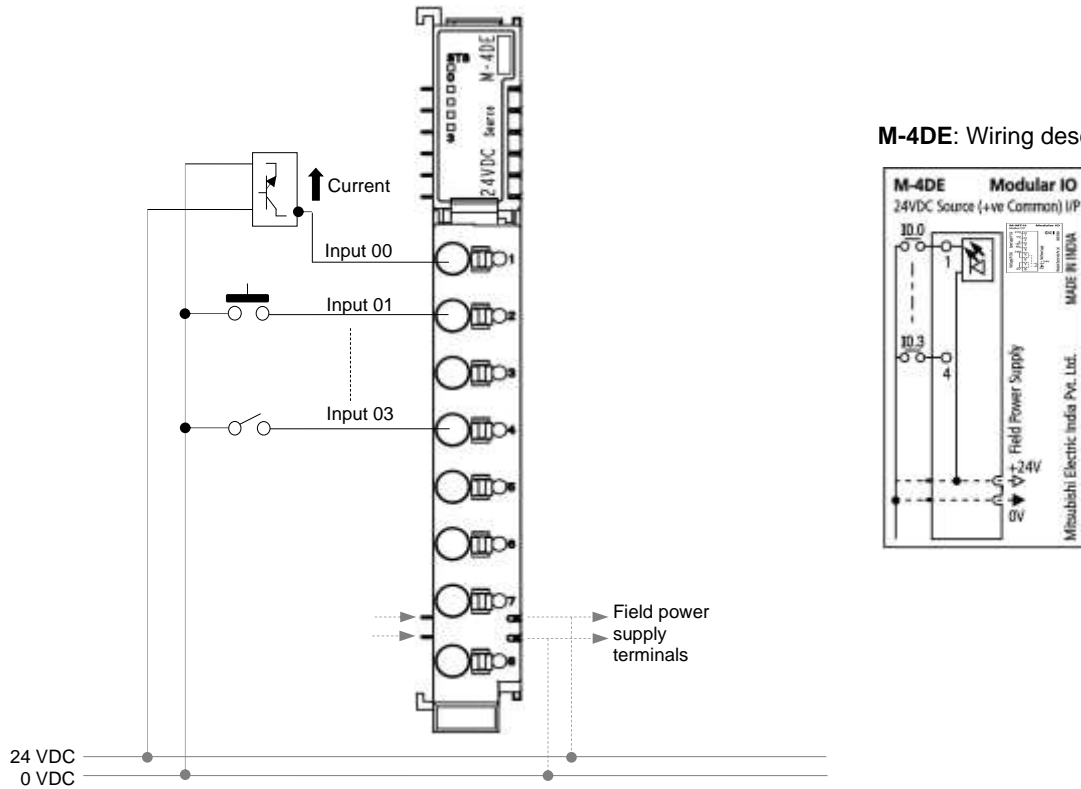

NOTE

24 VDC supply shown here and Field power supply connected to Header module (terminal numbers 5, 6 and 7, 8) should be same. Alternately, ensure that grounds (0V) are common if supply sources are different,

Some of the input devices like proximity switches may malfunction due to inherent off state leakage current. Ensure that proper bleeder resistor is connected as a load considering maximum specified OFF state current of input module.

Parameters

IO module can be configured in modular IO station using Modular IO Configurator. For addition and removal of IO module, refer section [Modular IO Configurator](#).

User can set the following module parameter.

Parameter Name	Project Value	Comment
Share diagnostics	Enable	Enables diagnostic data (SB) sharing with header
	Disable [Default]	
Input Filter Time (ms)	10 (Default)	Defines input filter time in ms (Supported range : 3 to 70 msec).

Module diagnostic data is available in Status Byte (SB) memory, if module parameter “Share diagnostics” is set to Enable.

IO Data

The table below provides description of Digital input.

Channel	Data Type	Local Address*
Digital Input		
Digital Input 00-03	BYTE	IX n
DI 00	BOOL	IX n.0
⋮	⋮	⋮
DI 03	BOOL	IX n.3

*Local address n changes as per the slot position of IO module and configuration of modular IO station.

User can monitor the following diagnostics.

Module Diagnostics	Data Type	Local Address*	Bit Status	Description
No field power Supply	BOOL	SB n.0	TRUE	24 VDC field power supply is not available
			FALSE	24 VDC field power supply is available
Reserved	BOOL	SB n.1 to SB n.7	Reserved	Reserved

Module diagnostic data is available in Status Byte (SB) memory, if module parameter “Share diagnostics” is set to Enable.

Refer section [Troubleshooting](#) for station error code list and error messages.

6.5 M-8DE

[8 Point 24 VDC Digital Input Source Type
(Positive Common) Module]

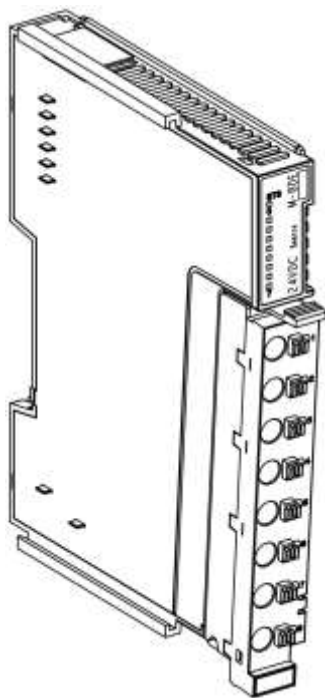

[Module Overview](#)

[Part Names](#)

[Specifications](#)

[LED Indications](#)

[Connection Diagram](#)

[Parameters](#)

[IO Data](#)

Module Overview

M-8DE is 8 point 24 VDC digital input module. It allows source type (positive common) of connections for all the inputs. The module can be fixed in any IO slot of modular IO station.

Part Names

The figure below describes part names of the module.

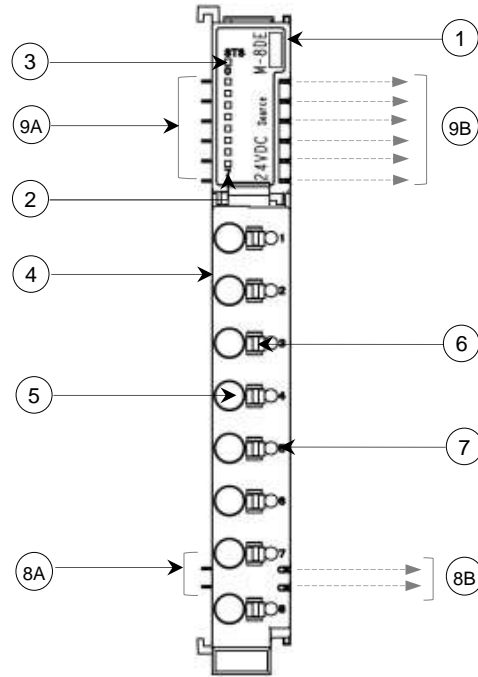

No.	Name	Description
1	M-8DE	Module ordering code
2	IO LED Indications	0 to 7: 8 Green colour LEDs for individual input status
3	Module LED Indication	STS: 1 Bi-colour LED for module status
4	Terminal Block	8-point removable push type
5	IO Point	Wire insertion point for IO terminal
6	Push Button	Press to release wire
7	Test Point	To measure signal voltage
8A	Field Power Supply Interface	2 Incoming pins for field power supply interface
8B		2 Outgoing pins for field power supply interface
9A	System Power Supply Interface	6 Incoming pins for system power supply interface
9B		6 Outgoing pins for system power supply interface

Specifications

The table below provides technical specifications of **M-8DE**.

Specification		Description
Ordering Code		M-8DE
Number of Inputs		8
Input Type		Source type (Positive common)
Voltage Rating		24 VDC (18 to 30 VDC including ripple)
Input Current		6 mA typical at 24 VDC
ON Voltage / ON Current		18 VDC or higher / 4.0 mA or higher
OFF Voltage / OFF Current		8 VDC or lower / 1.8 mA or lower
Transition Delay		3 ms to 70 ms [10 ms, Default]
Input Impedance		5.2 K Ω
Isolation		Between input and internal circuit
		Optical 1.5 KV
IO Memory Consumption		Between inputs
		No isolation
Input Bits (IX)	8 points (1 byte)	
Diagnostics (SB) [User configurable]	1 byte	
System Power Supply Consumption		45 mA
Field Power Supply Consumption		Number of inputs simultaneously ON X 6 mA
Terminal Block (Removable push type)		8 point
Recommended Wire Size*		0.5 sq. mm to 2.0 sq. mm (AWG 20 to 14), Solid wire or Stranded (flexible) wire with lugs
Module Dimensions (H x W x D) in mm		105 x 13.2 x 83

*Refer section [Wiring](#) for more details.

LED Indications

This section provides meaning of LED indications available on module.

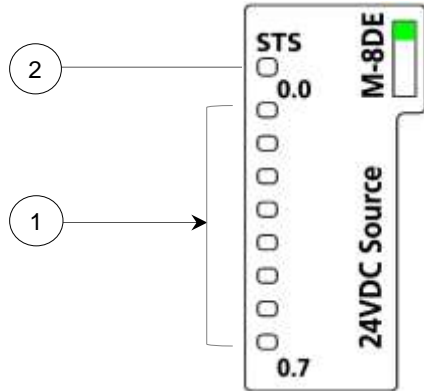

No.	*LED	Colour	Status	Description	
1	0.0 to 0.7	Green	ON	Input is ON	
			OFF	Input is OFF	
2	STS	Bi-colour LED	None	Module is powered OFF.	
			Blue Green	ON	Module is powered ON and communicating with Header module
				Single flash	Communication with Header is not established due to, <ul style="list-style-type: none"> - Module is powered ON and waiting for communication from Header. - Module mismatch
			Red	ON	Hardware failure is detected on module.
				Single flash	One of the following condition occurred. <ul style="list-style-type: none"> - No communication from Header - Backplane bus fault detected.
Yellow	ON	24VDC field power supply is not available			

*For more details of LED indication states and flashing rates, refer section [Troubleshooting >> LED indications: States and flashing rates](#) in this manual.

Connection Diagram

The figure shows module front with 8-point terminal block, alongwith interface of field input devices like push buttons, limit switches and proximity switches for source operation i.e. with positive common.

Wiring description is provided on right side wall of the module.

For common wiring recommendations, refer section [Wiring](#).

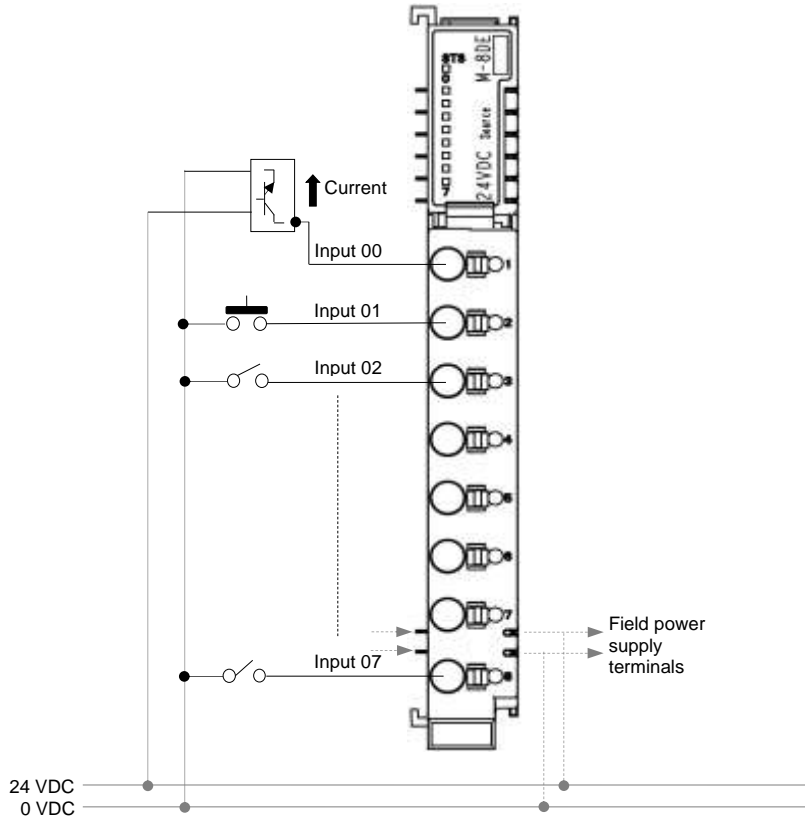

M-8DE: Wiring description

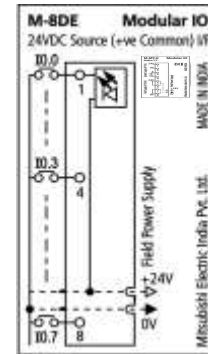

NOTE

24 VDC supply shown here and Field power supply connected to Header module (terminal numbers 5, 6 and 7, 8) should be same. Alternately, ensure that grounds (0V) are common if supply sources are different,

Some of the input devices like proximity switches may malfunction due to inherent off state leakage current. Ensure that proper bleeder resistor is connected as a load considering maximum specified OFF state current of input module.

Parameters

IO module can be configured in modular IO station using Modular IO Configurator. For addition and removal of IO module, refer section [Modular IO Configurator](#).

User can set the following module parameters

Parameter Name	Project Value	Comment
Share diagnostics	Enable	Enables diagnostic data (SB) sharing with header
	Disable [Default]	
Input Filter Time (ms)	10 (Default)	Defines input filter time in ms (Supported range : 3 to 70 msec).

Module diagnostic data is available in Status Byte (SB) memory, if module parameter "Share diagnostics" is set to Enable.

IO Data

The table below provides description of Digital input.

Channel	Data Type	Local Address*
Digital Input		
Digital Input 00-07	BYTE	IX n
DI 00	BOOL	IX n.0
⋮	⋮	⋮
DI 07	BOOL	IX n.7

*Local address n changes as per the slot position of IO module and configuration of modular IO station.

User can monitor the following diagnostics.

Module Diagnostics	Data Type	Local Address*	Bit Status	Description
No field power Supply	BOOL	SB n.0	TRUE	24 VDC field power supply is not available
			FALSE	24 VDC field power supply is available
Reserved	BOOL	SB n.1 to SB n.7	Reserved	Reserved

Module diagnostic data is available in Status Byte (SB) memory, if module parameter "Share diagnostics" is set to Enable.

Refer section [Troubleshooting](#) for station error code list and error messages.

6.6 M-16DE

[16 Point 24 VDC Digital Input Source Type (Positive Common) Module]

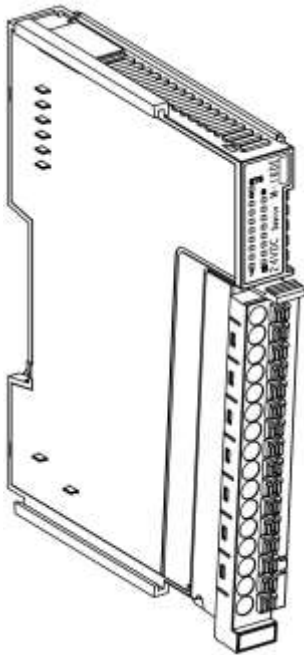

[Module Overview](#)

[Part Names](#)

[Specifications](#)

[LED Indications](#)

[Connection Diagram](#)

[Parameters](#)

[IO Data](#)

Module Overview

M-16DE is 16 point 24 VDC digital input module. It allows source type (positive common) of connections for all the inputs. The module can be fixed in any IO slot of modular IO station.

Part Names

The figure below describes part names of the module.

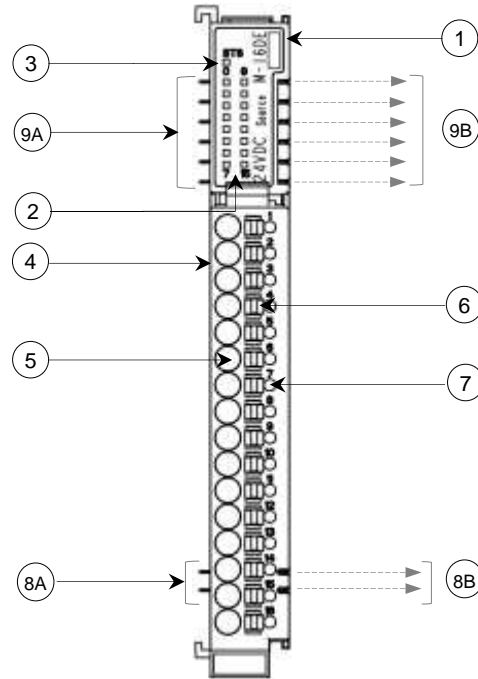

No.	Name	Description
1	M-16DE	Module ordering code
2	IO LED Indications	0 to 15: 16 Green colour LEDs for individual input status
3	Module LED Indication	STS: 1 Bi-colour LED for module status
4	Terminal Block	16-point removable push type
5	IO Point	Wire insertion point for IO terminal
6	Push Button	Press to release wire
7	Test Point	To measure signal voltage
8A	Field Power Supply Interface	2 Incoming pins for field power supply interface
8B		2 Outgoing pins for field power supply interface
9A	System Power Supply Interface	6 Incoming pins for system power supply interface
9B		6 Outgoing pins for system power supply interface

Specifications

The table below provides technical specifications of **M-16DE**.

Specification		Description	
Ordering Code		M-16DE	
Number of Inputs		16	
Input Type		Source type (Positive common)	
Voltage Rating		24 VDC (18 to 30 VDC including ripple)	
Input Current		6 mA typical at 24 VDC	
ON Voltage / ON Current		18 VDC or higher / 4.0 mA or higher	
OFF Voltage / OFF Current		8 VDC or lower / 1.8 mA or lower	
Transition Delay		3 ms to 70 ms [10 ms, Default]	
Input Impedance		5.2 K Ω	
Isolation		Between input and internal circuit	Optical 1.5 KV
		Between inputs	No isolation
IO Memory Consumption	Input Bits (IX)	16 points (2 bytes)	
	Diagnostics (SB) [User configurable]	1 byte	
System Power Supply Consumption		65 mA	
Field Power Supply Consumption		Number of inputs simultaneously ON X 6 mA	
Terminal Block (Removable push type)		16 point	
Recommended Wire Size*		0.5 to 1.0 sq. mm (AWG 20 to 16) Solid wire or Stranded (flexible) wire with lugs	
Module Dimensions (H x W x D) in mm		105 x 13.2 x 83	

*Refer section [Wiring](#) for more details.

LED Indications

This section provides meaning of LED indications available on module.

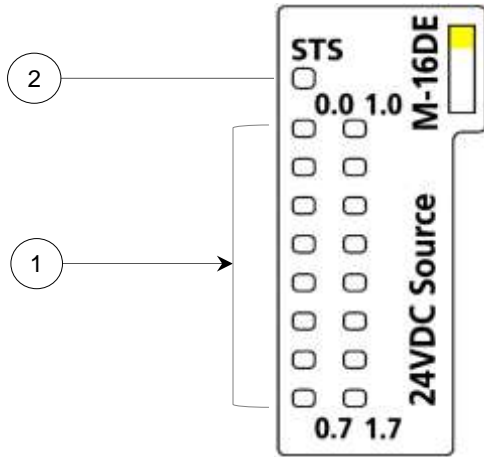

No.	*LED	Colour	Status	Description	
1	0.0 to 0.7, 1.0 to 1.7	Green	ON	Input is ON	
			OFF	Input is OFF	
2	STS	Bi-colour LED	None	Module is powered OFF.	
			Blue Green	ON	Module is powered ON and communicating with Header module
				Single flash	Communication with Header is not established due to, <ul style="list-style-type: none"> - Module is powered ON and waiting for communication from Header. - Module mismatch
			Red	ON	Hardware failure is detected on module.
				Single flash	One of the following conditions occurred. <ul style="list-style-type: none"> - No communication from Header - Backplane bus fault detected.
Yellow	ON	24VDC field power supply is not available			

*For more details of LED indication states and flashing rates, refer section [Troubleshooting >> LED indications: States and flashing rates](#) in this manual.

Connection Diagram

The figure shows module front with 16-point terminal block, alongwith interface of field input devices like push buttons, limit switches and proximity switches for source operation i.e. with positive common.

Wiring description is provided on right side wall of the module.

For common wiring recommendations, refer section [Wiring](#).

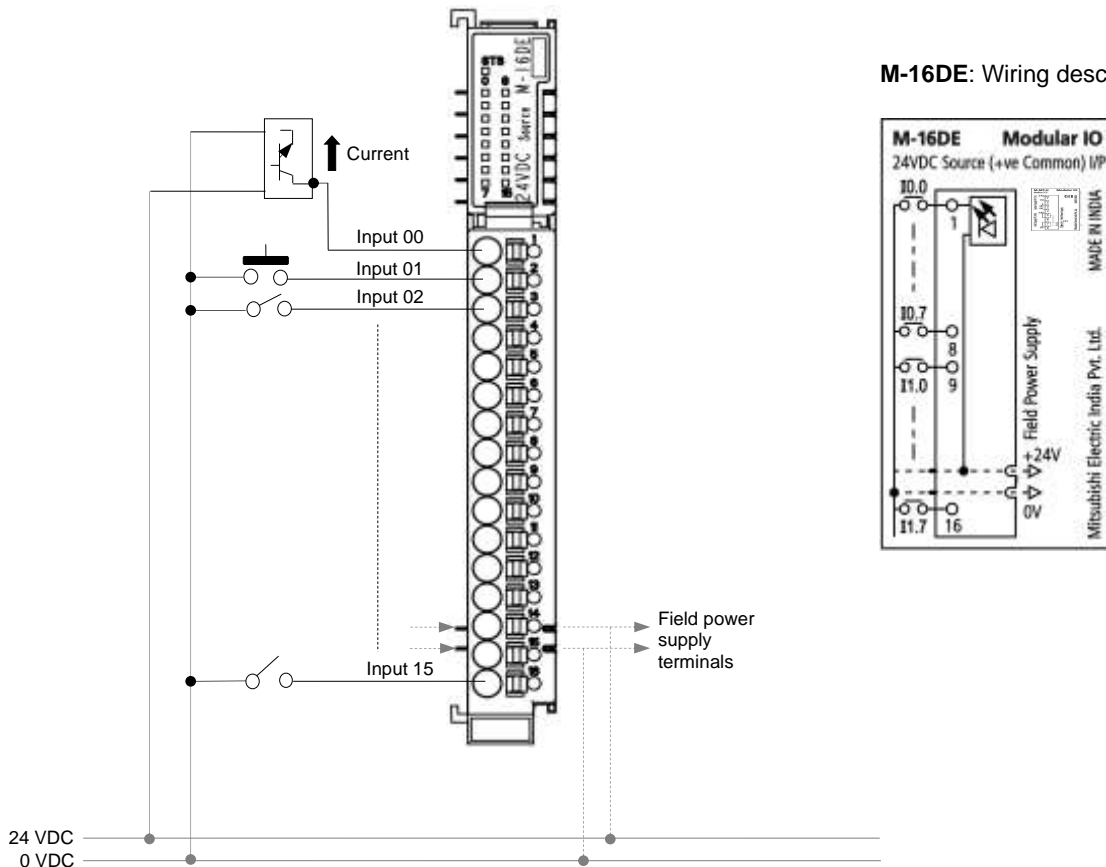

NOTE

24 VDC supply shown here, and Field power supply connected to Header module (terminal numbers 5,6 and 7,8) should be same. Alternately, ensure that grounds (0V) are common if supply sources are different,

Some of the input devices like proximity switches may malfunction due to inherent off state leakage current. Ensure that proper bleeder resistor is connected as a load considering maximum specified OFF state current of input module.

Parameters

IO module can be configured in modular IO station using Modular IO Configurator. For addition and removal of IO module, refer section [Modular IO Configurator](#).

User can set the following module parameters

Parameter Name	Project Value	Comment
Share diagnostics	Enable	Enables diagnostic data (SB) sharing with header
	Disable [Default]	
Input Filter Time (ms)	10 (Default)	Defines input filter time in ms (Supported range : 3 to 70 msec).

Module diagnostic data is available in Status Byte (SB) memory, if module parameter "Share diagnostics" is set to Enable.

IO Data

The table below provides description of Digital input.

Channel	Data Type	Local Address*
Digital Input		
Digital Input 00-07	BYTE	IX n
DI 00	BOOL	IX n.0
⋮	⋮	⋮
DI 07	BOOL	IX n.7
Digital Input 10-17	BYTE	IX n+1
DI 10	BOOL	IX n+1.0
⋮	⋮	⋮
DI 17	BOOL	IX n+1.7

*Local address n changes as per the slot position of IO module and configuration of modular IO station.

User can monitor the following module diagnostics.

Module Diagnostics	Data Type	Local Address*	Bit Status	Description
No field power Supply	BOOL	SB n.0	TRUE	24VDC field power supply is not available
			FALSE	24VDC field power supply is available
Reserved	BOOL	SB n.1 to SB n.7	Reserved	Reserved

Module diagnostic data is available in Status Byte (SB) memory, if module parameter "Share diagnostics" is set to Enable.

Refer section [Troubleshooting](#) for station error code list and error messages.

6.7 M-4TE

[4 Point 24 VDC Transistor Output (Source) Module]

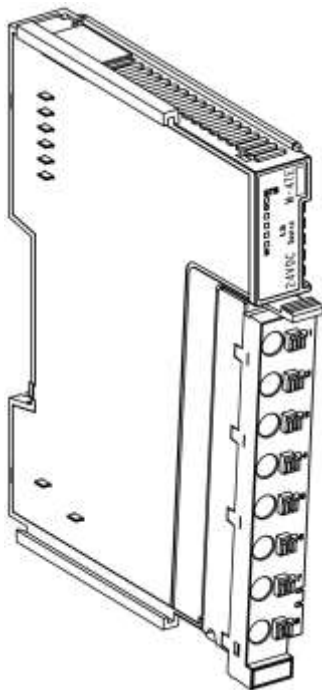

[Module Overview](#)

[Part Names](#)

[Specifications](#)

[LED Indications](#)

[Connection Diagram](#)

[Parameters](#)

[IO Data](#)

Module Overview

M-4TE is 4-point transistor output (source) module. It allows source type of connections with field output devices. The module can be fixed in any IO slot of modular IO station.

Part Names

The figure below describes part names of the module.

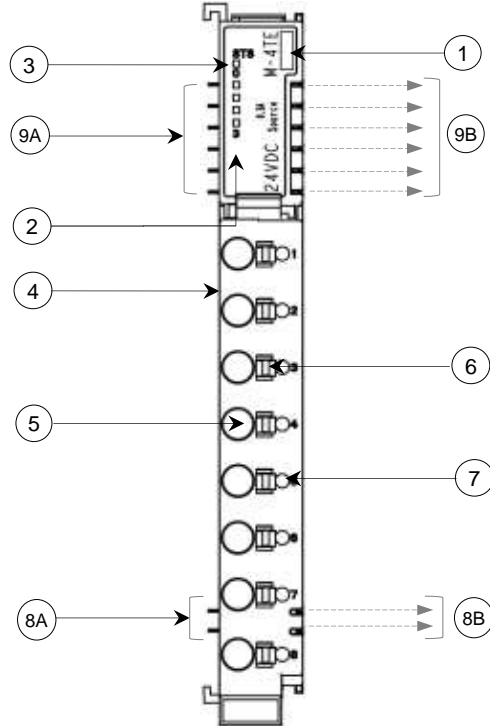

No.	Name	Description
1	M-4TE	Module ordering code
2	IO LED Indication	0 to 3: 4, Red colour LEDs for individual output status
3	Module LED Indication	STS: 1, Bi-colour LED for module status
4	Terminal Block	16-point removable push type
5	IO Point	Wire insertion point for IO terminal
6	Push Button	Press to release wire
7	Test Point	To measure signal voltage
8A	Field power supply Interface	2 Incoming pins for field power supply interface
8B		2 Outgoing pins for field power supply interface
9A	System power supply Interface	6 Incoming pins for system power supply interface
9B		6 Outgoing pins for system power supply interface

Specifications

The table below provides technical specifications of **M-4TE**.

Specification		Description	
Ordering Code		M-4TE	
Number of Outputs		4	
Output Type		Source type	
Output Device		Transistor	
Voltage Rating		24 VDC (18 to 30 V including ripple)	
Current Rating		0.5 A per output	
ON Voltage Drop		0.6 VDC maximum	
ON State Resistance		200 mΩ	
OFF State Leakage Current		10 μA maximum	
Response Time		OFF to ON	250 μsecs
		ON to OFF	300 μsecs
Isolation		Between output and internal circuit	Optical 1.5 KV
Protection		<ul style="list-style-type: none"> - Output short circuit protection: Protection is not designed for continuous repetitive operations. - Fast demagnetization for inductive loads 	
IO Memory Consumption	Output Bits (QX)	4 points (1 byte)	
	Diagnostics (SB) [User configurable]	1 byte	
System Power Supply Consumption		90 mA	
Field Power Supply Consumption		Sum of output loads simultaneously ON.	
Terminal Block (Removable push type)		8 point	
Recommended Wire Size*		0.5 sq. mm to 2.0 sq. mm (AWG 20 to 14), Solid wire or Stranded (flexible) wire with lugs	
Module Dimensions (H x W x D) in mm		105 x 13.2 x 83	

*Refer section [Wiring](#) for more details.

LED Indications

This section provides meaning of LED indications available on module.

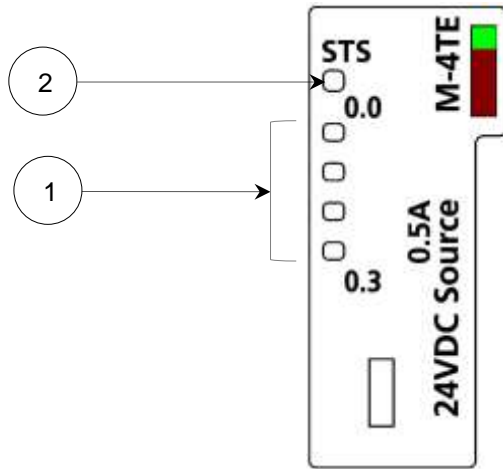

No.	*LED	Colour	Status	Description	
1	0.0 to 0.3	Red	ON	Output is ON	
			OFF	Output is OFF	
2	STS	Bi-colour LED	None	Module is powered OFF.	
			Blue Green	ON	Module is powered ON and communicating with Header module
				Single flash	Communication with Header is not established due to, <ul style="list-style-type: none"> - Module is powered ON and waiting for communication from Header. - Module mismatch
			Red	ON	Hardware failure is detected on module.
				Single flash	One of the following condition occurred. <ul style="list-style-type: none"> - No communication from Header - Backplane bus fault detected.
Yellow	ON	24 VDC field power supply is not available			

*For more details of LED indication states and flashing rates, refer section [Troubleshooting >> LED indications: States and flashing rates](#) in this manual.

Connection Diagram

The figure shows module front with 8-point terminal block, along with interface to field output devices like solenoid valves, for source operation.

Wiring description is provided on right side wall of the module.

For common wiring recommendations, refer section [Wiring](#).

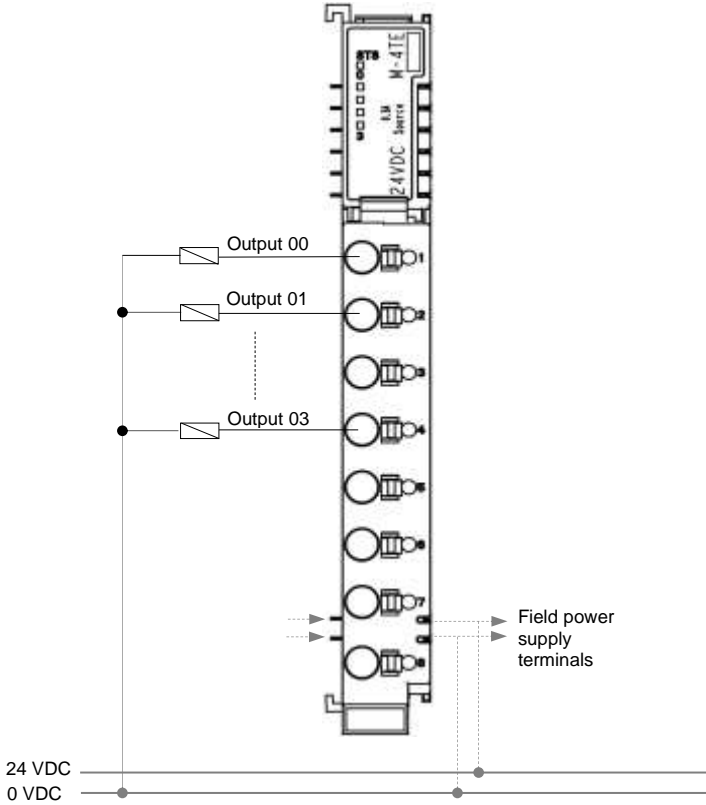

M-4TE: Wiring description

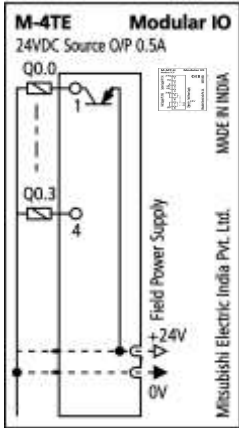

NOTE

24 VDC supply shown here and Field power supply connected to Header module (terminal numbers 5, 6 and 7, 8) should be same. Alternately, ensure that grounds (0V) are common if supply sources are different,

Parameters

IO module can be configured in modular IO station using Modular IO Configurator. For addition and removal of IO module, refer section [Modular IO Configurator](#).

User can set module parameters.

Parameter Name	Project Value	Comment
Share diagnostics	Enable	Enables diagnostic data (SB) sharing with header
	Disable [Default]	

Module diagnostic data is available in Status Byte (SB) memory, if module parameter “Share diagnostics” is set to Enable.

IO Data

The table below provides description of Digital output.

Channel	Data Type	Local Address*
Digital output		
Digital Output 00-03	BYTE	QX n
DO 00	BOOL	QX n.0
⋮	⋮	⋮
DO 03	BOOL	QX n.3

*Local address (n) value changes as per the slot position of IO module and configuration of modular IO station.

User can monitor the following diagnostics.

Module Diagnostics	Data Type	Local Address*	Bit Status	Description
No field power Supply	BOOL	SB n.0	TRUE	24 VDC field power supply is not available
			FALSE	24 VDC field power supply is available
Reserved	BOOL	SB n.1 to SB n.7	Reserved	Reserved

Module diagnostic data is available in Status Byte (SB) memory, if module parameter “Share diagnostics” is set to Enable.

Refer section [Troubleshooting](#) for station error code list and error messages.

6.8 M-8TE

[8 Point 24 VDC Transistor Output (Source) Module]

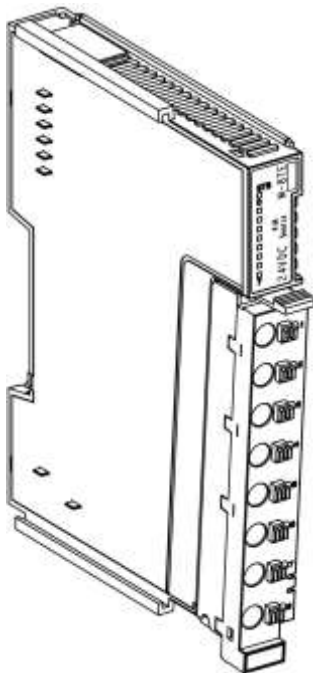

[Module Overview](#)

[Part Names](#)

[Specifications](#)

[LED Indications](#)

[Connection Diagram](#)

[Parameters](#)

[IO Data](#)

Module Overview

M-8TE is 8-point transistor output (source) module. It allows source type of connections with field output devices. The module can be fixed in any IO slot of modular IO station.

Part Names

The figure below describes part names of the module.

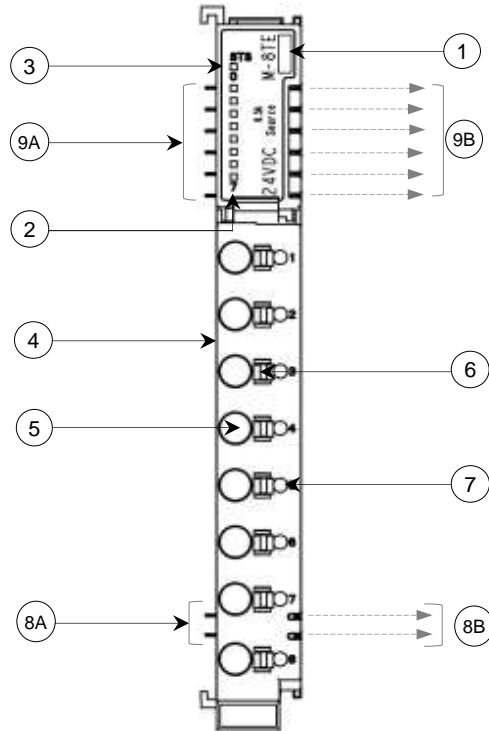

No.	Name	Description
1	M-8TE	Module ordering code
2	IO LED Indication	0 to 7: 8, Red colour LEDs for individual output status
3	Module LED Indication	STS: 1, Bi-colour LED for module status
4	Terminal Block	8-point removable push type
5	IO Point	Wire insertion point for IO terminal
6	Push Button	Press to release wire
7	Test Point	To measure signal voltage
8A	Field power supply Interface	2 Incoming pins for field power supply interface
8B		2 Outgoing pins for field power supply interface
9A	System power supply Interface	6 Incoming pins for system power supply interface
9B		6 Outgoing pins for system power supply interface

Specifications

The table below provides technical specifications of **M-8TE**

Specification		Description
Ordering Code		M-8TE
Number of Outputs		8
Output Type		Source type
Output Device		Transistor
Voltage Rating		24 VDC (18 to 30 V including ripple)
Current Rating		0.5 A per output
ON Voltage Drop		0.6 VDC maximum
ON State Resistance		200 mΩ
OFF State Leakage Current		10 μA maximum
Response Time		OFF to ON 250 μsecs
		ON to OFF 300 μsecs
Isolation		Between output and internal circuit Optical 1.5 KV
Protection		<ul style="list-style-type: none"> - Output short circuit protection: Protection is not designed for continuous repetitive operations. - Fast demagnetization for inductive loads
IO Memory Consumption	Output Bits (QX)	8 points (1 byte)
	Diagnostics (SB) [User configurable]	1 byte
System Power Supply Consumption		105 mA
Field Power Supply Consumption		Sum of output loads simultaneously ON.
Terminal Block (Removable push type)		8 point
Recommended Wire Size*		0.5 sq. mm to 2.0 sq. mm (AWG 20 to 14), Solid wire or Stranded (flexible) wire with lugs
Module Dimensions (H x W x D) in mm		105 x 13.2 x 83

*Refer section [Wiring](#) for more details.

LED Indications

This section provides meaning of LED indications available on module.

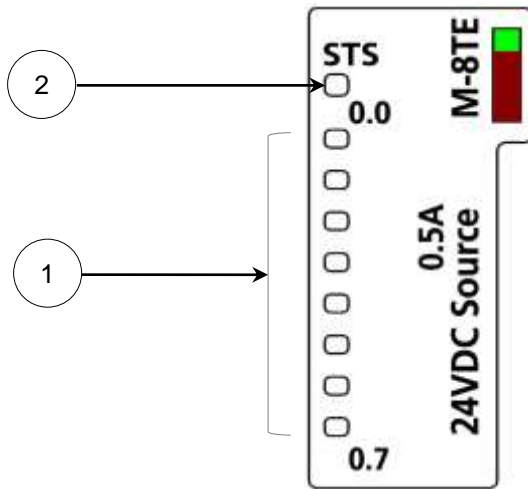

No.	*LED	Colour	Status	Description	
1	0.0 to 0.7	Red	ON	Output is ON	
			OFF	Output is OFF	
2	STS	Bi-colour LED	None	Module is powered OFF.	
			Blue Green	ON	Module is powered ON and communicating with Header module
				Single flash	Communication with Header is not established due to, <ul style="list-style-type: none"> - Module is powered ON and waiting for communication from Header. - Module mismatch
			Red	ON	Hardware failure is detected on module.
				Single flash	One of the following condition occurred. <ul style="list-style-type: none"> - No communication from Header - Backplane bus fault detected.
Yellow	ON	24 VDC field power supply is not available			

*For more details of LED indication states and flashing rates, refer section [Troubleshooting >> LED indications: States and flashing rates](#) in this manual.

Connection Diagram

The figure shows module front with 8-point terminal block, along with interface to field output devices like solenoid valves for source operation.

Wiring description is provided on right side wall of the module.

For common wiring recommendations, refer section [Wiring](#).

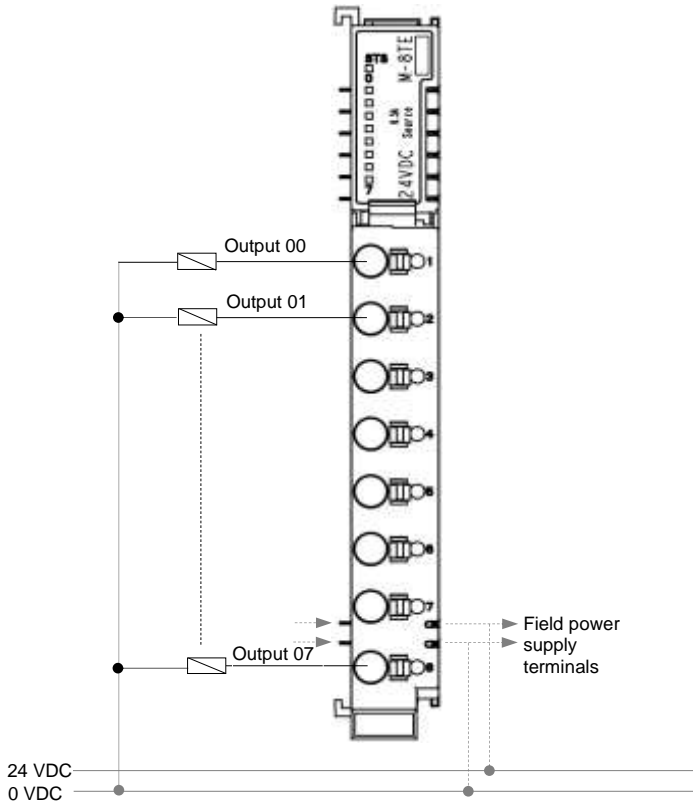

M-8TE: Wiring description

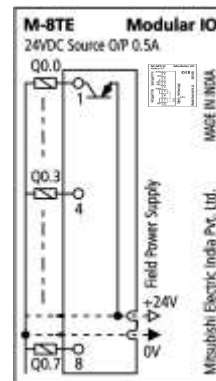

NOTE

24 VDC supply shown here and Field power supply connected to Header module (terminal numbers 5, 6 and 7, 8) should be same. Alternately, ensure that grounds (0V) are common if supply sources are different.

Parameters

IO module can be configured in modular IO station using Modular IO Configurator. For addition and removal of IO module, refer section [Modular IO Configurator](#).

User can set module parameters.

Parameter Name	Project Value	Comment
Share diagnostics	Enable	Enables diagnostic data (SB) sharing with header
	Disable [Default]	

Module diagnostic data is available in Status Byte (SB) memory, if module parameter "Share diagnostics" is set to Enable.

IO Data

The table below provides description of Digital output.

Channel	Data Type	Local Address*
Digital output		
Digital Output 00-07	BYTE	QX (n)
DO 00	BOOL	QX (n).0
⋮	⋮	⋮
DO 07	BOOL	QX (n).7

*Local address (n) value changes as per the slot position of IO module and configuration of modular IO station.

User can monitor the following diagnostics.

Module Diagnostics	Data Type	Local Address*	Bit Status	Description
No field power Supply	BOOL	SB n.0	TRUE	24 VDC field power supply is not available
			FALSE	24 VDC field power supply is available
Reserved	BOOL	SB n.1 to SB n.7	Reserved	Reserved

Module diagnostic data is available in Status Byte (SB) memory, if module parameter "Share diagnostics" is set to Enable.

Refer section [Troubleshooting](#) for station error code list and error messages.

6.9 M-16TE

[16 Point 24 VDC Transistor Output (Source) Module]

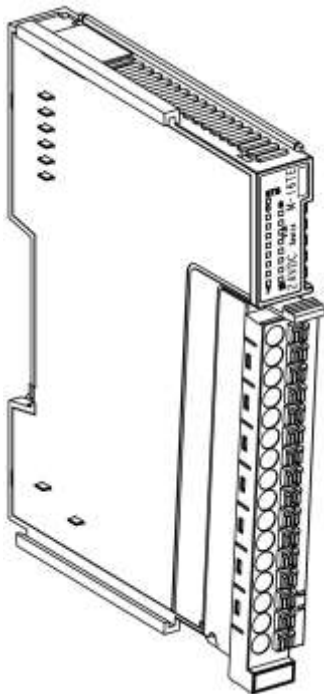

[Module Overview](#)

[Part Names](#)

[Specifications](#)

[LED Indications](#)

[Connection Diagram](#)

[Parameters](#)

[IO Data](#)

Module Overview

M-16TE is 16-point transistor output (source) module. It allows source type of connections with field output devices. The module can be fixed in any IO slot of modular IO station.

Part Names

The figure below describes part names of the module.

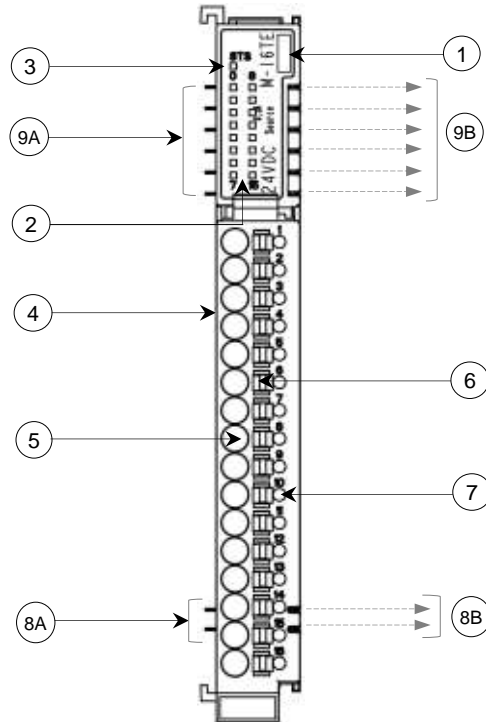

No.	Name	Description
1	M-16TE	Module ordering code
2	IO LED Indication	0 to 15: 16, Red colour LEDs for individual output status
3	Module LED Indication	STS: 1, Bi-colour LED for module status
4	Terminal Block	16-point removable push type
5	IO Point	Wire insertion point for IO terminal
6	Push Button	Press to release wire
7	Test Point	To measure signal voltage
8A	Field Power Supply Interface	2 Incoming pins for field power supply interface
8B		2 Outgoing pins for field power supply interface
9A	System Power Supply Interface	6 Incoming pins for system power supply interface
9B		6 Outgoing pins for system power supply interface

Specifications

The table below provides technical specifications of **M-16TE**.

Specification		Description
Ordering Code		M-16TE
Number of Outputs		16
Output Type		Source type
Output Device		Transistor
Voltage Rating		24 VDC (18 to 30 V including ripple)
Current Rating		0.5 A per output, 6 A maximum per module
ON Voltage Drop		0.6 VDC maximum
ON State Resistance		200 mΩ
OFF State Leakage Current		10 μA maximum
Response Time		OFF to ON 250 μsecs
		ON to OFF 300 μsecs
Isolation		Between output and internal circuit Optical 1.5 KV
Protection		<ul style="list-style-type: none"> - Output short circuit protection: Protection is not designed for continuous repetitive operations. - Fast demagnetization for inductive loads
IO Memory Consumption	Output Bits (QX)	16 points (2 bytes)
	Diagnostics (SB) [User configurable]	1 byte
System Power Supply Consumption		130 mA
Field Power Supply Consumption		Sum of output loads simultaneously ON.
Terminal Block (Removable push type)		16 point
Recommended Wire Size*		0.5 to 1.0 sq. mm (AWG 20 to 16) Solid wire or Stranded (flexible) wire with lugs
Module Dimensions (H x W x D) in mm		105 x 13.2 x 83

*Refer section [Wiring](#) for more details.

LED Indications

This section provides meaning of LED indications available on module.

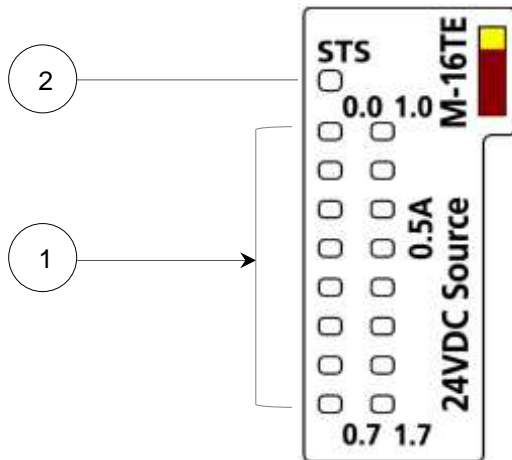

No.	*LED	Colour	Status	Description	
1	0.0 to 0.7 1.0 to 1.7	Red	ON	Output is ON	
			OFF	Output is OFF	
2	STS	Bi-colour LED	None	Module is powered OFF.	
			Blue Green	ON	Module is powered ON and communicating with Header module
				Single flash	Communication with Header is not established due to, <ul style="list-style-type: none"> - Module is powered ON and waiting for communication from Header. - Module mismatch
			Red	ON	Hardware failure is detected on module.
				Single flash	One of the following condition occurred. <ul style="list-style-type: none"> - No communication from Header - Backplane bus fault detected.
Yellow	ON	24 VDC field power supply is not available			

*For more details of LED indication states and flashing rates, refer section [Troubleshooting >> LED indications: States and flashing rates](#) in this manual.

Connection Diagram

The figure shows module front with 16-point terminal block, along with interface to field output devices like solenoid valves for source operation.

Wiring description is provided on right side wall of the module.

For common wiring recommendations, refer section [.Wiring.](#)

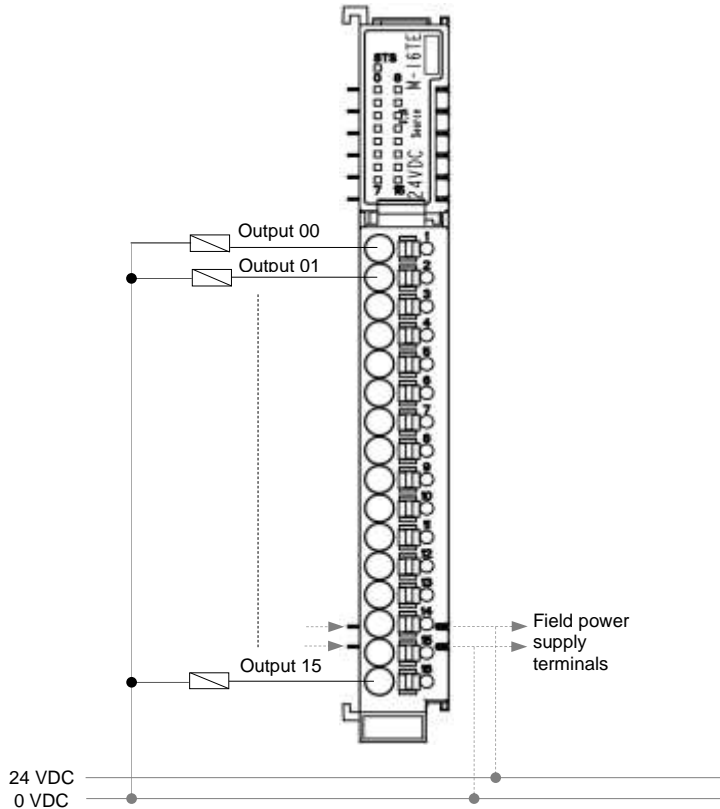

M-16TE: Wiring description

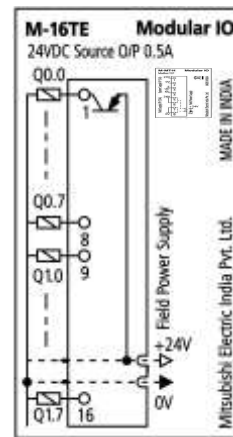

NOTE

24 VDC supply shown here and Field power supply connected to Header module (terminal numbers 5, 6 and 7, 8) should be same. Alternately, ensure that grounds (0V) are common if supply sources are different.

Parameters

IO module can be configured in modular IO station using Modular IO Configurator. For addition and removal of IO module, refer section [Modular IO Configurator](#).

User can set module parameters.

Parameter Name	Project Value	Comment
Share diagnostics	Enable	Enables diagnostic data (SB) sharing with header
	Disable [Default]	

Module diagnostic data is available in Status Byte (SB) memory, if module parameter “Share diagnostics” is set to Enable.

IO Data

The table below provides description of Digital output.

Channel	Data Type	Local Address*
Digital output		
Digital Output 00-07	BYTE	QX (n)
DO 00	BOOL	QX (n).0
⋮	⋮	⋮
DO 07	BOOL	QX (n).7
Digital Output 10-17		
DO 10	BOOL	QX (n+1).0
⋮	⋮	⋮
DO 17	BOOL	QX (n+1).7

*Local address (n) value changes as per the slot position of IO module and configuration of modular IO station.

User can monitor the following diagnostics.

Module Diagnostics	Data Type	Local Address*	Bit Status	Description
No field power Supply	BOOL	SB n.0	TRUE	24 VDC field power supply is not available
			FALSE	24 VDC field power supply is available
Reserved	BOOL	SB n.1 to SB n.7	Reserved	Reserved

Module diagnostic data is available in Status Byte (SB) memory, if module parameter “Share diagnostics” is set to Enable.

Refer section [Troubleshooting](#) for station error code list and error messages

[Back To Index Page](#)

7 Analog IO Modules







Analog IO Modules: Overview	
2 Channel Universal Analog Input Module	M-UAD2
4 Channel Analog V/I Input Module	M-AD4
8 Channel Analog Voltage Input Module	M-ADV8
8 Channel Analog Current Input Module	M-ADI8
4 Channel Thermocouple/ RTD Input Module	M-TCRT4
2 Channel Analog Voltage/ Current Output Module	M-DA2
4 Channel Analog Voltage/ Current Output Module	M-DA4

Overview

Analog input module converts input voltage, current, RTD and thermocouple readings into equivalent binary values.

Analog output module takes digital value data from processor and generates equivalent analog output voltage or current as per channel configuration.

In modular IO station, different types of analog IO modules are available as below,

Ordering Information	Ordering Code	Colour Identification*
Analog Input		
2 Channel Universal Analog Input Module	M-UAD2	
4 Channel V/ I Analog Input Module	M-AD4	
8 Channel Analog Voltage Input Module	M-ADV8	
8 Channel Analog Current Input Module	M-ADI8	
4 Channel Thermocouple/ RTD Input Module	M-TCRT4	
Analog Output		
2 Channel V/ I Analog Output Module	M-DA2	
4 Channel V/ I Analog Output Module	M-DA4	

*Color code is provided on LED label and at bottom side of terminal block. User should always ensure that color code of LED label and terminal block is identical.

NOTE

For analog input and output modules, it is recommended to route IO cables carrying low level signals like analog signals, separately and away from cables carrying high voltage and high current.

7.1 M-UAD2

[2 CH. Universal Analog Input Module]

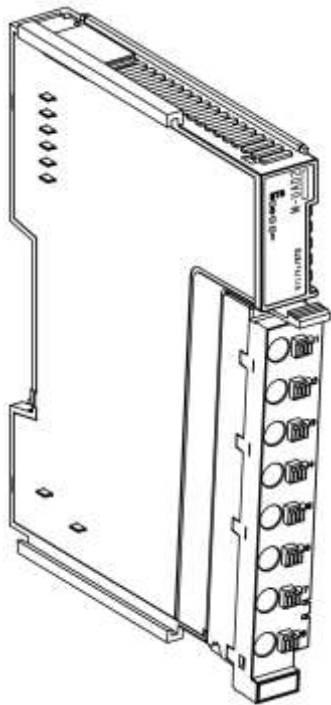

[Module Overview](#)

[Part Names](#)

[Specifications](#)

[LED Indications](#)

[Connection Diagram](#)

[User Configurable Features](#)

[Parameters](#)

[IO Data](#)

Module Overview

M-UAD2 is 2 channel universal analog input module. Highlighting features are as below

- Supports various types of inputs like voltage, current, mV, thermocouple and RTD.
- User configurable signal conditioning for stable analog measurement.
- User defined engineering scaling for voltage, mV and current type of inputs.
- Easy troubleshooting with module level as well as channel level diagnostics.

These are non-isolated type of input channels.

Part Names

The figure below describes part names of the module.

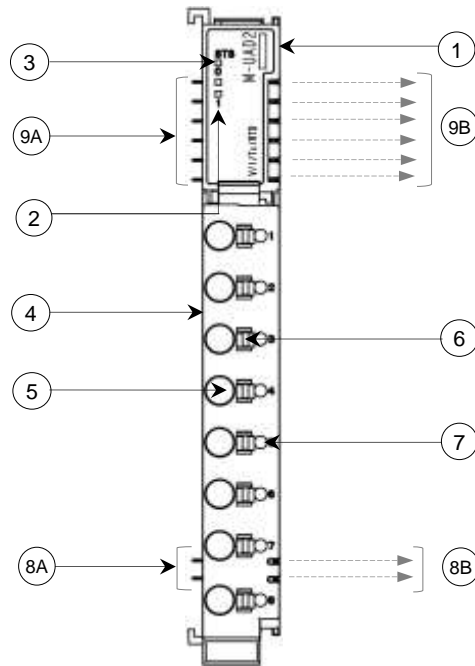

No.	Name	Description
1	M-UAD2	Module ordering code
2	IO LED Indication	0 and 1: 2, Green colour LEDs for individual input status
3	Module LED Indication	STS: 1, Bi-colour LED for module status
4	Terminal Block	8-point removable push type
5	IO Point	Wire insertion point for IO terminal.
6	Push Button	Press to release wire
7	Test Point	To measure signal voltage
8A	Field power supply Interface	2 Incoming pins for field power supply interface
8B		2 Outgoing pins for field power supply interface
9A	System power supply Interface	6 Incoming pins for system power supply interface
9B		6 Outgoing pins for system power supply interface

Specifications

The table below provides technical specifications of **M-UAD2**.

Specification	Description					
Ordering Code	M-UAD2					
Number of Input Channels	2 CH., universal, non-isolated, 16-bit resolution					
Input Types (user configurable)	Voltage	0 to 10 VDC, ± 10 VDC, ± 100 mV				
	Current	0 to 20 mA, 4 to 20 mA				
	RTD	3 Wire PT100 (385): -200°C to 850°C 3 Wire PT100 (385): -50°C to +250°C 3 Wire PT1000 (385): -50°C to +250°C				
	Thermocouple	J Type: -100°C to 1200°C K Type: -100°C to 1372°C				
Resolution and Overall Accuracy*	16 bits					
		Input Type	Basic Resolution	Basic Digital Output (Integer format)	Overall accuracy in % of FSD	
				25°C	60°C	
		0 to 10 VDC	0.15 mV	0 to 32000	± 0.2	± 0.3
		± 10 VDC	0.3 mV	-32000 to 32000	± 0.2	± 0.3
		± 100 mV	3 μ V	-32000 to 32000	± 0.1	± 0.2
		0 to 20 mA	0.3 μ A	0 to 32000	± 0.2	± 0.3
		4 to 20 mA	0.3 μ A	0 to 32000	± 0.2	± 0.3
		PT100	0.1°C	-2000 to 8500	± 0.3	± 0.6
		PT100	0.01°C	-5000 to 25000	± 0.5	± 1
		PT1000	0.01°C	-5000 to 25000	± 0.4	± 0.6
		J Type TC	0.1 °C	-1000 to 12000	± 1	± 1.5
	K Type TC	0.1 °C	-1000 to 13720	± 1	± 1.5	
ADC Conversion Type	Delta-sigma ($\Delta\Sigma$)					
Scaling to Engineering units	Supported for voltage, mV and current input types					
Absolute Maximum Input	± 30 VDC / ± 30 mA					
Lead Wire Resistance Compensation	30 Ω max. per wire (Applicable for 3-wire PT100, PT1000 input types)					
Input Impedance	Voltage input: 1 M Ω , Current input: 140 Ω , mV input: 100 K Ω					
Averaging	Number of averaging samples : 4, 8, 16 (Default), 32 User can configure averaging or digital filter at a time					
Digital Filter	1st order digital filter User configurable time constant: 10 msec to 5000 msec User can configure averaging or digital filter at a time					

*TC is the abbreviation of word Thermocouple.

M-UAD2 technical specifications are continued...

Specification		Description	
Module Updation Time		Module updation time = Channel 0 conversion time + Channel 1 conversion time*	
		The table below provides typical ADC conversion time for supported input types with Filter type setting as “No filter”.	
		Input Type	ADC Conversion time (msec)
		Voltage 0 to 10 V	50
		Voltage -10 to 10 V	
		Voltage -100 to 100 mV	
		Current 0 to 20 mA	
		Current 4 to 20 mA	
		PT100 -200°C to 850°C	
		PT100 -50°C to 250°C	100
		PT1000 -50°C to 250°C	
TC J Type -100°C to 1200°C	200		
TC K Type -100°C to 1372°C			
Sensor Excitation Current		1 mA for PT100 sensor input 0.25 mA for PT1000 sensor input	
Open Circuit Detection		For PT100 /PT1000, Thermocouple and 4 to 20 mA input types	
Channel Protection		PTC for over current protection of current input upto 70 mA	
Isolation	Input channel to internal circuit	1.5 KV, Optical	
	Input channel to input channel	No isolation	
	Field power supply to input channel	No isolation	
IO Memory Consumption	Input Words (IW)	2 Words	
	Diagnostics (SB) [User configurable]	3 Bytes	
System Power Supply Consumption		100 mA	
Field Power Supply Consumption		47 mA maximum at 24 VDC	
Terminal Block (Removable push type)		8-point	
Recommended Wire Size		0.5 sq. mm to 2.0 sq. mm (AWG 20 to 14), Solid wire or Stranded (flexible) wire with lugs	
Module Dimensions (H x W x D) in mm		105 x 13.2 x 83	

*Channel conversion time (averaging): ADC conversion time X number of averaging samples.
Channel conversion time (digital filter): ADC conversion time + (Time constant X 10).

NOTE

For PT100/ PT1000 input type, open circuit detection is supported for sensor connections. It is not supported for lead wire compensation input at terminal VIn-.

LED Indications

This section provides meaning of LED indications available on module.

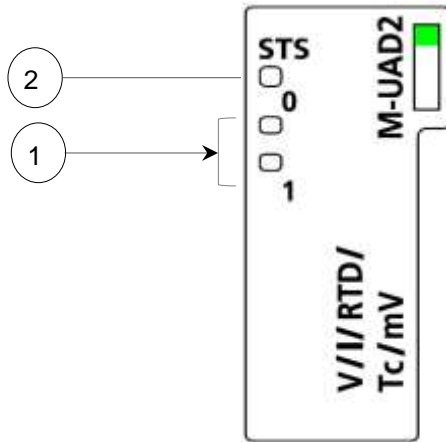

No.	*LED	Colour	Status	Description	
1	0, 1	Green	ON	Input channel is enabled.	
			Single flash	Following errors may occur on individual input channel. <ul style="list-style-type: none"> - Open circuit [Applicable for 4 to 20 mA, thermocouple inputs and PT100/PT1000 inputs] 	
			Double flash	Invalid configuration and parameterization.	
			OFF	Channel is disabled.	
2	STS	Bi-colour LED	None	Module is powered OFF.	
			Blue Green	ON	Module is powered ON and communicating with Header module.
				Single flash	Communication with Header is not established due to, <ul style="list-style-type: none"> - Module is powered ON and waiting for communication from Header. - Module mismatch.
			Red	ON	One of the following condition occurred. <ul style="list-style-type: none"> - Factory calibration error - ADC error - Hardware failure is detected on module.
				Single flash	One of the following condition occurred. <ul style="list-style-type: none"> - No communication from Header - Backplane bus fault detected.
			Yellow	ON	24 VDC field power supply is not available.

*For more details of LED indication states and flashing rates, refer section [Troubleshooting >> LED indications: States and flashing rates](#) in this manual.

Connection Diagram

This section provides wiring details for individual input channel. This module supports input types such as voltage, mV, current, RTD (PT100/ PT1000) and thermocouple. The figure below shows how to connect field sensors to module. Wiring description is provided on right side wall of the module.

For common wiring recommendations, refer section [Wiring](#).

The figures below shows various sensors connected to the terminals of module for example.

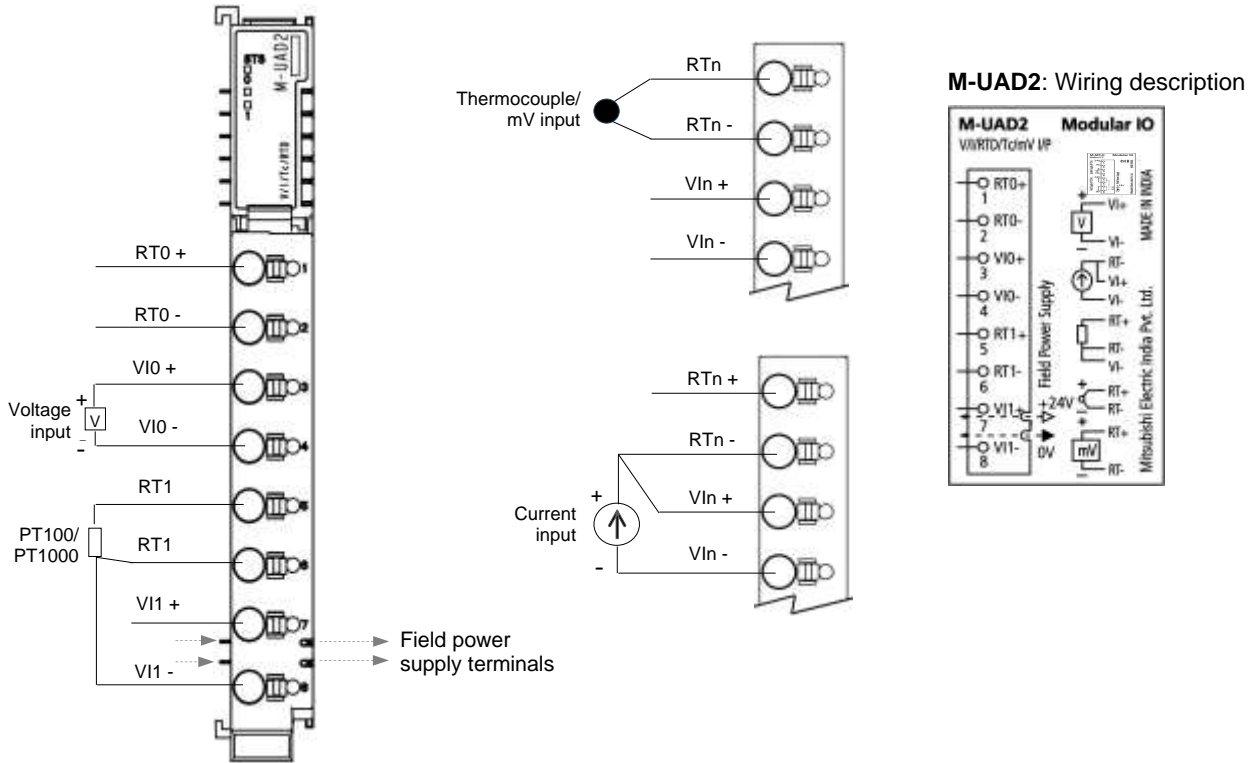

Following are the connection details for individual input type:

1. Voltage input is connected between **Vln+** and **Vln-**.
2. Current input is connected between **Vln-** and **RTn-**, along with short link between terminals **Vln+** and **RTn+**.
3. 3-wire PT100/ PT1000 sensor is connected between **RTn+** and **RTn-** along with lead compensation wire connected to **Vln-**.
4. Thermocouple/ mV input is connected between **RTn+** and **RTn-**.

Here, n is the input channel number 0 and 1.

NOTE

For M-UAD2, ambient temperature affects the overall accuracy of the module. So it is recommended to install analog input module away from modules dissipating heat e.g. M-DA2 as far as possible.

NOTE

For PT100/ PT1000 input type, open circuit detection is supported for sensor connections. It is not supported for lead wire compensation input at terminal Vln-.

For thermocouple and PT100/ PT1000 sensors, use cable provided or recommended by sensor manufacturer.

Connect cable shield directly to the good quality earth. It is recommended to keep cable shield at sensor end unconnected.

Use 2-core shielded twisted pair cable for carrying analog signal.

It is recommended to use thermocouple with isolated tip. Accuracy will be hampered if non isolated type of thermocouple element is used and if it gets connected to improper earth.

User Configurable Features

Module M-UAD2 provides user configurable features for all supported input types as shown below,

1. **Digital filter with user defined filter time constant settings.** [Range: 10 msec to 5000 msec].
 - It filters out spurious noise on analog input signal and ensures a stable analog count.
2. **Moving averaging with user definable number of samples.** [Number of samples : 4/ 8/ 16/ 32]
 - This feature is useful when an analog input signal is slowly varying or fluctuating.

User can either apply digital filter or moving average at a time.

3. **Engineering scaling units defined by minimum and maximum values.**

Module M-UAD2 provides user configurable engineering scaling in which channel data is scaled to engineering units defined by minimum and maximum values.

By default, Modular IO Configurator shows engineering scaling values as 0 and 100 for minimum and maximum value respectively.

For configuring user defined engineering scaling, set channel parameter Engineering scaling as **Enable**.

CH(n) Parameters*	Project Value	Comment
Engineering scaling	Enable	Enables / disables engineering scaling
	Disable [Default]	
Minimum Value	0 [Default] [Supported range: -32768 to 32767]	Minimum value for engineering scaling
Maximum Value	100 [Default] [Supported range: -32768 to 32767]	Maximum value for engineering scaling

*Here, n is the channel number.

Programmer can define Minimum Value and Maximum Value in terms of engineering units like speed of meters per minute, temperature in °C, air pressure in bar, etc.

4. **Open circuit detection is provided.** This feature is applicable for 4 to 20 mA range, thermocouple input and PT100/ PT1000 inputs.

User can set open circuit value as,

- 7FFFH [Default]
- 0
- Maximum value of range
- Minimum value of range

Refer section [Modular IO Configurator](#) for more details.

Parameters

IO module can be configured in modular IO station using Modular IO Configurator. For addition and removal of IO module, refer section [Modular IO Configurator](#).

User can set following parameters.

Parameter Name	Project Value	Comment
Share diagnostics	Enable [Default]	Enables diagnostic data (SB) sharing with header
	Disable	

Module diagnostic data and channel diagnostic data is available in Status Byte (SB) memory, if module parameter “Share diagnostics” is set to Enable.

The table below provides a list of channel parameters that user can set for individual input channel.

Parameter Name	Project Value	Comment
Enable	Yes [Default] No	Enables/ Disables channel
Input Type	Voltage 0 to 10 V [Default] Voltage -10 to +10 V Voltage -100mV to 100 mV Current 0 to 20 mA Current 4 to 20 mA PT100: -200 to 850°C PT100: -50 to 250°C PT1000: -50 to 250°C TC J Type: -100 to 1200°C TC K Type: -100 to 1372°C	Select input type
Filter type	Digital Filter [Default] No Filter Averaging	Select filtering type
Digital filter time constant	50 [Default]	Digital filter time constant (10 to 5000 msec)
Number of averaging samples	4 8 16 [Default] 32	Number of samples for averaging
Engineering Scaling	Disable [Default] Enable	Enable/ Disables engineering scaling
Minimum value	0 [Default] [Supported range: -32768 to 32767]	Minimum value for engineering scaling
Maximum value	100 [Default] [Supported range: -32768 to 32767]	Maximum value for engineering scaling
Open circuit value	7FFFH [Default] 0 Maximum value of range Minimum value of range	Channel data in case of open circuit

IO Data

Following table provides description for Analog input channel data.

Channel	Data Type	Local Address*
CH0	INT	IW n
CH1	INT	IW n+1

*Local address (n) value changes as per the slot position of IO module and configuration of modular IO station.

User can monitor the following diagnostics.

Channel	Data Type	Local Address*	Bit Status	Comment
Module Diagnostics	BYTE	SB n	--	--
No field power supply	BOOL	SB n.0	TRUE	24 VDC field power supply is not available.
			FALSE	24 VDC field power supply is available.
ADC fault	BOOL	SB n.1	TRUE	ADC is faulty.
			FALSE	ADC is healthy.
CJC error	BOOL	SB n.2	TRUE	CJC sensor onboard is faulty.
			FALSE	CJC sensor onboard is healthy.
Factory calibration error	BOOL	SB n.3	TRUE	Factory calibration data is invalid.
			FALSE	Factory calibration data is valid.
Reserved	BOOL	SB n.4	Reserved	
⋮	⋮	⋮	⋮	
Reserved	BOOL	SB n.7	Reserved	
Channel Diagnostics	BYTE	SB n+1	--	--
Channel enabled	BOOL	SB n+1.0	TRUE	If channel0 is enabled
			FALSE	If channel0 is disabled.
Channel open circuit	BOOL	SB n+1.1	TRUE	Sensor is disconnected when input type is current, thermocouple and RTD
			FALSE	Sensor is connected

For PT100/ PT1000 input type, open circuit is not detected, in case, lead compensation wire at terminal VIn- gets disconnected.

Module diagnostic data is available in Status Byte (SB) memory, if module parameter “Share diagnostics” is set to Enable.

Refer section [Troubleshooting](#) for station error code list and error messages.

7.2 M-AD4

[4 CH. Analog Voltage/ Current Input Module]

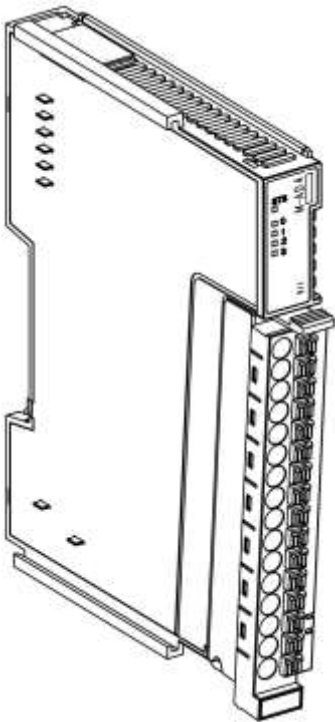

[Module Overview](#)

[Part Names](#)

[Specifications](#)

[LED Indications](#)

[Connection Diagram](#)

[User Configurable Features](#)

[Parameters](#)

[IO Data](#)

Module Overview

M-AD4 is 4 channel analog voltage/ current input module. Highlighting features are as below.

- Supports voltage and current input types.
- User configurable signal conditioning for stable analog measurement.
- User defined engineering scaling.
- Easy troubleshooting with module level as well as channel level diagnostics.

These are non-isolated type of input channels.

Part Names

The figure below describes part names of the module.

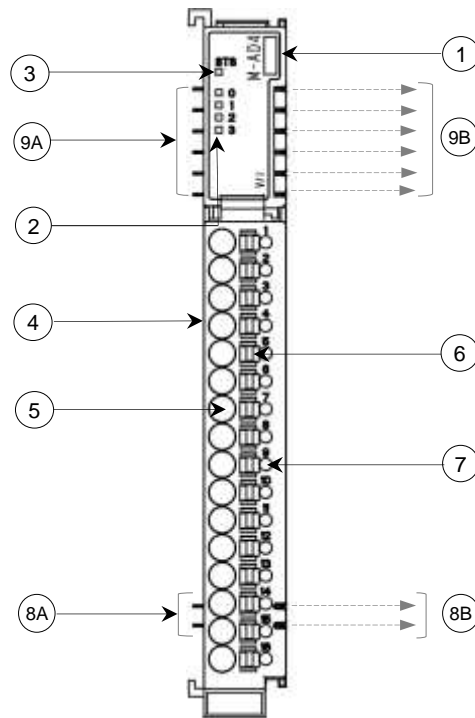

No.	Name	Description
1	M-AD4	Module ordering code
2	IO LED Indication	0 to 3: 4, Green colour LEDs for individual input status
3	Module LED Indication	STS: 1, Bi-colour LED for module status
4	Terminal Block	16-point removable push type
5	IO Point	Wire insertion point for IO terminal.
6	Push Button	Press to release wire
7	Test Point	To measure signal voltage
8A	Field power supply Interface	2 Incoming pins for field power supply interface
8B		2 Outgoing pins for field power supply interface
9A	System power supply Interface	6 Incoming pins for system power supply interface
9B		6 Outgoing pins for system power supply interface

Specifications

The table below provides technical specifications of **M-AD4**.

Specification	Description				
Ordering Code	M-AD4				
Number of Input Channels	4 CH., Voltage or current, non-isolated				
Input Types (user configurable)	Voltage	0 to 10V, -10 to 10V			
	Current	0 to 20mA, 4 to 20mA			
Resolution and Overall Accuracy	16 bits				
	Input Type	Resolution	Digital Output (Integer format)	Overall accuracy in % of FSD	
				25°C	60°C
	0 to 10V	0.3 mV	0 to 32000	±0.2	±0.3
	-10 to 10V	0.3 mV	-32000 to 32000	±0.2	±0.3
	0 to 20mA	0.6 µA	0 to 32000	±0.2	±0.3
4 to 20mA	0.6 µA	0 to 32000	±0.2	±0.3	
ADC Conversion Type	Delta-sigma ($\Delta\Sigma$)				
Scaling to Engineering units	Supported				
Absolute Maximum Input	±30 VDC / ±30 mA				
Input Impedance	Voltage input: 800 K Ω , Current input: 140 Ω ,				
Averaging	Number of averaging samples : 4, 8, 16 (Default), 32 User can configure averaging or digital filter at a time				
Digital Filter	1st order digital filter User configurable time constant: 5 msec (Default) to 5000 msec User can configure averaging or digital filter at a time				

NOTE

Module M-AD4 is supported in Modular IO Configurator Tool [V1.4.0.0] and Header firmware [V01.02.00.00] and onwards.

M-AD4 technical specifications are continued...

Specification		Description								
Module Update Time		<p>*Module update time [for Averaging]= Hardware Filter Time + [(ADC Conversion time X No. Of channels enabled) X Number Of Samples].</p> <p>*Module update time [for Digital Filter]= Hardware Filter Time + [(ADC Conversion time X No. Of channels enabled) + (Time Constant X 10)]</p> <p>The table below provides typical ADC conversion time.</p> <table border="1"> <thead> <tr> <th>Input Type</th> <th>ADC Conversion time (msec)</th> </tr> </thead> <tbody> <tr> <td>Voltage 0 to 10V</td> <td rowspan="2">2.1</td> </tr> <tr> <td>Voltage -10 to 10V</td> </tr> <tr> <td>Current 0 to 20mA</td> <td rowspan="2">4.2</td> </tr> <tr> <td>Current 4 to 20mA</td> </tr> </tbody> </table>	Input Type	ADC Conversion time (msec)	Voltage 0 to 10V	2.1	Voltage -10 to 10V	Current 0 to 20mA	4.2	Current 4 to 20mA
Input Type	ADC Conversion time (msec)									
Voltage 0 to 10V	2.1									
Voltage -10 to 10V										
Current 0 to 20mA	4.2									
Current 4 to 20mA										
Open Circuit Detection		For 4 to 20mA input types								
Channel Protection		PTC for over current protection of current input upto 70 mA								
Isolation	Input channel to internal circuit	1.5 KV, Optical								
	Input channel to input channel	No isolation								
	Field power supply to input channel	No isolation								
IO Memory Consumption	Input Words (IW)	4 Words								
	Diagnostics (SB) [User configurable]	2 Bytes								
System Power Supply Consumption		100 mA								
Field Power Supply Consumption		30 mA maximum at 24 VDC								
Terminal Block (Removable push type)		16-point								
Recommended Wire Size		0.5 to 1.0 sq. mm (AWG 20 to 16) Solid wire or Stranded (flexible) wire with lugs								
Module Dimensions (H x W x D) in mm		105 x 13.2 x 83								

*Hardware filter time is 20 msec.

LED Indications

This section provides meaning of LED indications available on module.

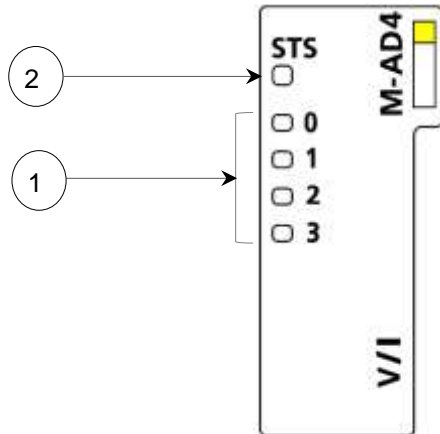

No.	*LED	Colour	Status	Description	
1	0 to 3	Green	ON	Input channel is enabled.	
			Single flash	Following errors may occur on individual input channel. - Open circuit [Applicable for 4 to 20 mA type input]	
			Double flash	Invalid configuration and parameterization.	
			OFF	Channel is disabled.	
2	STS	Bi-colour LED	None	Module is powered OFF.	
			Blue Green	ON	Module is powered ON and communicating with Header module.
				Single flash	Communication with Header is not established due to, - Module is powered ON and waiting for communication from Header. - Module mismatch.
			Red	ON	One of the following conditions occurred. - Factory calibration error - ADC error - Hardware failure is detected on module.
				Single flash	One of the following conditions occurred. - No communication from Header - Backplane bus fault detected
			Yellow	ON	24 VDC field power supply is not available.

*For more details of LED indication states and flashing rates, refer section [Troubleshooting >> LED indications: States and flashing rates](#) in this manual.

Connection Diagram

This section provides wiring details for individual input channel. This module supports voltage and current input types. The figure below shows how to connect field sensors to module. Wiring description is provided on right side wall of the module.

For common wiring recommendations, refer section [Wiring](#).

Example of voltage input for channel 0 and current input for channel 2.

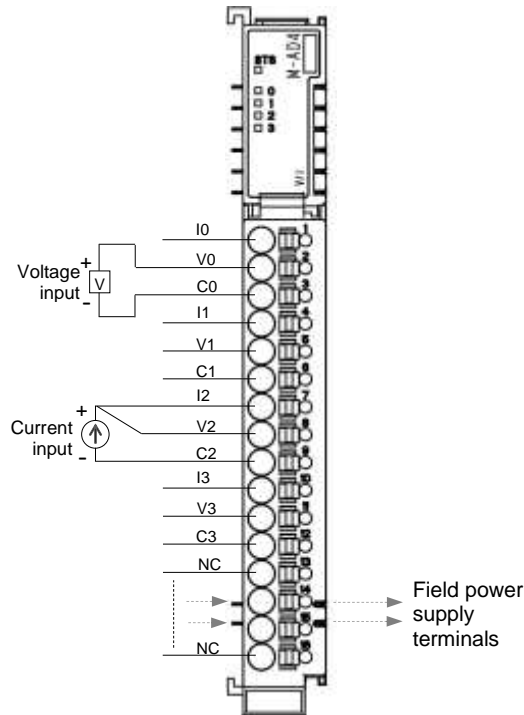

M-AD4: Wiring description

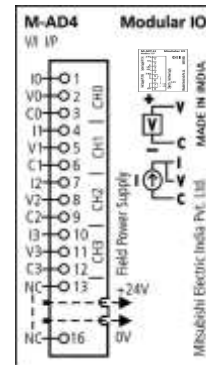

Following are the connection details for individual input type:

1. Voltage input is connected between **Vn** and **Cn**.
2. Current input is connected between **In** and **Cn**, along with short link between terminals **Vn** and **In**.

Here, n is the input channel number 0 to 3.

NOTE

For M-AD4, ambient temperature affects the overall accuracy of the module. So it is recommended to install analog input module away from modules dissipating heat e.g. M-DA2 as far as possible.

NOTE

Connect cable shield directly to the good quality earth. It is recommended to keep cable shield at sensor end unconnected.

Use 2-core shielded twisted pair cable for carrying analog signal.

User Configurable Features

Module M-AD4 provides user configurable features for all supported input types as shown below,

1. **Digital filter with user defined filter time constant settings.** [Range: 5 msec to 5000 msec].
 - It filters out spurious noise on analog input signal and ensures a stable analog count.
2. **Moving averaging with user definable number of samples.** [Number of samples : 4/ 8/ 16/ 32]
 - This feature is useful when an analog input signal is slowly varying or fluctuating.

User can either apply digital filter or moving average at a time.

3. **Engineering scaling units defined by minimum and maximum values.**

Module M-AD4 provides user configurable engineering scaling in which channel data is scaled to engineering units defined by minimum and maximum values.

By default, Modular IO Configurator shows engineering scaling values as 0 and 100 for minimum and maximum value respectively.

For configuring user defined engineering scaling, set channel parameter Engineering scaling as **Enable**.

CH(n) Parameters*	Project Value	Comment
Engineering scaling	Enable	Enables / disables engineering scaling
	Disable [Default]	
Minimum Value	0 [Default] [Supported range: -32768 to 32767]	Minimum value for engineering scaling
Maximum Value	100 [Default] [Supported range: -32768 to 32767]	Maximum value for engineering scaling

*Here, n is the channel number.

Programmer can define Minimum Value and Maximum Value in terms of engineering units like speed of meters per minute, air pressure in bar, etc

4. **Open circuit detection is provided.** This feature is applicable only for 4 to 20 mA range.

User can set open circuit value as,

- 7FFFH [Default]
- 0
- Maximum value of range
- Minimum value of range

Refer section [Modular IO Configurator](#) for more details.

Parameters

IO module can be configured in modular IO station using Modular IO Configurator. For addition and removal of IO module, refer section [Modular IO Configurator](#).

User can set following parameters.

Parameter Name	Project Value	Comment
Share diagnostics	Enable [Default]	Enables diagnostic data (SB) sharing with header
	Disable	
Update time IW (msec)	10	Defines time interval of input data exchange (3 to 500 msec)

Module diagnostic data and channel diagnostic data is available in Status Byte (SB) memory, if module parameter “Share diagnostics” is set to Enable.

The table below provides a list of channel parameters that user can set for individual input channel.

Parameter Name	Project Value	Comment
Enable	Yes [Default] No	Enables/ disables channel
Input Type	Voltage 0 to 10V [Default] Voltage -10 to +10V Current 0 to 20mA Current 4 to 20mA	Select input type
Filter type	No Filter Averaging Digital Filter [Default]	Select filtering type
Digital filter time constant	5 [Default]	Digital filter time constant (5 to 5000msec)
Number of averaging samples	4 8 16 [Default] 32	Number of samples for averaging
Engineering Scaling	Disable [Default] Enable	Enable/ disables engineering scaling
Minimum value	0 [Default] [Supported range: -32768 to 32767]	Minimum value for engineering scaling
Maximum value	100 [Default] [Supported range: -32768 to 32767]	Maximum value for engineering scaling
Open circuit value	7FFFH [Default] 0 Maximum value of range Minimum value of range	Channel data in case of open circuit

IO Data

Following table provides description for Analog input channel data.

Channel	Data Type	Local Address*
CH0	INT	IW n
CH1	INT	IW n+1
CH2	INT	IW n+2
CH3	INT	IW n+3

*Local address (n) value changes as per the slot position of IO module and configuration of modular IO station.

User can monitor the following diagnostics.

Channel	Data Type	Local Address*	Bit Status	Comment
Module Diagnostics				
Module Diagnostics	BYTE	SB n	--	--
No field power supply	BOOL	SB n.0	TRUE	24 VDC field power supply is not available.
			FALSE	24 VDC field power supply is available.
ADC fault	BOOL	SB n.1	TRUE	ADC section is faulty.
			FALSE	ADC section is healthy.
Factory calibration error	BOOL	SB n.2	TRUE	Factory calibration data is invalid.
			FALSE	Factory calibration data is valid.
Reserved	BOOL	SB n.3	Reserved	
⋮	⋮	⋮	⋮	
Reserved	BOOL	SB n.7	Reserved	
Channel Diagnostics				
Channel Diagnostics	BYTE	SB n+1	--	--
Channel 0 enabled	BOOL	SB n+1.0	TRUE	If channel 0 is enabled
			FALSE	If channel 0 is disabled.
Channel 0 open circuit	BOOL	SB n+1.1	TRUE	Sensor is disconnected when input type is current
			FALSE	Sensor is connected
Channel 1 enabled	BOOL	SB n+1.2	TRUE	If channel 1 is enabled
			FALSE	If channel 1 is disabled.
Channel 1 open circuit	BOOL	SB n+1.3	TRUE	Sensor is disconnected when input type is current
			FALSE	Sensor is connected
Channel 2 enabled	BOOL	SB n+1.4	TRUE	If channel 2 is enabled
			FALSE	If channel 2 is disabled.
Channel 2 open circuit	BOOL	SB n+1.5	TRUE	Sensor is disconnected when input type is current
			FALSE	Sensor is connected
Channel 3 enabled	BOOL	SB n+1.6	TRUE	If channel 3 is enabled
			FALSE	If channel 3 is disabled.
Channel 3 open circuit	BOOL	SB n+1.7	TRUE	Sensor is disconnected when input type is current
			FALSE	Sensor is connected

Module diagnostic and channel diagnostic data is available in Status Byte (SB) memory, if module parameter “Share diagnostics” is set to **Enable**. Refer section [Troubleshooting](#) for station error code list and error messages.

7.3 M-ADV8

[8 CH. Analog Voltage Input Module]

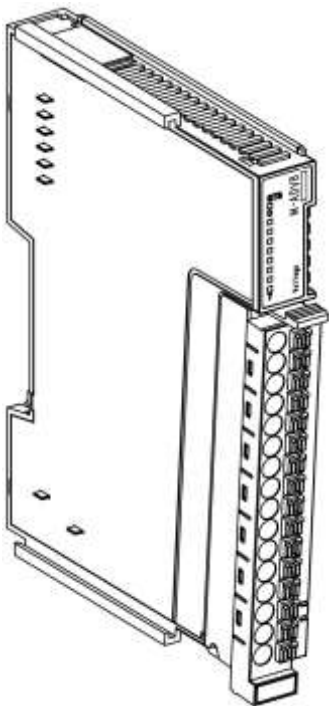

[Module Overview](#)

[Part Names](#)

[Specifications](#)

[LED Indications](#)

[Connection Diagram](#)

[User Configurable Features](#)

[Parameters](#)

[IO Data](#)

Module Overview

M-ADV8 is 8 channel analog voltage input module. Highlighting features are as below.

- Individual channel supports voltage input types 0 to 5V, 0 to 10V and -10 to 10V.
- User configurable signal conditioning for stable analog measurement.
- User configurable functions such as engineering scaling, reduces PLC application development.
- LED indications for module as well as channel status.

These are non-isolated type of input channels.

Part Names

The figure below describes part names of the module.

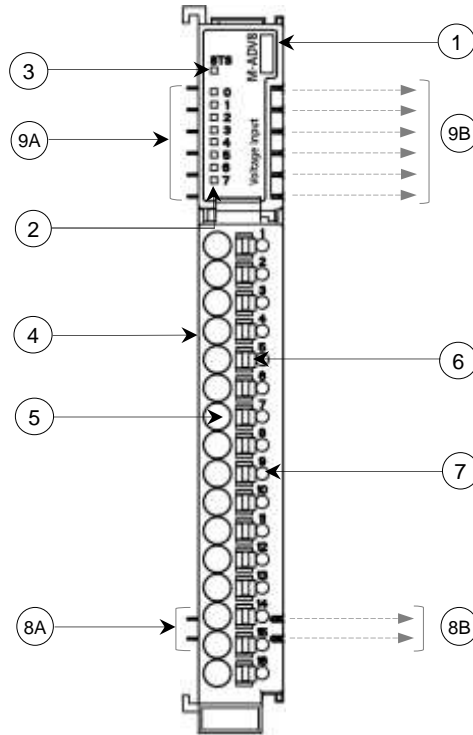

No.	Name	Description
1	M-ADV8	Module ordering code
2	IO LED Indication	0 to 7: 8, Green colour LEDs for individual input status
3	Module LED Indication	STS: 1, Bi-colour LED for module status
4	Terminal Block	16-point removable push type
5	IO Point	Wire insertion point for IO terminal.
6	Push Button	Press to release wire
7	Test Point	To measure signal voltage
8A	Field power supply Interface	2 Incoming pins for field power supply interface
8B		2 Outgoing pins for field power supply interface
9A	System power supply Interface	6 Incoming pins for system power supply interface
9B		6 Outgoing pins for system power supply interface

Specifications

The table below provides technical specifications of **M-ADV8**.

Specification		Description				
Ordering Code		M-ADV8				
Number of Input Channels		8 CH., Voltage, non-isolated				
Input Types (user configurable)		Voltage	0 to 10V [Default], -10 to 10V, 0 to 5V			
Resolution and Overall Accuracy		16 bits				
		Input Type	Resolution	Digital Output (Integer format)	Overall accuracy in % of FSD	
					25°C	60°C
		0 to 10V	0.3 mV	0 to 32000	±0.2	±0.3
		-10 to 10V	0.3 mV	-32000 to 32000	±0.2	±0.3
	0 to 5V	0.156 mV	0 to 32000	±0.2	±0.3	
ADC Conversion Type		Delta-sigma ($\Delta\Sigma$)				
Scaling to Engineering units		Supported				
Absolute Maximum Input		±30 VDC				
Input Impedance		Voltage input: 500 K Ω				
Averaging		Number of averaging samples: 4, 8, 16 (Default), 32 User can configure averaging or digital filter at a time				
Digital Filter		1st order digital filter User configurable time constant: 5 msec (Default) to 5000 msec User can configure averaging or digital filter at a time				
Module Updation Time		* Module updation time [for Averaging]= Hardware Filter Time + [(ADC Conversion time X No. Of channels enabled) X Number Of Samples].				
		* Module updation time [for Digital Filter]= Hardware Filter Time + [(ADC Conversion time X No. Of channels enabled) + (Time Constant X 5)]				
		The table below provides typical ADC conversion time.				
		Input Type	ADC Conversion time (msec)			
		Voltage 0 to 10V	1.2			
Voltage -10 to 10V						
Voltage 0 to 5V						
Isolation	Input channel to internal circuit	1.5 KV, Optical				
	Input channel to input channel	No isolation				
	Field power supply to input channel	No isolation				
IO Memory Consumption	Input Words (IW)	8 Words				
	Diagnostics (SB) [User configurable]	3 Bytes				

M-ADV8 technical specifications are continued...

Specification	Description
System Power Supply Consumption	100 mA
Field Power Supply Consumption	30 mA maximum at 24 VDC
5VDC Backplane Current Consumption	135 mA
Terminal Block (Removable push type)	16-point
Recommended Wire Size	0.5 to 1.0 sq. mm (AWG 20 to 16) Solid wire or Stranded (flexible) wire with lugs
Module Dimensions (H x W x D) in mm	105 x 13.2 x 83

*Hardware filter time is 25 msec.

NOTE

Module M-ADV8 is supported in Modular IO Configurator Tool [V1.6.0.0] onwards.

Additional input range of 0 to 5VDC, for M-ADV8 module, is supported in Modular IO Configurator Tool [V1.10.0.0] onwards.

LED Indications

This section provides meaning of LED indications available on module.

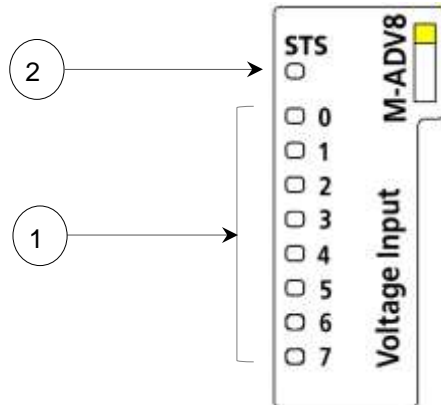

No.	*LED	Colour	Status	Description	
1	0 to 7	Green	ON	Input channel is enabled.	
			Double flash	Invalid configuration and parameterization.	
			OFF	Input channel is disabled.	
2	STS	Bi-colour LED	None	Module is powered OFF.	
			Blue Green	ON	Module is powered ON and communicating with Header module.
				Single flash	Communication with Header is not established due to, <ul style="list-style-type: none"> - Module is powered ON and waiting for communication from Header. - Module mismatch.
			Red	ON	One of the following conditions occurred. <ul style="list-style-type: none"> - Factory calibration error - ADC error - Hardware failure is detected on module.
				Single flash	One of the following conditions occurred. <ul style="list-style-type: none"> - No communication from Header - Backplane bus fault detected
			Yellow	ON	24 VDC field power supply is not available.

*For more details of LED indication states and flashing rates, refer section [Troubleshooting >> LED indications: States and flashing rates](#) in this manual.

Connection Diagram

This section provides wiring details for individual input channel. This module supports voltage input types. The figure below shows how to connect field sensors to module. Wiring description is provided on right side wall of the module.

For common wiring recommendations, refer section [Wiring](#).

Example of voltage input for channel 0 and channel 4.

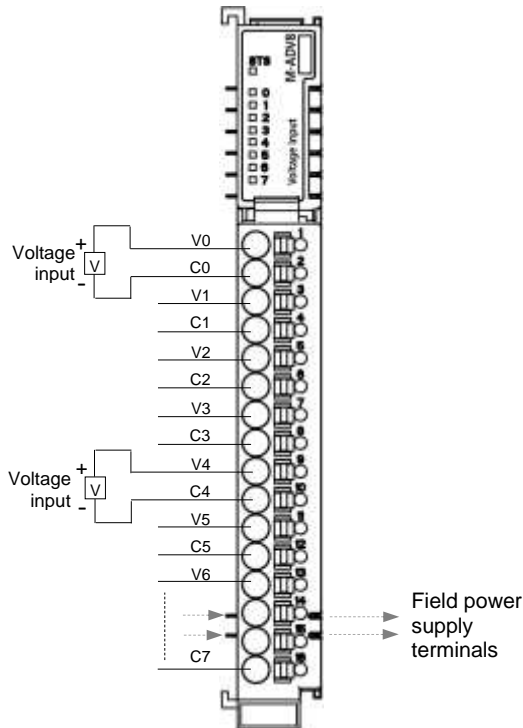

M-ADV8: Wiring description

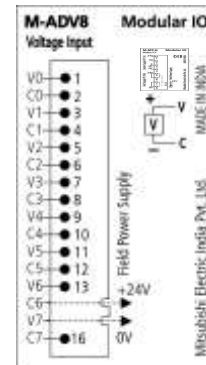

Following are the connection details for individual input type:

1. Voltage input is connected between **V_n** and **C_n**.

Here, n is the input channel number 0 to 7.

NOTE

For M-ADV8, ambient temperature affects the overall accuracy of the module. So, it is recommended to install analog input module away from modules dissipating heat e.g. M-DA2 as far as possible.

NOTE

Connect cable shield directly to the good quality earth. It is recommended to keep cable shield at sensor end unconnected.

Use 2-core shielded twisted pair cable for carrying analog signal.

User Configurable Features

Module M-ADV8 provides user configurable features for voltage input types as shown below,

1. **Digital filter with user defined filter time constant settings.** [Range: 5 msec to 5000 msec].
 - It filters out spurious noise on analog input signal and ensures a stable analog count.
2. **Moving averaging with user definable number of samples.** [Number of samples: 4/ 8/ 16/ 32]
 - This feature is useful when an analog input signal is slowly varying or fluctuating.

User can either apply digital filter or moving average at a time.

3. **Engineering scaling units defined by minimum and maximum values.**

Module M-ADV8 provides user configurable engineering scaling in which channel data is scaled to engineering units defined by minimum and maximum values.

By default, Modular IO Configurator shows engineering scaling values as 0 and 100 for minimum and maximum value respectively.

For configuring user defined engineering scaling, set channel parameter Engineering scaling as **Enable**.

CH(n) Parameters*	Project Value	Comment
Engineering scaling	Enable	Enables / disables engineering scaling
	Disable [Default]	
Minimum Value	0 [Default] [Supported range: -32768 to 32767]	Minimum value for engineering scaling
Maximum Value	100 [Default] [Supported range: -32768 to 32767]	Maximum value for engineering scaling

*Here, n is the channel number.

Programmer can define Minimum Value and Maximum Value in terms of engineering units like speed of meters per minute, air pressure in bar, etc.

Refer section [Modular IO Configurator](#) for more details.

Parameters

IO module can be configured in modular IO station using Modular IO Configurator. For addition and removal of IO module, refer section [Modular IO Configurator](#).

User can set following parameters.

Parameter Name	Project Value	Comment
Share diagnostics	Enable [Default]	Enables diagnostic data (SB) sharing with header
	Disable	
Update time IW (msec)	10	Defines time interval of input data exchange (3 to 500 msec)

Module diagnostic data and channel diagnostic data is available in Status Byte (SB) memory, if module parameter “Share diagnostics” is set to Enable.

The table below provides a list of channel parameters that user can set for individual input channel.

Parameter Name	Project Value	Comment
Enable	Yes [Default] No	Enables/ disables channel
Input Type	Voltage 0 to 10V [Default] Voltage -10 to +10V Voltage 0 to 5V	Select input type
Filter type	No Filter Averaging Digital Filter [Default]	Select filtering type
Digital filter time constant	10 [Default]	Digital filter time constant (5 to 5000 msec)
Number of averaging samples	4 8 16 [Default] 32	Number of samples for averaging
Engineering Scaling	Disable [Default] Enable	Enable/ disables engineering scaling
Minimum value	0 [Default] [Supported range: -32768 to 32767]	Minimum value for engineering scaling
Maximum value	100 [Default] [Supported range: -32768 to 32767]	Maximum value for engineering scaling

IO Data

Following table provides description for Analog input channel data.

Channel	Data Type	Local Address*
CH0	INT	IW n
CH1	INT	IW n+1
CH2	INT	IW n+2
CH3	INT	IW n+3
CH4	INT	IW n+4
CH5	INT	IW n+5
CH6	INT	IW n+6
CH7	INT	IW n+7

*Local address (n) value changes as per the slot position of IO module and configuration of modular IO station.

User can monitor the following diagnostics.

Channel	Data Type	Local Address*	Bit Status	Comment
Module Diagnostics	BYTE	SB n	--	--
No field power supply	BOOL	SB n.0	TRUE	24 VDC field power supply is not available.
			FALSE	24 VDC field power supply is available.
ADC fault	BOOL	SB n.1	TRUE	ADC section is faulty.
			FALSE	ADC section is healthy.
Factory calibration error	BOOL	SB n.2	TRUE	Factory calibration data is invalid.
			FALSE	Factory calibration data is valid.
Reserved	BOOL	SB n.3	Reserved	
⋮	⋮	⋮	⋮	
Reserved	BOOL	SB n.7	Reserved	
Channel Diagnostics	WORD	SB n+1 – SB n+2	--	--
Channel 0 enabled	BOOL	SB n+1.0	TRUE	If channel 0 is enabled
			FALSE	If channel 0 is disabled.
Reserved	BOOL	SB n+1.1	Reserved	
Channel 1 enabled	BOOL	SB n+1.2	TRUE	If channel 1 is enabled
			FALSE	If channel 1 is disabled.
Reserved	BOOL	SB n+1.3	Reserved	
Channel 2 enabled	BOOL	SB n+1.4	TRUE	If channel 2 is enabled
			FALSE	If channel 2 is disabled.
Reserved	BOOL	SB n+1.5	Reserved	
Channel 3 enabled	BOOL	SB n+1.6	TRUE	If channel 3 is enabled
			FALSE	If channel 3 is disabled.
Reserved	BOOL	SB n+1.7	Reserved	

Channel 4 enabled	BOOL	SB n+2.0	TRUE	If channel 4 is enabled
			FALSE	If channel 4 is disabled.
Reserved	BOOL	SB n+2.1	Reserved	
Channel 5 enabled	BOOL	SB n+2.2	TRUE	If channel 5 is enabled
			FALSE	If channel 5 is disabled.
Reserved	BOOL	SB n+2.3	Reserved	
Channel 6 enabled	BOOL	SB n+2.4	TRUE	If channel 6 is enabled
			FALSE	If channel 6 is disabled.
Reserved	BOOL	SB n+2.5	Reserved	
Channel 7 enabled	BOOL	SB n+2.6	TRUE	If channel 7 is enabled
			FALSE	If channel 7 is disabled.
Reserved	BOOL	SB n+2.7	Reserved	

Module diagnostic and channel diagnostic data is available in Status Byte (SB) memory, if module parameter “Share diagnostics” is set to **Enable**.

Refer section [Troubleshooting](#) for station error code list and error messages.

7.4 M-ADI8

[8 CH. Analog Current Input Module]

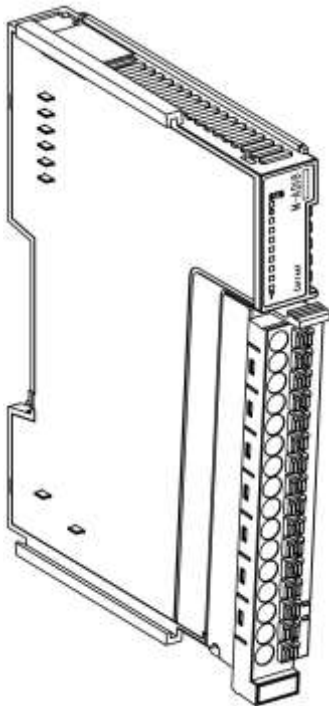

[Module Overview](#)

[Part Names](#)

[Specifications](#)

[LED Indications](#)

[Connection Diagram](#)

[User Configurable Features](#)

[Parameters](#)

[IO Data](#)

Module Overview

M-ADI8 is 8 channel analog current input module. Highlighting features are as below.

- Individual channel supports current input types 0 to 20mA and 4 to 20mA.
- User configurable signal conditioning for stable analog measurement.
- User configurable functions such as engineering scaling, reduces PLC application development.
- Easy troubleshooting with module level as well as channel level diagnostics.
- LED indications for module as well as channel status.

These are non-isolated type of input channels.

Part Names

The figure below describes part names of the module.

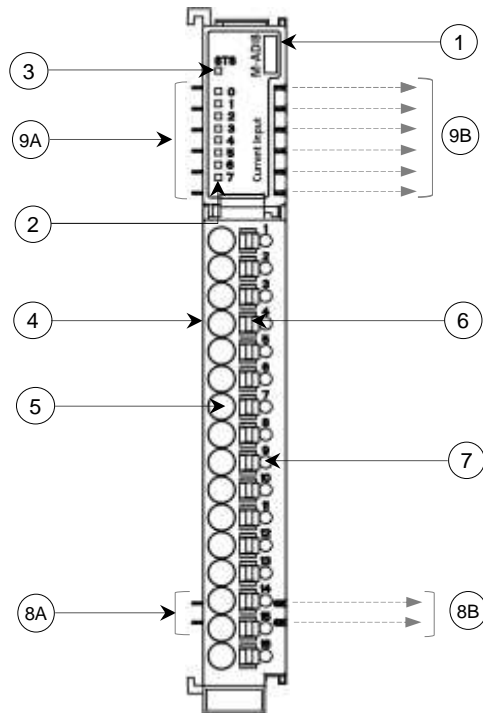

No.	Name	Description
1	M-ADI8	Module ordering code
2	IO LED Indication	0 to 3: 4, Green colour LEDs for individual input status
3	Module LED Indication	STS: 1, Bi-colour LED for module status
4	Terminal Block	16-point removable push type
5	IO Point	Wire insertion point for IO terminal.
6	Push Button	Press to release wire
7	Test Point	To measure signal voltage
8A	Field power supply Interface	2 Incoming pins for field power supply interface
8B		2 Outgoing pins for field power supply interface
9A	System power supply Interface	6 Incoming pins for system power supply interface
9B		6 Outgoing pins for system power supply interface

Specifications

The table below provides technical specifications of **M-ADI8**.

Specification		Description				
Ordering Code		M-ADI8				
Number of Input Channels		8CH., Current, non-isolated				
Input Types (user configurable)		Current	0 to 20mA [Default], 4 to 20mA			
Resolution and Overall Accuracy		16 bits				
		Input Type	Resolution	Digital Output (Integer format)	Overall accuracy in % of FSD	
					25°C	60°C
		0 to 20mA	0.6 μ A	0 to 32000	\pm 0.25	\pm 0.4
	4 to 20mA	0.6 μ A	0 to 32000	\pm 0.25	\pm 0.4	
ADC Conversion Type		Delta-sigma ($\Delta\Sigma$)				
Scaling to Engineering units		Supported				
Absolute Maximum Input		\pm 30 mA				
Input Impedance		Current input: 135 Ω				
Averaging		Number of averaging samples: 4, 8, 16 (Default), 32 User can configure averaging or digital filter at a time				
Digital Filter		1st order digital filter User configurable time constant: 5 msec (Default) to 5000 msec User can configure averaging or digital filter at a time				
Module Updation Time		* Module updation time [for Averaging]= Hardware Filter Time + [(ADC Conversion time X No. Of channels enabled) X Number Of Samples].				
		* Module updation time [for Digital Filter]= Hardware Filter Time + [(ADC Conversion time X No. Of channels enabled) + (Time Constant X 5)]				
		The table below provides typical ADC conversion time.				
			Input Type	ADC Conversion time (msec)		
	Current 0 to 20mA	12.5				
	Current 4 to 20mA					
Open Circuit Detection		For 4 to 20mA input types				
Channel Protection		PTC for over current protection of current input up to 70 mA				
Isolation	Input channel to internal circuit	1.5 KV, Optical				
	Input channel to input channel	No isolation				
	Field power supply to input channel	No isolation				
IO Memory Consumption	Input Words (IW)	8 Words				
	Diagnostics (SB) [User configurable]	3 Bytes				

M-ADI8 technical specifications are continued...

Specification	Description
System Power Supply Consumption	100 mA
Field Power Supply Consumption	30 mA maximum at 24 VDC
5VDC Backplane Current Consumption	135 mA
Terminal Block (Removable push type)	16-point
Recommended Wire Size	0.5 to 1.0 sq. mm (AWG 20 to 16) Solid wire or Stranded (flexible) wire with lugs
Module Dimensions (H x W x D) in mm	105 x 13.2 x 83

*Hardware filter time is 5 msec.

NOTE

Module M-ADI8 is supported in Modular IO Configurator Tool [V1.6.0.0] and Header firmware [V01.02.00.00] and onwards.

LED Indications

This section provides meaning of LED indications available on module.

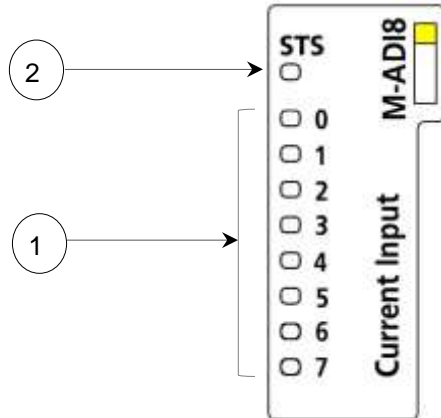

No.	*LED	Colour	Status	Description	
1	0 to 7	Green	ON	Input channel is enabled.	
			Single flash	Following errors may occur on individual input channel. - Open circuit [Applicable for 4 to 20 mA type input]	
			Double flash	Invalid configuration and parameterization.	
			OFF	Channel is disabled.	
2	STS	Bi-colour LED	None	Module is powered OFF.	
			Blue Green	ON	Module is powered ON and communicating with Header module.
				Single flash	Communication with Header is not established due to, - Module is powered ON and waiting for communication from Header. - Module mismatch.
			Red	ON	One of the following conditions occurred. - Factory calibration error - ADC error - Hardware failure is detected on module.
				Single flash	One of the following conditions occurred. - No communication from Header - Backplane bus fault detected
Yellow	ON	24 VDC field power supply is not available.			

*For more details of LED indication states and flashing rates, refer section [Troubleshooting >> LED indications: States and flashing rates](#) in this manual.

Connection Diagram

This section provides wiring details for individual input channel. This module supports current input types. The figure below shows how to connect field sensors to module. Wiring description is provided on right side wall of the module.

For common wiring recommendations, refer section [Wiring](#).

Example of current input for channel 0 and channel 4.

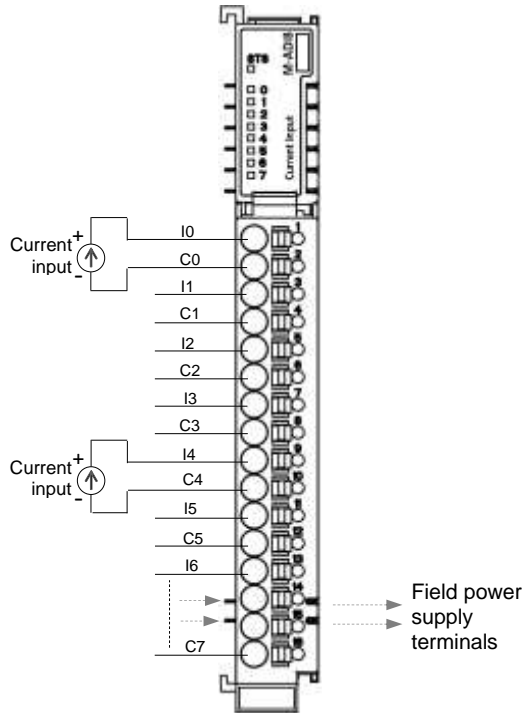

M-ADI8: Wiring description

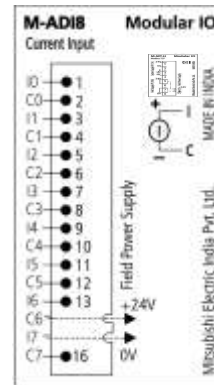

Following are the connection details for individual input type:

1. Current input is connected between **In** and **Cn**.

Here, n is the input channel number 0 to 7.

NOTE

For M-ADI8, ambient temperature affects the overall accuracy of the module. So, it is recommended to install analog input module away from modules dissipating heat e.g. M-DA2 as far as possible.

NOTE

Connect cable shield directly to the good quality earth. It is recommended to keep cable shield at sensor end unconnected.

Use 2-core shielded twisted pair cable for carrying analog signal.

User Configurable Features

Module M-AD18 provides user configurable features for all supported input types as shown below,

1. **Digital filter with user defined filter time constant settings.** [Range: 5 msec to 5000 msec].
 - It filters out spurious noise on analog input signal and ensures a stable analog count.
2. **Moving averaging with user definable number of samples.** [Number of samples: 4/ 8/ 16/ 32]
 - This feature is useful when an analog input signal is slowly varying or fluctuating.

User can either apply digital filter or moving average at a time.

3. **Engineering scaling units defined by minimum and maximum values.**

Module M-AD18 provides user configurable engineering scaling in which channel data is scaled to engineering units defined by minimum and maximum values.

By default, Modular IO Configurator shows engineering scaling values as 0 and 100 for minimum and maximum value respectively.

For configuring user defined engineering scaling, set channel parameter Engineering scaling as **Enable**.

CH(n) Parameters*	Project Value	Comment
Engineering scaling	Enable	Enables / disables engineering scaling
	Disable [Default]	
Minimum Value	0 [Default] [Supported range: -32768 to 32767]	Minimum value for engineering scaling
Maximum Value	100 [Default] [Supported range: -32768 to 32767]	Maximum value for engineering scaling

*Here, n is the channel number.

Programmer can define Minimum Value and Maximum Value in terms of engineering units like speed of meters per minute, air pressure in bar, etc.

4. **Open circuit detection is provided.** This feature is applicable only for 4 to 20 mA range.

User can set open circuit value as,

- 7FFFH [Default]
- 0
- Maximum value of range
- Minimum value of range

Refer section [Modular IO Configurator](#) for more details.

Parameters

IO module can be configured in modular IO station using Modular IO Configurator. For addition and removal of IO module, refer section [Modular IO Configurator](#).

User can set following parameters.

Parameter Name	Project Value	Comment
Share diagnostics	Enable [Default]	Enables diagnostic data (SB) sharing with header
	Disable	
Update time IW (msec)	10	Defines time interval of input data exchange (3 to 500 msec)

Module diagnostic data and channel diagnostic data is available in Status Byte (SB) memory, if module parameter "Share diagnostics" is set to Enable.

The table below provides a list of channel parameters that user can set for individual input channel.

Parameter Name	Project Value	Comment
Enable	Yes [Default] No	Enables/ disables channel
Input Type	Current 0 to 20mA [Default] Current 4 to 20mA	Select input type
Filter type	No Filter Averaging Digital Filter [Default]	Select filtering type
Digital filter time constant	10 [Default]	Digital filter time constant (5 to 5000msec)
Number of averaging samples	4 8 16 [Default] 32	Number of samples for averaging
Engineering Scaling	Disable [Default] Enable	Enable/ disables engineering scaling
Minimum value	0 [Default] [Supported range: -32768 to 32767]	Minimum value for engineering scaling
Maximum value	100 [Default] [Supported range: -32768 to 32767]	Maximum value for engineering scaling
Open circuit value	7FFFH [Default] 0 Maximum value of range Minimum value of range	Channel data in case of open circuit

IO Data

Following table provides description for Analog input channel data.

Channel	Data Type	Local Address*
CH0	INT	IW n
CH1	INT	IW n+1
CH2	INT	IW n+2
CH3	INT	IW n+3
CH4	INT	IW n+4
CH5	INT	IW n+5
CH6	INT	IW n+6
CH7	INT	IW n+7

*Local address (n) value changes as per the slot position of IO module and configuration of modular IO station.

User can monitor the following diagnostics.

Channel	Data Type	Local Address*	Bit Status	Comment
Module Diagnostics	BYTE	SB n	--	--
No field power supply	BOOL	SB n.0	TRUE	24 VDC field power supply is not available.
			FALSE	24 VDC field power supply is available.
ADC fault	BOOL	SB n.1	TRUE	ADC section is faulty.
			FALSE	ADC section is healthy.
Factory calibration error	BOOL	SB n.2	TRUE	Factory calibration data is invalid.
			FALSE	Factory calibration data is valid.
Reserved	BOOL	SB n.3	Reserved	
⋮	⋮	⋮	⋮	
Reserved	BOOL	SB n.7	Reserved	
Channel Diagnostics	BYTE	SB n+1 – SB n+2	--	--
Channel 0 enabled	BOOL	SB n+1.0	TRUE	If channel 0 is enabled
			FALSE	If channel 0 is disabled.
Channel 0 open circuit	BOOL	SB n+1.1	TRUE	Sensor is disconnected when input type is current
			FALSE	Sensor is connected
Channel 1 enabled	BOOL	SB n+1.2	TRUE	If channel 1 is enabled
			FALSE	If channel 1 is disabled.
Channel 1 open circuit	BOOL	SB n+1.3	TRUE	Sensor is disconnected when input type is current
			FALSE	Sensor is connected
Channel 2 enabled	BOOL	SB n+1.4	TRUE	If channel 2 is enabled
			FALSE	If channel 2 is disabled.
Channel 2 open circuit	BOOL	SB n+1.5	TRUE	Sensor is disconnected when input type is current
			FALSE	Sensor is connected

Channel 3 enabled	BOOL	SB n+1.6	TRUE	If channel 3 is enabled
			FALSE	If channel 3 is disabled.
Channel 3 open circuit	BOOL	SB n+1.7	TRUE	Sensor is disconnected when input type is current
			FALSE	Sensor is connected
Channel 4 enabled	BOOL	SB n+2.0	TRUE	If channel 4 is enabled
			FALSE	If channel 4 is disabled.
Channel 4 open circuit	BOOL	SB n+2.1	TRUE	Sensor is disconnected when input type is current
			FALSE	Sensor is connected
Channel 5 enabled	BOOL	SB n+2.2	TRUE	If channel 5 is enabled
			FALSE	If channel 5 is disabled.
Channel 5 open circuit	BOOL	SB n+2.3	TRUE	Sensor is disconnected when input type is current
			FALSE	Sensor is connected
Channel 6 enabled	BOOL	SB n+2.4	TRUE	If channel 6 is enabled
			FALSE	If channel 6 is disabled.
Channel 6 open circuit	BOOL	SB n+2.5	TRUE	Sensor is disconnected when input type is current
			FALSE	Sensor is connected
Channel 7 enabled	BOOL	SB n+2.6	TRUE	If channel 7 is enabled
			FALSE	If channel 7 is disabled.
Channel 7 open circuit	BOOL	SB n+2.7	TRUE	Sensor is disconnected when input type is current
			FALSE	Sensor is connected

Module diagnostic and channel diagnostic data is available in Status Byte (SB) memory, if module parameter “Share diagnostics” is set to **Enable**.

Refer section [Troubleshooting](#) for station error code list and error messages.

7.5 M-TCRT4

[4 CH. Thermocouple/ RTD Input Module]

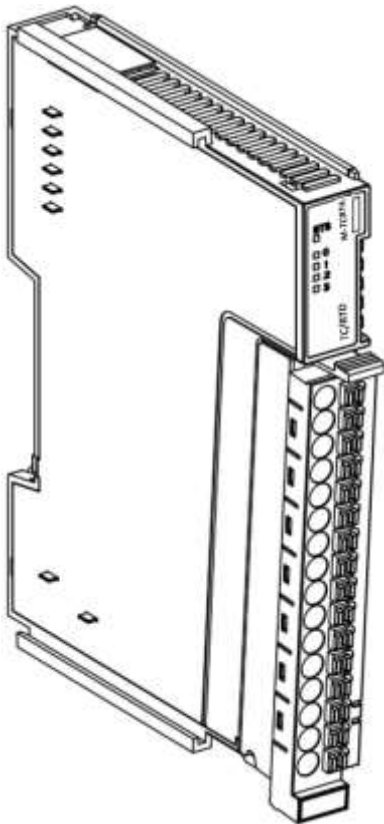

[Module Overview](#)

[Part Names](#)

[Specifications](#)

[LED Indications](#)

[Connection Diagram](#)

[User Configurable Features](#)

[Parameters](#)

[IO Data](#)

Module Overview

M-TCRT4 is 4 channel thermocouple/ RTD input module. Highlighting features are as below.

- Supports inputs like various thermocouple types (J and K) and RTD inputs (PT100, PT1000).
- User configurable signal conditioning for stable analog measurement.
- Easy troubleshooting with module level as well as channel level diagnostics.

These are non-isolated type of input channels.

Part Names

The figure below describes part names of the module.

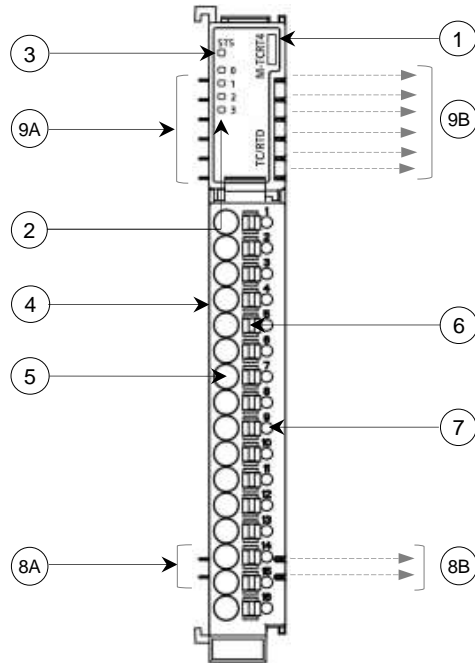

No.	Name	Description
1	M-TCRT4	Module ordering code
2	IO LED Indication	0 to 3: 4, Green colour LEDs for individual input status
3	Module LED Indication	STS: 1, Bi-colour LED for module status
4	Terminal Block	16-point removable push type
5	IO Point	Wire insertion point for IO terminal
6	Push Button	Press to release wire
7	Test Point	To measure signal voltage
8A	Field power supply Interface	2 Incoming pins for field power supply interface
8B		2 Outgoing pins for field power supply interface
9A	System power supply Interface	6 Incoming pins for system power supply interface
9B		6 Outgoing pins for system power supply interface

Specifications

The table below provides technical specifications of **M-TCRT4**.

Specification	Description				
Ordering Code	M-TCRT4				
Number of Input Channels	4 CH., Thermocouple/ RTD, Differential, Non-isolated				
Input Types (user configurable)	RTD	3 Wire PT100 (385): -200°C to 850°C			
		3 Wire PT100 (385): -50°C to +250°C			
	Thermocouple	3 Wire PT1000 (385): -50°C to +250°C			
		J Type: -100 to 1200°C			
Resolution and Overall Accuracy*	K Type: -100 to 1372°C				
	16 bits				
Resolution and Overall Accuracy*	Input Type	Basic Resolution	Basic Digital Output (Integer format)	Overall accuracy in % of FSD	
				25°C	60°C
	PT100	0.1°C	-2000 to 8500	±0.4	±0.8
	PT100	0.01°C	-5000 to 25000	±1.0	±1.2
	PT1000	0.01°C	-5000 to 25000	±1.0	±1.2
	J Type TC	0.035 °C	-1000 to 12000	±1.2	±1.8
	K Type TC	0.049 °C	-1000 to 13720	±1.0	±1.2
ADC Conversion Type	Delta-sigma ($\Delta\Sigma$)				
Absolute Maximum Input	±30 VDC / ±30 mA				
Lead Wire Resistance Compensation	30Ω max. per wire (Applicable for 3-wire PT100, PT1000 input types)				
Cold Junction Compensation	2 sensors on-board (Applicable for thermocouple input)				
	Range	From 0 to 100 °C			
Averaging	Number of averaging samples: 4, 8, 16 (Default), 32 User can configure averaging or digital filter at a time				
Digital Filter	1st order digital filter. User configurable time constant: 10 msec to 5000 msec Default value: 50 ms User can configure averaging or digital filter at a time				

*TC is the abbreviation of the word Thermocouple.

NOTE

Module M-TCRT4 is supported in Modular IO Configurator Tool [V1.9.0.0] onwards.

M-TCRT4 technical specifications are continued...

Specification		Description	
Module Updation Time		Module updation time = Channel 0 conversion time + Channel 1 conversion time + Channel 2 conversion + Channel 3 conversion *	
		The table below provides typical ADC conversion time for supported input types with Filter type setting as “No filter”.	
		Input Type	ADC Conversion time (msec)
		PT100 -200°C to 850°C	50
		PT100 -50°C to 250°C	100
		PT1000 -50°C to 250°C	
TC J Type -100°C to 1200°C	200		
TC K Type -100°C to 1372°C			
Sensor Excitation Current		1 mA for PT100 sensor input 0.25 mA for PT1000 sensor input	
Open Circuit Detection		For PT100 /PT1000 input types, For CJC sensors and thermocouple input types	
Channel Protection		PTC for over current protection of current input up to 70 mA	
Isolation	Input channel to internal circuit	1.5 KV, Optical	
	Input channel to input channel	No isolation	
	Field power supply to input channel	No isolation	
IO Memory Consumption	Input Words (IW)	4 Words	
	Diagnostics (SB) [User configurable]	2 Bytes	
System Power Supply Consumption		100 mA	
Field Power Supply Consumption		47 mA maximum at 24 VDC	
Terminal Block (Removable push type)		16-point	
Recommended Wire Size		0.5 sq. mm to 2.0 sq. mm (AWG 20 to 14), Solid wire or Stranded (flexible) wire with lugs	
Module Dimensions (H x W x D) in mm		105 x 13.2 x 83	

*Channel conversion time (averaging): ADC conversion time X number of averaging samples.
Channel conversion time (digital filter): ADC conversion time + (Time constant X 10).

NOTE

For PT100/ PT1000 input type, open circuit detection is supported for sensor connections. It is not supported for lead wire compensation input at terminal CMPn.

LED Indications

This section provides meaning of LED indications available on module.

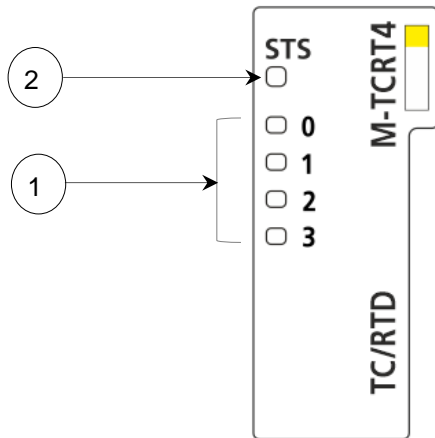

No.	*LED	Colour	Status	Description	
1	0 to 3	Green	ON	Input channel is enabled.	
			Single flash	Following errors may occur on individual input channel. <ul style="list-style-type: none"> - Open circuit [Applicable for thermocouple inputs and PT100/ PT1000 inputs] 	
			Double flash	Invalid configuration and parameterization.	
			OFF	Channel is disabled.	
2	STS	Bi-colour LED	None	Module is powered OFF.	
			Blue Green	ON	Module is powered ON and communicating with Header module.
				Single flash	Communication with Header is not established due to, <ul style="list-style-type: none"> - Module is powered ON and waiting for communication from Header. - Module mismatch.
			Red	ON	One of the following conditions occurred. <ul style="list-style-type: none"> - Factory calibration error - ADC error - Hardware failure is detected on module.
				Single flash	One of the following conditions occurred. <ul style="list-style-type: none"> - No communication from Header - Backplane bus fault detected.
			Yellow	ON	24 VDC field power supply is not available.

*For more details of LED indication states and flashing rates, refer section [Troubleshooting >> LED indications: States and flashing rates](#) in this manual.

Connection Diagram

This section provides wiring details for individual input channel. This module supports input types such as RTD and thermocouple. The figure below shows how to connect field sensors to module. Wiring description is provided on right side wall of the module.

For common wiring recommendations, refer section [Wiring](#). The figures below show various sensors connected to the terminals of module for an example.

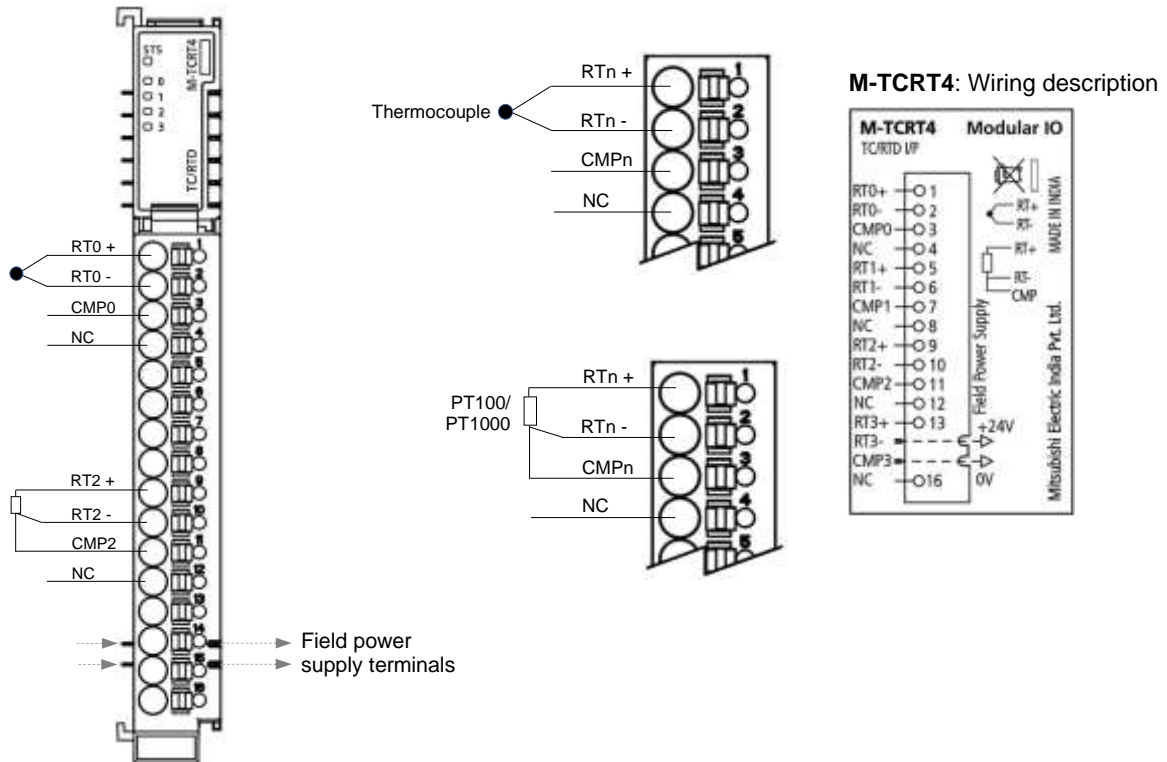

Following are the connection details for individual input type:

- 3-wire PT100/ PT1000 sensor is connected between **RTn+** and **RTn-** along with lead compensation wire connected to **CMPn**.
- Thermocouple input is connected between **RTn+** and **RTn-**.

Here, n is the input channel number 0 to 3.

NOTE

For M-TCRT4, ambient temperature affects the overall accuracy of the module. So, it is recommended to install analog input module away from modules dissipating heat, for example, M-DA2 as far as possible.

NOTE

For PT100/ PT1000 input type, open circuit detection is supported for sensor connections. It is not supported for lead wire compensation input at terminal CMPn.

For thermocouple and PT100/ PT1000 sensors, use cable provided or recommended by sensor manufacturer.

Connect cable shield directly to the good quality earth. It is recommended to keep cable shield at sensor end unconnected.

Use 2-core shielded twisted pair cable for carrying analog signal.

It is recommended to use thermocouple with isolated tip. Accuracy will be hampered, if non isolated type of thermocouple element is used and if it gets connected to improper earth.

User Configurable Features

Module M-TCRT4 provides user configurable features for both input types as shown below,

1. **Digital filter with user defined filter time constant settings.** [Range: 10 msec to 5000 msec].
 - It filters out spurious noise on analog input signal and ensures a stable analog count.
2. **Moving averaging with user definable number of samples.** [Number of samples: 4/ 8/ 16/ 32]
 - This feature is useful when an analog input signal is slowly varying or fluctuating.

User can either apply digital filter or moving average at a time.

3. **Open circuit detection is provided.** This feature is applicable for both thermocouple inputs as well as PT100/ PT1000 inputs.

User can set open circuit value as,

- 7FFFH [Default]
- 0
- Maximum value of range
- Minimum value of range

Refer section [Modular IO Configurator](#) for more details.

Parameters

IO module can be configured in modular IO station using Modular IO Configurator. For addition and removal of IO module, refer section [Modular IO Configurator](#).

User can set following parameters.

Parameter Name	Project Value	Comment
Share diagnostics	Enable [Default]	Enables diagnostic data (SB) sharing with header
	Disable	

Module diagnostic data and channel diagnostic data is available in Status Byte (SB) memory if module parameter “Share diagnostics” is set to Enable.

The table below provides a list of channel parameters that user can set for individual input channel.

Parameter Name	Project Value	Comment
Enable	Yes [Default] No	Enables/ Disables channel
Input Type	PT100: -200 to 850°C [Default] PT100: -50 to 250°C PT1000: -50 to 250°C TC J Type: -100 to 1200°C TC K Type: -100 to 1372°C	Select input type
Filter type	Digital Filter [Default] No Filter Averaging	Select filtering type
Digital filter time constant	50 [Default]	Digital filter time constant (10 to 5000 msec)
Number of averaging samples	4 8 16 [Default] 32	Number of samples for averaging
Open circuit value	7FFFH [Default] 0 Maximum value of range Minimum value of range	Channel data in case of open circuit

IO Data

Following table provides description for Analog input channel data.

Channel	Data Type	Local Address*
CH0	INT	IW n
CH1	INT	IW n+1
CH2	INT	IW n+2
CH3	INT	IW n+3

*Local address (n) value changes as per the slot position of IO module and configuration of modular IO station.

User can monitor the following diagnostics.

Channel	Data Type	Local Address*	Bit Status	Comment
Module Diagnostics	BYTE	SB n	--	--
No field power supply	BOOL	SB n.0	TRUE	24 VDC field power supply is not available.
			FALSE	24 VDC field power supply is available.
ADC fault	BOOL	SB n.1	TRUE	ADC is faulty.
			FALSE	ADC is healthy.
CJC1 error	BOOL	SB n.2	TRUE	On-board CJC1 sensor is faulty.
			FALSE	On-board CJC1 sensor is healthy.
CJC2 error	BOOL	SB n.3	TRUE	On-board CJC2 sensor is faulty.
			FALSE	On-board CJC2 sensor is healthy.
Factory calibration error	BOOL	SB n.4	TRUE	Factory calibration data is invalid.
			FALSE	Factory calibration data is valid.
Reserved	BOOL	SB n.5	Reserved	
⋮	⋮	⋮	⋮	
Reserved	BOOL	SB n.7	Reserved	
CH0 Diagnostics	BYTE	SB n+1	--	--
Channel 0 enabled	BOOL	SB n+1.0	TRUE	If channel0 is enabled
			FALSE	If channel0 is disabled.
Channel 0 open circuit	BOOL	SB n+1.1	TRUE	Sensor is open/ short circuit/ lead wire break
			FALSE	Sensor is connected
Channel 1 enabled	BOOL	SB n+1.2	TRUE	If channel1 is enabled
			FALSE	If channel1 is disabled.
Channel 1 open circuit	BOOL	SB n+1.3	TRUE	Sensor is open/ short circuit/ lead wire break
			FALSE	Sensor is connected

Channel 2 enabled	BOOL	SB n+1.4	TRUE	If channel2 is enabled
			FALSE	If channel2 is disabled.
Channel 2 open circuit	BOOL	SB n+1.5	TRUE	Sensor is open/ short circuit/ lead wire break
			FALSE	Sensor is connected
Channel 3 enabled	BOOL	SB n+1.6	TRUE	If channel3 is enabled
			FALSE	If channel3 is disabled.
Channel 3 open circuit	BOOL	SB n+1.7	TRUE	Sensor is open/ short circuit/ lead wire break
			FALSE	Sensor is connected

For PT100/ PT1000 input type, open circuit is not detected, in case if, lead compensation wire at terminal CMPn gets disconnected.

Module diagnostic data is available in Status Byte (SB) memory if module parameter “Share diagnostics” is set to **Enable**.

Refer section [Troubleshooting](#) for station error code list and error messages.

7.6 M-DA2

[2 CH. Analog Voltage/ Current Output]

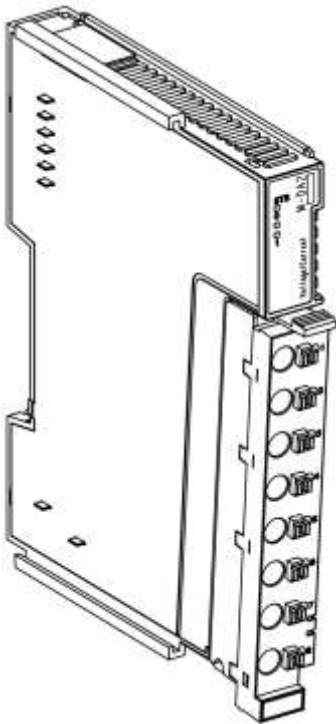

[Module Overview](#)

[Part Names](#)

[Specifications](#)

[LED Indications](#)

[Connection Diagram](#)

[User Configurable Features](#)

[Parameters](#)

[IO Data](#)

Module Overview

M-DA2 is 2 channel analog voltage/ current output module. These output channels are of non-isolated type.

Part Names

The figure below describes part names of the module.

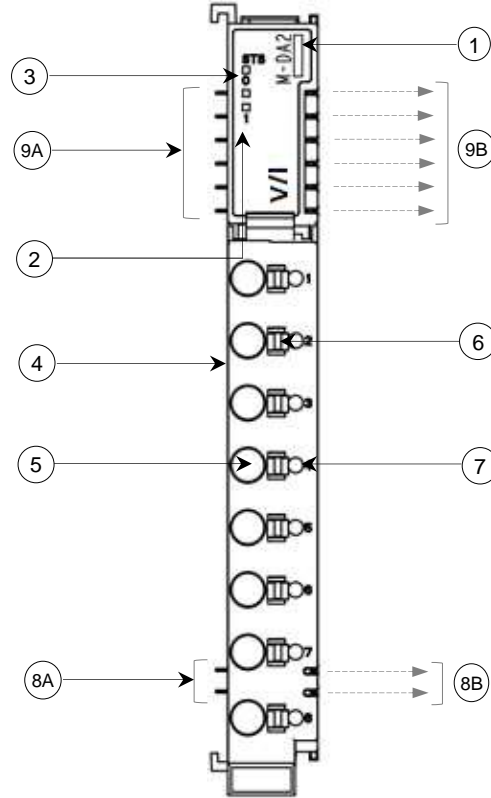

No.	Name	Description
1	M-DA2	Module ordering code
2	IO LED Indication	0 and 1: 2 Green colour LEDs for individual output status
3	Module LED Indication	STS: 1 Bi-colour LED for module status
4	Terminal Block	8-point removable push type
5	IO Point	Wire insertion point for IO terminal.
6	Push Button	Press to release wire
7	Test Point	To measure signal voltage
8A	Field power supply Interface	2 Incoming pins for field power supply interface
8B		2 Outgoing pins for field power supply interface
9A	System power supply Interface	6 Incoming pins for system power supply interface
9B		6 Outgoing pins for system power supply interface

Specifications

The table below provides technical specifications of **M-DA2**.

Specification		Description			
Ordering Code		M-DA2			
Number of Outputs		2 CH., voltage/current, non-isolated, 12-bit resolution			
Output Types		Voltage		Current	
		0 to 10V	-10 to 10V	0 to 20mA	4 to 20mA
Input Data		0 to 4000	-2000 to 2000	0 to 4000	0 to 4000
Resolution		2.5 mV	5 mV	5 μ A	5 μ A
Overall Accuracy (% of FSD)	At 25°C	± 0.1	± 0.1	± 0.2	± 0.2
	At 55°C	± 0.2	± 0.2	± 0.3	± 0.3
Load		> 5 K Ω		0 to 500 Ω	
Module Update Time		2 msec maximum onboard for all channels			
Output Settling Time		2 msec			
IO Memory Consumption		Output Words (QW)	2 Words		
		Diagnostics (SB) [User configurable]	2 Bytes		
Isolation	Field power supply to output channel	No isolation			
	Output channel to output channel	No isolation			
	Output channel to internal circuit	1.5 KV, Optical			
Protections		Short circuit protection for voltage output			
Open Circuit Detection		For current output			
System Power Supply Consumption		95 mA			
Field Power Supply Consumption		132 mA maximum			
Terminal Block (Removable push type)		8-point			
Recommended Wire Size		0.5 sq. mm to 2.0 sq. mm (AWG 20 to 14), Solid wire or Stranded (flexible) wire with lugs			
Module Dimensions (H x W x D) in mm		105 x 13.2 x 83			

LED Indications

This section provides meaning of LED indications available on module.

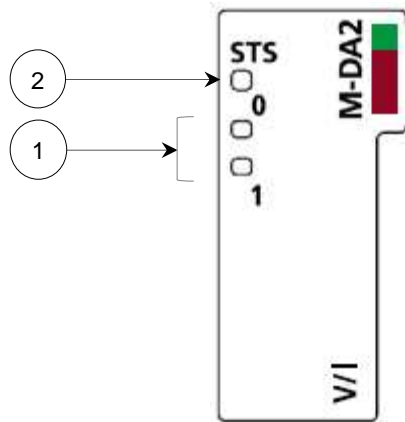

No.	**LED	Colour	Status	Description	
1	0, 1	Green	ON	Channel is enabled.	
			Single flash	Following error may occur for individual output channel. - Open circuit is detected for 0/4 to 20 mA output*	
			Double flash	Invalid configuration and parameterization.	
			OFF	Channel is disabled.	
2	STS	Bi-colour LED	None	Module is powered OFF.	
			Blue Green	ON	Module is powered ON and communicating with Header module.
				Single flash	Communication with Header is not established due to, - Module is powered ON and waiting for communication from Header. - Module mismatch.
			Red	ON	One of the following conditions occurred. - DAC error - Hardware failure is detected on module.
				Single flash	One of the following conditions occurred. - No communication from Header - Backplane bus fault detected.
			Yellow	ON	24 VDC field power supply is not available.

*In case of 0 to 20 mA output, open circuit is detected when non-zero channel data is written.

**For more details of LED indication states and flashing rates, refer section [Troubleshooting >> LED indications: States and flashing rates](#) in this manual.

Connection Diagram

This section provides wiring details for individual output point connected for voltage and current output.

Wiring description is provided on right side wall of the module.

The figure shows module front with 8-point terminal block. Here, Channel0 is connected for voltage output and Channel1 is connected for current output, as an example.

For common wiring recommendations, refer section [Wiring](#).

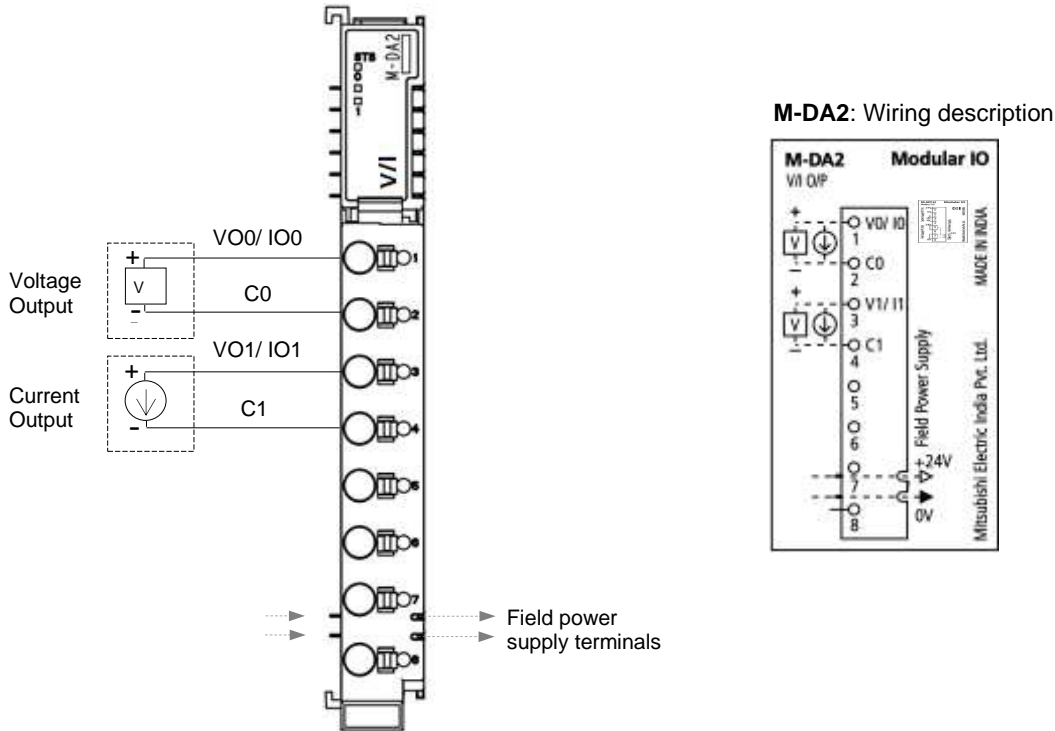

NOTE

It is recommended to use 2-core shielded twisted pair cable for carrying analog signal.

Connect cable shield at module end directly to a good quality earth in panel. It is recommended to keep cable shield at sensor end unconnected.

The Earthing resistance should be 100Ω or less.

NOTE

M-DA2 module has on-board power supply circuit. It dissipates 2.2 W power which causes increase in temperature of the module above 60°C depending upon ambient temperature inside control panel. It is recommended to install M-DA2 module/s in the last slots of a modular IO station.

For modules like analog input module, ambient temperature affects the overall accuracy of the module. So it is recommended to install analog input module away from M-DA2 modules as far as possible.

User Configurable Features

Module M-DA2 provides user configurable Engineering scaling in which channel data is scaled to engineering units defined by minimum and maximum values.

For configuring, user defined engineering scaling, set channel parameter Engineering scaling as **Enable**.

CH(n) Parameters*	Project Value	Comment
Engineering scaling	Enable [Default]	Enables / disables engineering scaling
	Disable	
Minimum Value	0 [Default] [Supported range: -32768 to 32767]	Minimum value for engineering scaling
Maximum Value	100 [Default] [Supported range: -32768 to 32767]	Maximum value for engineering scaling

*Here, n is the channel number.

Parameters

IO module can be configured in modular IO station using Modular IO Configurator. For addition and removal of IO module, refer section [Modular IO Configurator](#).

User can set following parameters.

Parameter Name	Project Value	Comment
Share diagnostics	Enable [Default]	Enables diagnostic data (SB) sharing with header.
	Disable	

Module diagnostic data and channel diagnostic data is available in Status Byte (SB) memory, if module parameter “Share diagnostics” is set to **Enable**.

The table below provides a list of channel parameters that user can set for individual output channel.

Parameter Name	Project Value	Comment
Enable	Yes [Default] No	Enables / disables channel
Output type	Voltage 0 to 10 V [Default] Voltage -10 to 10 V Current 0 to 20 mA Current 4 to 20 mA	Select output type.
Engineering scaling	Disable [Default] Enable	Enables / disables engineering scaling
Minimum value	0 [Default] [Supported range: -32768 to 32767]	Minimum value for engineering scaling
Maximum value	100 [Default] [Supported range: -32768 to 32767]	Maximum value for engineering scaling

IO Data

Following table provides description of Analog output data.

Channel	Data Type	Local Address*
CH0	INT	QW n
CH1	INT	QW n+1

*Local address (n) value changes as per the slot position of IO module and configuration of modular IO station.

NOTE

Output channel generates zero output, in case, if channel data is out of range.

Bitwise significance of diagnostic data of module as well as output channel level, is as below.

Channel	Data Type	Local Address*	Bit Status	Description
Module Diagnostics	BYTE	SB (n)		
No field power Supply	BOOL	SB n.0	TRUE	No 24 VDC Field power supply present on module
			FALSE	24 VDC Field power supply is available on module
DAC Fault	BOOL	SB n.1	TRUE	DAC fault
			FALSE	DAC is working Ok
Reserved	BOOL	SB n.2	Reserved	
Reserved	BOOL	SB n.7	Reserved	
Channel Diagnostics	BYTE	SB n+1		
Channel 0 enabled	BOOL	SB n+1.0	TRUE	CH0 is enabled
			FALSE	CH0 is disabled
Channel 0 open circuit	BOOL	SB n+1.1	TRUE	Open circuit is detected on CH0*
			FALSE	CH0 is working Ok
Channel 1 enabled	BOOL	SB n+1.2	TRUE	CH1 is enabled
			FALSE	CH1 is disabled
Channel 1 open circuit	BOOL	SB n+1.3	TRUE	Open circuit is detected on CH1*
			FALSE	CH1 is working Ok

*Open circuit detection is applicable for current output types. In case of 0 to 20 mA output, open circuit is detected when channel data is other than 0.

Module diagnostic data is available in Status Byte (SB) memory, if module parameter “Share diagnostics” is set to **Enable**.

Refer section [Troubleshooting](#) for station error code list and error messages.

7.7 M-DA4

[4 CH. Analog Voltage/ Current Output]

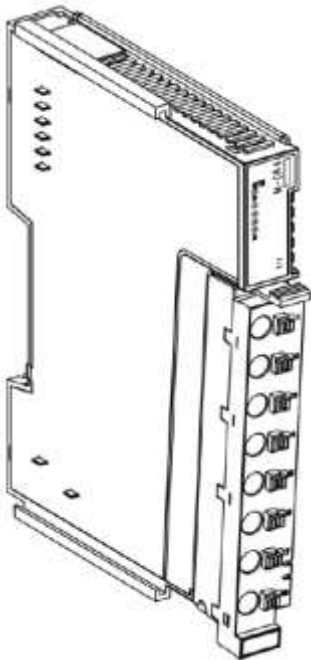

[Module Overview](#)

[Part Names](#)

[Specifications](#)

[LED Indications](#)

[Connection Diagram](#)

[User Configurable Features](#)

[Parameters](#)

[IO Data](#)

Module Overview

M-DA4 is 4 channel analog voltage/ current output module. These output channels are of non-isolated type.

Part Names

The figure below describes part names of the module.

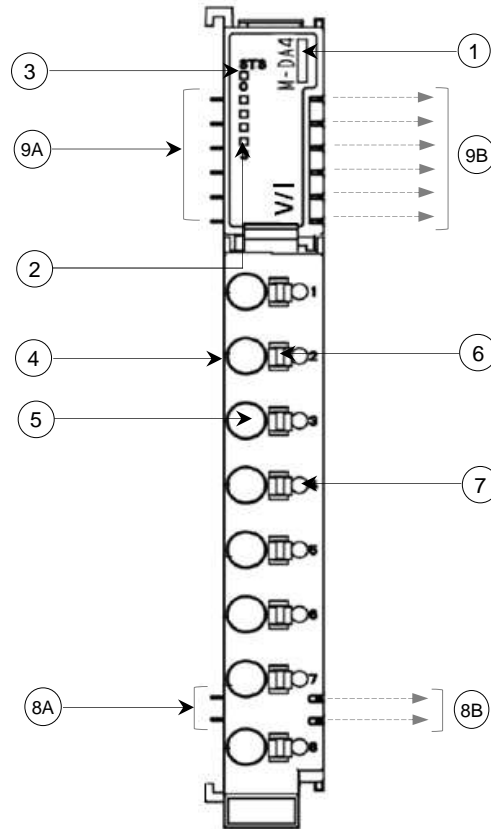

No.	Name	Description
1	M-DA4	Module ordering code
2	IO LED Indication	0 to 3: 4 Green colour LEDs for individual output status
3	Module LED Indication	STS: 1 Bi-colour LED for module status
4	Terminal Block	8-point removable, push type
5	IO Point	Wire insertion point for IO terminal.
6	Push Button	Press to release wire
7	Test Point	To measure signal voltage
8A	Field power supply Interface	2 Incoming pins for field power supply interface
8B		2 Outgoing pins for field power supply interface
9A	System power supply Interface	6 Incoming pins for system power supply interface
9B		6 Outgoing pins for system power supply interface

Specifications

The table below provides technical specifications of **M-DA4**.

Specification		Description			
Ordering Code		M-DA4			
Number of Outputs		4 CH., voltage/current, non-isolated, 16-bit resolution			
Output Types		Voltage		Current	
		0 to 10V	-10 to 10V	0 to 20mA	4 to 20mA
Input Data		0 to 32000	-32000 to 32000	0 to 32000	0 to 32000
Resolution		0.3 mV	0.3 mV	0.6 μ A	0.6 μ A
Overall Accuracy (% of FSD)	At 25°C	\pm 0.18	\pm 0.18	\pm 0.2	\pm 0.2
	At 55°C	\pm 0.2	\pm 0.2	\pm 0.25	\pm 0.25
Load		> 5 K Ω		0 to 500 Ω	
Module Updation Time		2 msec maximum onboard for all channels			
Output Settling Time		6 msec			
IO Memory Consumption		Output Words (QW)	4 Words		
		Diagnostics (SB) [User configurable]	2 Bytes		
Isolation	Field power supply to output channel	No isolation			
	Output channel to output channel	No isolation			
	Output channel to internal circuit	1.5 KV, Optical			
Protections		Short circuit protection for voltage output			
Open Circuit Detection		For current output			
System Power Supply Consumption		105 mA			
Field Power Supply Consumption		190 mA maximum			
Terminal Block (Removable push type)		8-point			
Recommended Wire Size		0.5 sq. mm to 2.0 sq. mm (AWG 20 to 14), Solid wire or Stranded (flexible) wire with lugs			
Module Dimensions (H x W x D) in mm		105 x 13.2 x 83			

LED Indications

This section provides meaning of LED indications available on module.

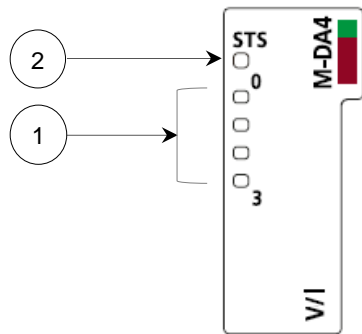

No.	**LED	Colour	Status	Description	
1	0 to 3	Green	ON	Channel is enabled.	
			Single flash	Following error may occur for individual output channel. - Open circuit is detected for 0/4 to 20 mA output*	
			Double flash	Invalid configuration and parameterization.	
			OFF	Channel is disabled.	
2	STS	Bi-colour LED	None	Module is powered OFF.	
			Blue Green	ON	Module is powered ON and communicating with Header module.
				Single flash	Communication with Header is not established due to, - Module is powered ON and waiting for communication from Header. - Module mismatch.
			Red	ON	One of the following conditions occurred. - DAC error - Hardware failure is detected on module.
				Single flash	One of the following conditions occurred. - No communication from Header - Backplane bus fault detected.
Yellow	ON	24 VDC field power supply is not available.			

*In case of 0 to 20 mA output, open circuit is detected when non-zero channel data is written.

**For more details of LED indication states and flashing rates, refer section [Troubleshooting >> LED indications: States and flashing rates](#) in this manual.

Connection Diagram

This section provides wiring details for individual output point connected for voltage and current output.

Wiring description is provided on right side wall of the module.

The figure shows module front with 8 points terminal block. Voltage and current output is provided at same output terminals depending on configuration. Here, Channel0, Channel2 are connected for voltage output and Channel1, Channel3 are connected for current output, as an example.

For common wiring recommendations, refer section [Wiring](#).

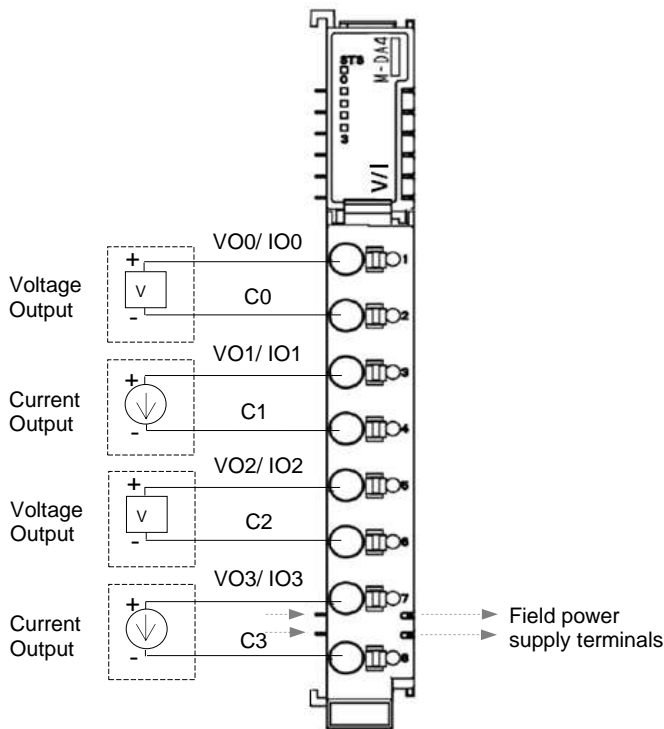

M-DA4: Wiring description

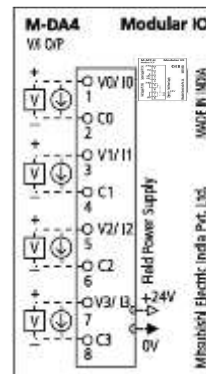

NOTE

It is recommended to use 2-core shielded twisted pair cable for carrying analog signal.

Connect cable shield at module end directly to a good quality earth in panel. It is recommended to keep cable shield at sensor end unconnected.

The Earthing resistance should be 100Ω or less.

User Configurable Features

Module M-DA4 provides user configurable Engineering scaling in which channel data is scaled to engineering units defined by minimum and maximum values.

For configuring, user defined engineering scaling, set channel parameter Engineering scaling as **Enable**.

CH(n) Parameters*	Project Value	Comment
Engineering scaling	Enable [Default]	Enables / disables engineering scaling
	Disable	
Minimum Value	0 [Default] [Supported range: -32768 to 32767]	Minimum value for engineering scaling
Maximum Value	100 [Default] [Supported range: -32768 to 32767]	Maximum value for engineering scaling

*Here, n is the channel number.

Parameters

IO module can be configured in modular IO station using Modular IO Configurator. For addition and removal of IO module, refer section [Modular IO Configurator](#).

User can set following parameters.

Parameter Name	Project Value	Comment
Share diagnostics	Enable [Default]	Enables diagnostic data (SB) sharing with header.
	Disable	

Module diagnostic data and channel diagnostic data is available in Status Byte (SB) memory if module parameter “Share diagnostics” is set to **Enable**.

The table below provides a list of channel parameters that user can set for individual output channel.

Parameter Name	Project Value	Comment
CH0 Parameters		
Enable	Yes [Default] No	Enables / disables channel
Output type	Voltage 0 to 10 V [Default] Voltage -10 to +10 V Current 0 to 20 mA Current 4 to 20 mA	Select output type.
Engineering scaling	Disable [Default] Enable	Enables / disables engineering scaling
Minimum value	0 [Default] [Supported range: -32768 to 32767]	Minimum value for engineering scaling
Maximum value	100 [Default] [Supported range: -32768 to 32767]	Maximum value for engineering scaling

IO Data

Following table provides description of Analog output data.

Channel	Data Type	Local Address*
CH0	INT	QW n
CH1	INT	QW n+1
CH2	INT	QW n+2
CH3	INT	QW n+3

*Local address (n) value changes as per the slot position of IO module and configuration of modular IO station.

NOTE

Output channel generates maximum output, in case, if invalid channel data is written.

Bitwise significance of diagnostic data of module level, is as below.

Channel	Data Type	Local Address*	Bit Status	Description
Module Diagnostics	BYTE	SB (n)		
No field power Supply	BOOL	SB n.0	TRUE	No 24 VDC Field power supply present on module
			FALSE	24 VDC Field power supply is available on module
DAC Fault	BOOL	SB n.1	TRUE	DAC fault
			FALSE	DAC is working Ok
Reserved	BOOL	SB n.2	Reserved	
Reserved	BOOL	SB n.7	Reserved	

Module diagnostic data is available in Status Byte (SB) memory if module parameter “Share diagnostics” is set to Enable.

Refer section [Troubleshooting](#) for station error code list and error messages.

Bitwise significance of diagnostic data of output channel, is as below.

Channel	Data Type	Local Address*	Bit Status	Description
Channel Diagnostics	BYTE	SB n+1		
Channel 0 enabled	BOOL	SB n+1.0	TRUE	CH0 is enabled
			FALSE	CH0 is disabled
Channel 0 open circuit	BOOL	SB n+1.1	TRUE	Open circuit is detected on CH0*
			FALSE	CH0 is working Ok
Channel 1 enabled	BOOL	SB n+1.2	TRUE	CH1 is enabled
			FALSE	CH1 is disabled
Channel 1 open circuit	BOOL	SB n+1.3	TRUE	Open circuit is detected on CH1*
			FALSE	CH1 is working Ok
Channel 2 enabled	BOOL	SB n+1.4	TRUE	CH2 is enabled
			FALSE	CH2 is disabled
Channel 2 open circuit	BOOL	SB n+1.5	TRUE	Open circuit is detected on CH2*
			FALSE	CH2 is working Ok
Channel 3 enabled	BOOL	SB n+1.6	TRUE	CH3 is enabled
			FALSE	CH3 is disabled
Channel 3 open circuit	BOOL	SB n+1.7	TRUE	Open circuit is detected on CH3*
			FALSE	CH3 is working Ok

*Open circuit detection is applicable for current output types. In case of 0 to 20 mA output, open circuit is detected when channel data is other than 0.

[Back To Index Page](#)

8 System Modules

System Modules: Overview	
System Power Extension Module	M-SPE
Field Power Distribution Module	M-FPD
Field Power Isolator Module	M-FPI
Shield Termination Module	M-ST
Bus End Module	M-BE
2-Slots, 3-Slots and 5-Slots Base Modules	M-B2, M-B3, M-B5
Redundant AC Power Supply, 3.5A, Module	M-APSU
24 VDC Power Supply, 3A Module	M-DPSU
IO Adapter Module	M-ADP
Blank Cover Module	M-BC









Overview

System modules are auxiliary modules in modular IO station, which are added to fulfil specific purpose like providing additional system power source and providing terminals to connect sensors and actuators, etc.

NOTE

System modules are passive modules and not intelligent modules like IO modules. These modules do not consume any IO slot and IO points. So Header module does not provide any information about system modules.

Following types of system modules are available.

Ordering Information	Ordering Code	Colour Identification*
System Power Extension Module	M-SPE	
Field Power Isolator Module	M-FPI	
Shield Termination Module	M-ST	
Field Power Distribution Module	M-FPD	
Bus End Module	M-BE	--
3-Slots, 5-Slots Base Modules	M-B3, M-B5	--
Redundant AC Power Supply, 3.5A Module	M-APSU	
24 VDC Input Power Supply	M-DPSU	
Redundant Header Adapter Module	M-ADP	
Blank Cover Module	M-BC	

*Color code is provided on LED label and at bottom side of terminal block. Users should always ensure that color code of LED label and terminal block is identical.

NOTE

IO modules with 24 VDC Field power supply only are available as on May 2018.

Subsequent sections explain purpose of individual system module in modular IO station.

8.1 M-SPE

[System Power Extension Module]

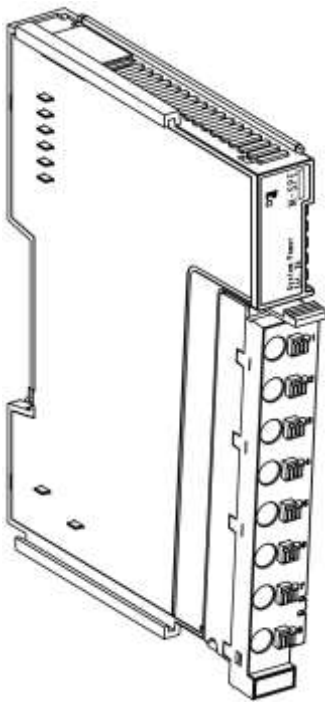

[Module Overview](#)

[Part Names](#)

[Specifications](#)

[LED Indications](#)

[Connection Diagram](#)

Module Overview

In a modular IO station, Header module provides system power supply for IO modules. This supply is connected to IO modules through pins and receptacles interface of each module. If number of IO modules attached to Header module increases, system power consumption increases and then the system power supply provided by Header module will not be sufficient. In such case, user needs to add system power supply extension module in the station.

NOTE

Modular IO Configurator keeps module of system power consumption and warns user to add system power extension module M-SPE whenever required.

Part Names

The figure below describes part names of the module.

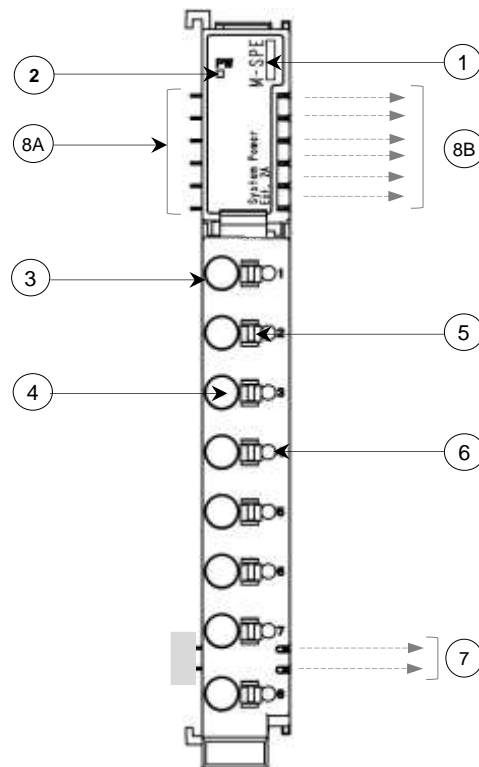

NOTE

Module M-SPE also provides field power isolation similar to module M-FPI.

No.	Name	Description
1	M-SPE	Module ordering code
2	Module LED Indication	PW: 1, Green LED for module power status
3	Terminal Block	8-point removable push type
4	IO Point	Wire insertion point for IO terminals
5	Push Button	Press to release wire
6	Test Point	To measure signal voltage
7	Field Power Supply Interface	2, Outgoing pins for field power supply interface
8A	System Power Supply Interface	6, Incoming pins for system power supply interface
8B		6, Outgoing pins for system power supply interface

Specifications

The table below provides technical specifications of **M-SPE**.

Specification		Description
Module Ordering Code		M-SPE
System Power Supply	Input voltage	24 VDC (11 to 28.8 VDC, ripple included), 12 Watt
	Inrush current	20 A for 20 µsec duration
	Output voltage	5 VDC
	Output current for IO modules	2 A
	Protection	Reverse polarity protection
	Isolation	Non-isolated
Field Power Supply	Voltage	24 VDC (18 to 30 VDC, ripple included)
	Maximum input current at 24 VDC	5 A per input terminal
	Current	10 A
Terminal block (Removable push type)		8-point
Recommended Wire Size		0.5 sq. mm to 2.0 sq. mm (AWG 20 to 14), Solid wire or Stranded (flexible) wire with lugs
Module Dimensions (H x W x D) in mm		105 x 13.2 x 83

LED Indications

This section provides meanings of LED indications available on module.

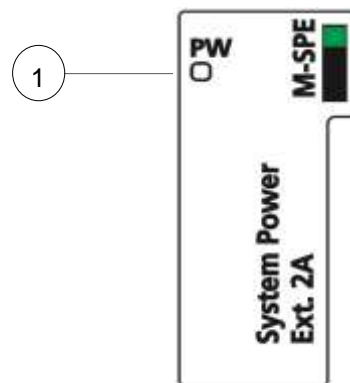

No.	LED	Colour	Status	Description
1	PW	Green	OFF	Module is powered OFF.
			ON	Module is powered ON.

Connection Diagram

The figure shows module M-SPE front with 8-point terminal block. Wiring description is provided on right side wall of the module.

For common wiring recommendations, refer section [Wiring](#).

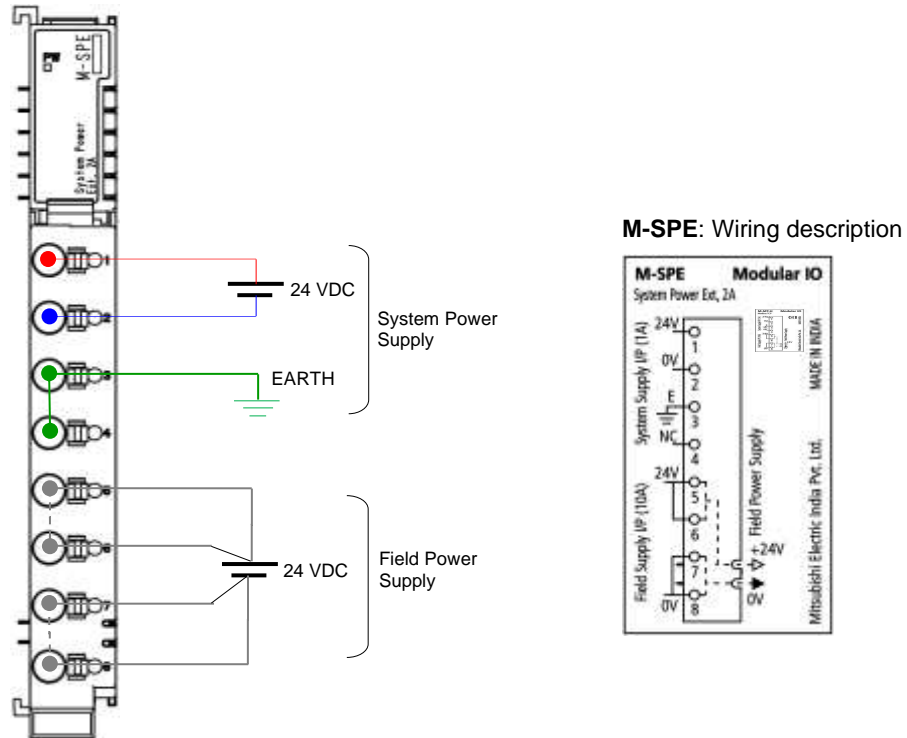

Connect system power supply between first two terminals (i.e. terminal 1 and 2).

Connect terminals 3/ 4 to clean EARTH directly.

Connect +24 VDC field power supply to terminal numbers 5 and 6.

Connect field power supply ground to terminal numbers 7 and 8.

NOTE

Current carrying capacity of each terminal of terminal block is 5 A max. Field power supply interface between modules has current carrying capacity of 10 A.

So it is necessary to connect 2 wires from source of field power supply to utilize maximum capacity of 10 A.

Field power supply connected to terminal block is directly carried to field power supply pins for interfacing with IO modules.

Ensure that EARTH cable is thick and short as far as possible to provide low impedance path.

NOTE

Module M-SPE also acts as field power supply isolation similar to module M-FPI. So it is necessary to connect field power supply to the module.

The figure below shows system power supply connections and field power supply connections in a modular IO station when M-SPE is used.

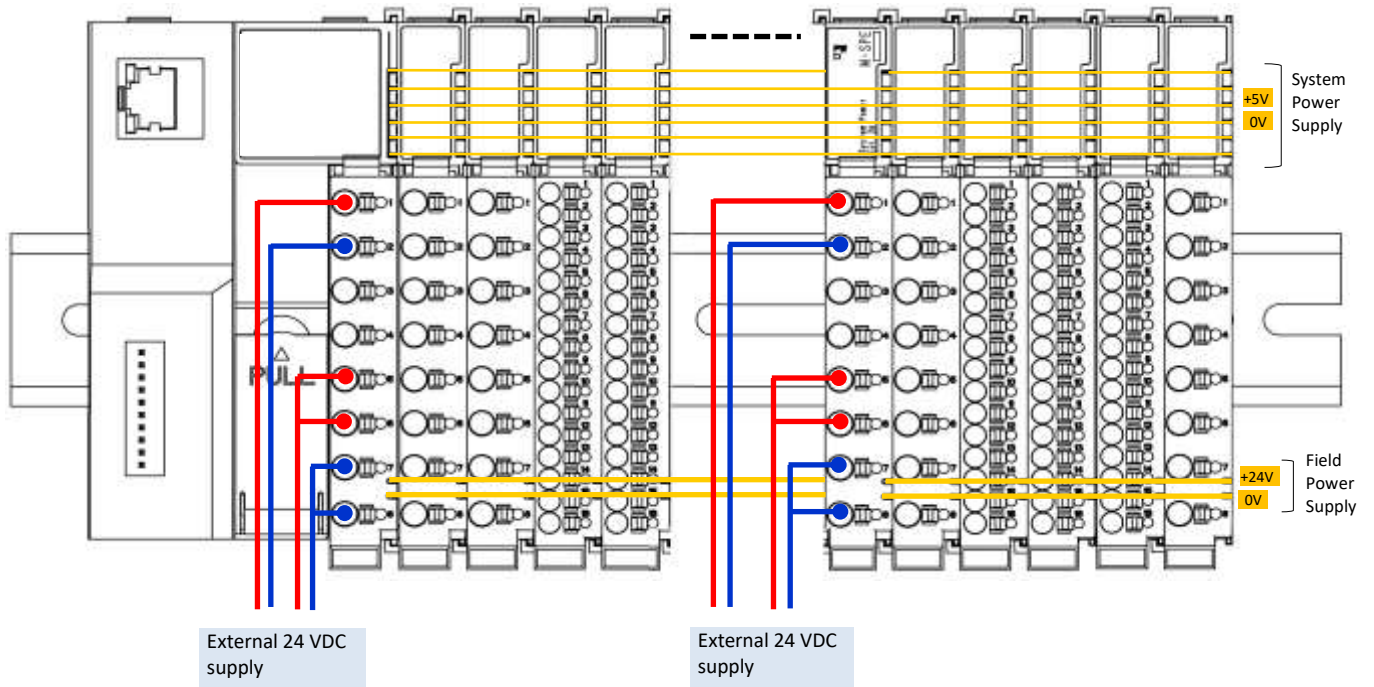

8.2 M-FPD

[Field Power Distribution Module]

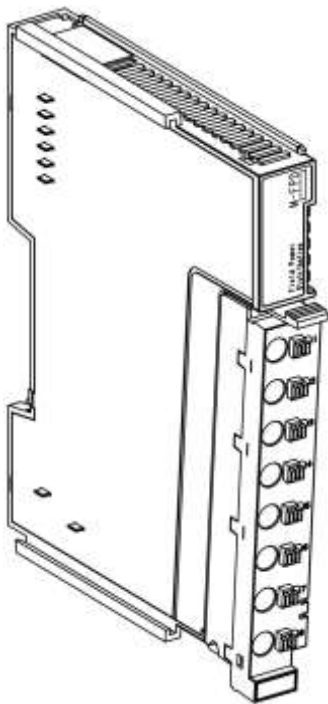

[Module Overview](#)

[Part Names](#)

[Specifications](#)

[Connection Diagram](#)

Module Overview

In a modular IO station, field power distribution module M-FPD provides additional terminals for the field power supply. Module M-FPD provides 8 terminals out of which 4 terminals provide 24 VDC and 4 terminals provide 0 VDC connections. It avoids use of extra terminals in the control panel and facilitates ease of sensor and actuator connections.

Module M-FPD can be attached in following cases

- Case 1:** User can connect field power supply from module M-FPD to a sensor and connect sensor output to analog input module like M-UAD2.
- Case 2:** User can connect actuators between terminal of output module e.g. M-4DE and 0 VDC terminals of M-FPD.

Part Names

Below figure describes part names of the module.

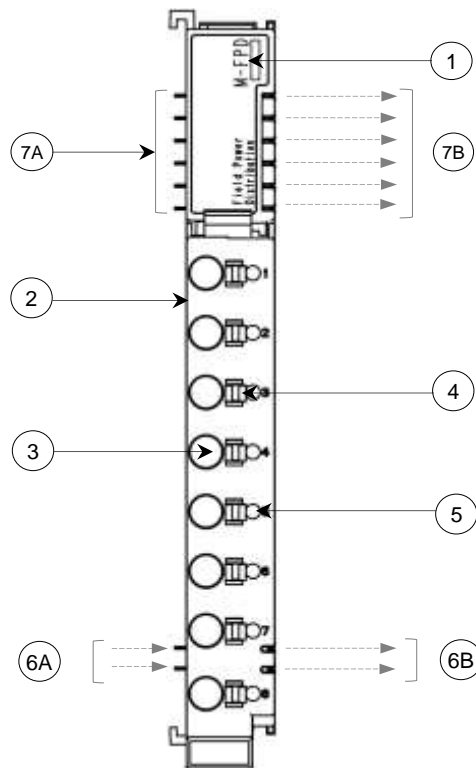

No.	Name	Description
1	M-FPD	Module ordering code
2	Terminal Block	8-point removable push type
3	IO Point	Wire insertion point for IO terminals
4	Push Button	Press to release wire
5	Test Point	To measure signal voltage
6A	Field Power Supply Interface	2, Incoming pins for field power supply interface
6B		2, Outgoing pins for field power supply interface
7A	System Power Supply Interface	6, Incoming pins for system power supply interface
7B		6, Outgoing pins for system power supply interface

Specifications

The table below provides technical specifications of **M-FPD**.

Specification	Description
Module Ordering Code	M-FPD
Field Voltage	24 VDC, 0 VDC
Field power contact Current	Max. 10 Amps.
Terminal block (Removable push type)	8-point
Recommended Wire Size	0.5 sq. mm to 2.0 sq. mm (AWG 20 to 14), Solid wire or Stranded (flexible) wire with lugs
Module Dimensions (H x W x D) in mm	105 x 13.2 x 83

Connection Diagram

The figure shows module (M-FPD) front with 8-point terminal block. Wiring description is provided on right side wall of the module.

For common wiring recommendations, refer section [Wiring](#).

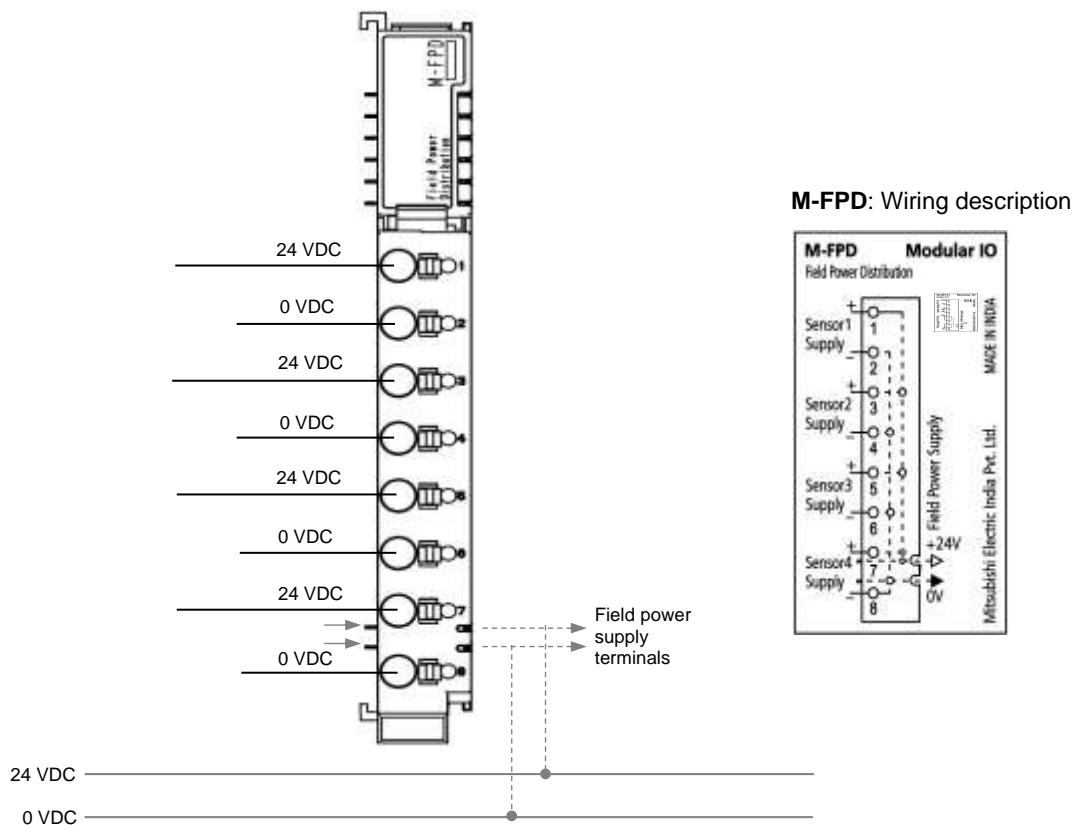

NOTE

User should note that field power supply received at 2 incoming pins is connected to the terminals of module M-FPD internally and the capacity of pins and receptacles interface of modules is 10 A maximum. So user should consider field power supply consumption while using module M-FPD. When field power supply consumption of IO modules exceeds 10 A, use module M-FPI as explained in section [8.3 M-FPI](#).

User can connect field power supply from module M-FPD to a sensor and connect sensor output to analog input and output modules like M-UAD2, M-DA2.

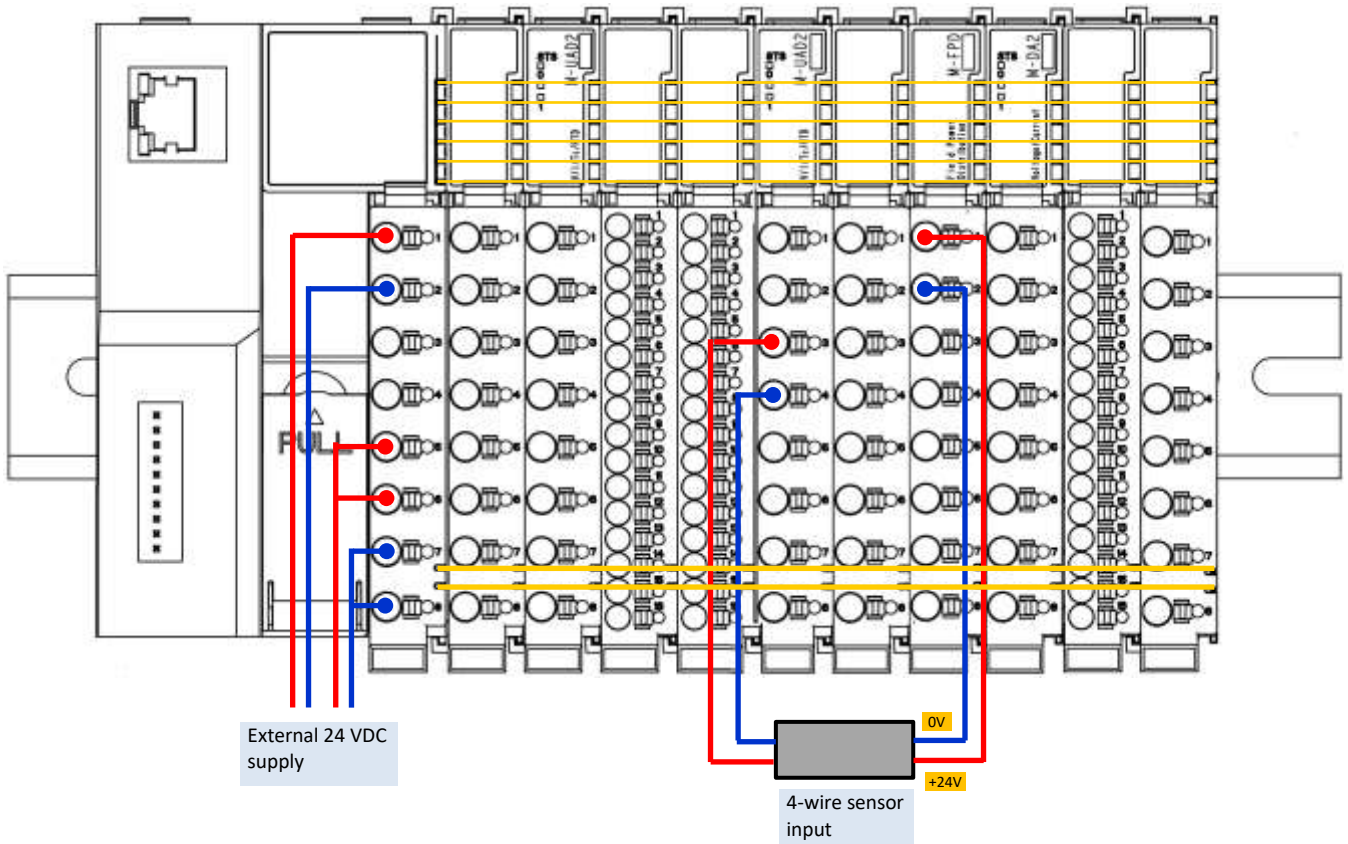

8.3 M-FPI

[Field Power Isolator Module]

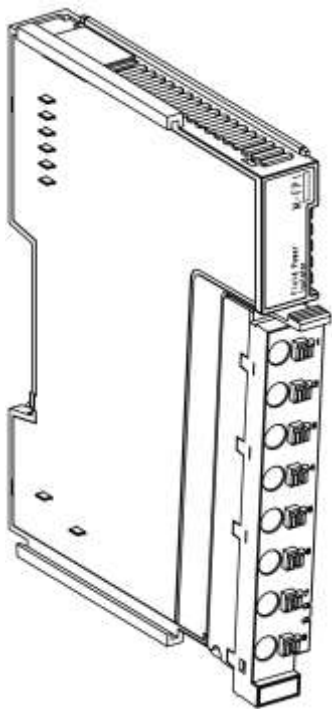

[Module Overview](#)

[Part Names](#)

[Specifications](#)

[Connection Diagram](#)

Module Overview

In a modular IO station, field power supply is connected to a Header module. This supply is connected to IO modules through pins and receptacles interface of each module. Capacity of pins and receptacles interface of modules is 10A maximum.

It is necessary to add M-FPI module in a station in following conditions.

- Case 1:** Each module consumes field power supply depending upon number of inputs, outputs turned ON at a time. For field power supply consumption, refer specification section of individual module when total field power supply consumption by number of IO modules attached exceeds 10 A, user should add M-FPI module.
- Case 2:** In some applications, there is need to use different power supply sources for inputs and outputs. In such case, user should attach input modules starting from slot 1 and utilize field power supply connected to a Header module. Then user should add M-FPI module with field power supply from different source and attach output modules afterwards.
- Case 3:** If a station is attached with IO modules operating with different field voltage levels such as 24 VDC, 12 VDC, 48 VDC, etc. User should attach M-FPI module with different field power supply connection and then attach IO module with different field voltage level.

Part Names

Below figure describes part names of the module.

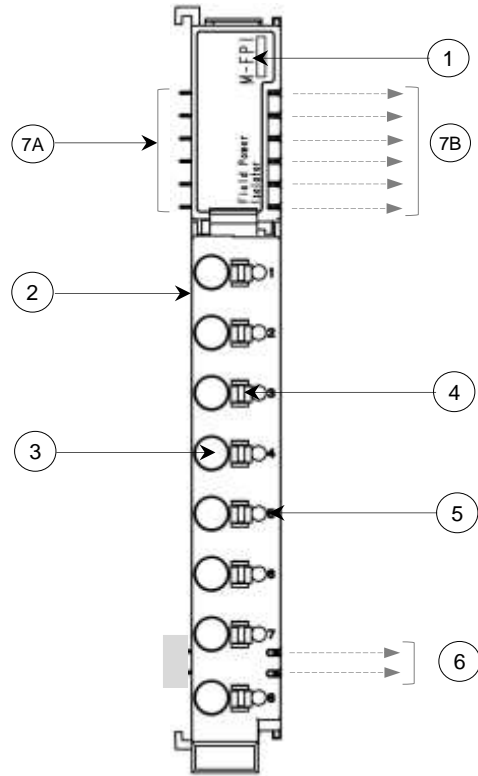

No.	Name	Description
1	M-FPI	Module ordering code
2	Terminal Block	8-point removable push type
3	IO Point	Wire insertion point for terminals
4	Push Button	Press to release wire
5	Test Point	To measure signal voltage
6	Field Power Supply Interface	2, Outgoing pins for field power supply interface
7A	System Power Supply Interface	6, Incoming pins for system power supply interface
7B		6, Outgoing pins for system power supply interface

Specifications

The table below provides technical specifications of **M-FPI**.

Specification	Description
Module ordering code	M-FPI
Field voltage	5 VDC/ 12 VDC/ 24 VDC/ 48 VDC/ 110 VAC/ 220 VAC
Field power contact current	5 A per input terminal
Terminal block (Removable push type)	8-point
Recommended Wire Size	0.5 sq. mm to 2.0 sq. mm (AWG 20 to 14), Solid wire or Stranded (flexible) wire with lugs
Module Dimensions (H x W x D) in mm	105 x 13.2 x 83

NOTE

IO modules with 24 VDC Field power supply only are available as on May 2018.

Connection Diagram

The figure shows module M-FPI front with 8-point terminal block. Wiring description is provided on right side wall of the module.

For common wiring recommendations, refer section [Wiring](#).

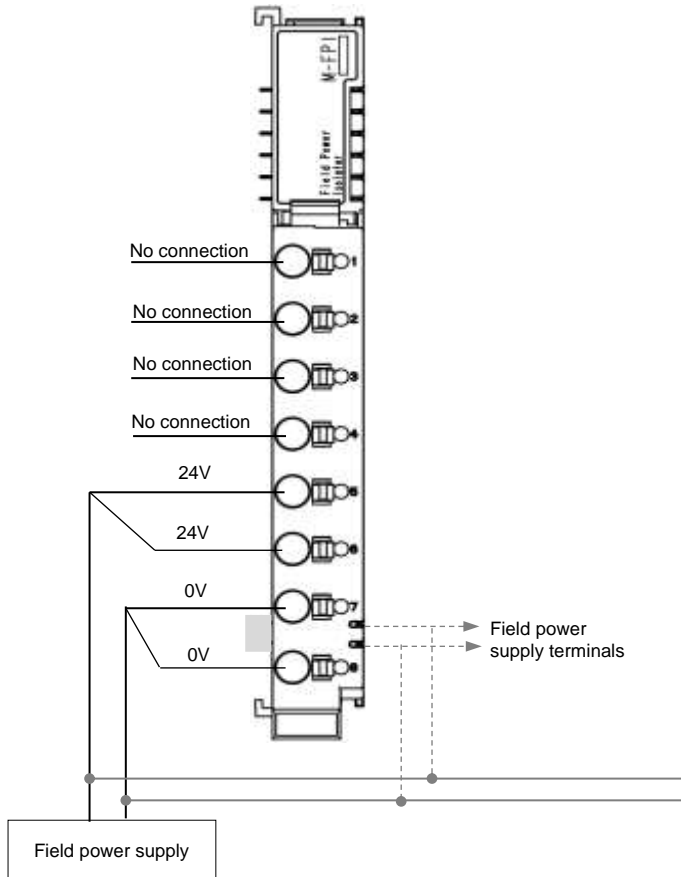

M-FPI: Wiring description

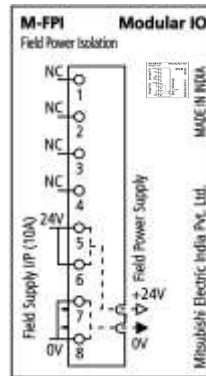

NOTE

Current carrying capacity of each terminal of terminal block is 5 A max. Field power supply interface between modules has current carrying capacity of 10 A.

So it is necessary to connect 2 wires from source of field power supply to utilize maximum capacity of 10 A.

Field power supply connected to terminal block is directly carried to field power supply pins for interfacing with IO modules.

NOTE

IO modules attached on the right side of module M-FPI, utilize field power supply connected to module M-FPI.

Case 1: Each module consumes field power supply depending upon number of inputs, outputs turned ON at a time. When total field power supply consumption by number of IO modules attached exceeds 10 A, user should add M-FPI module.

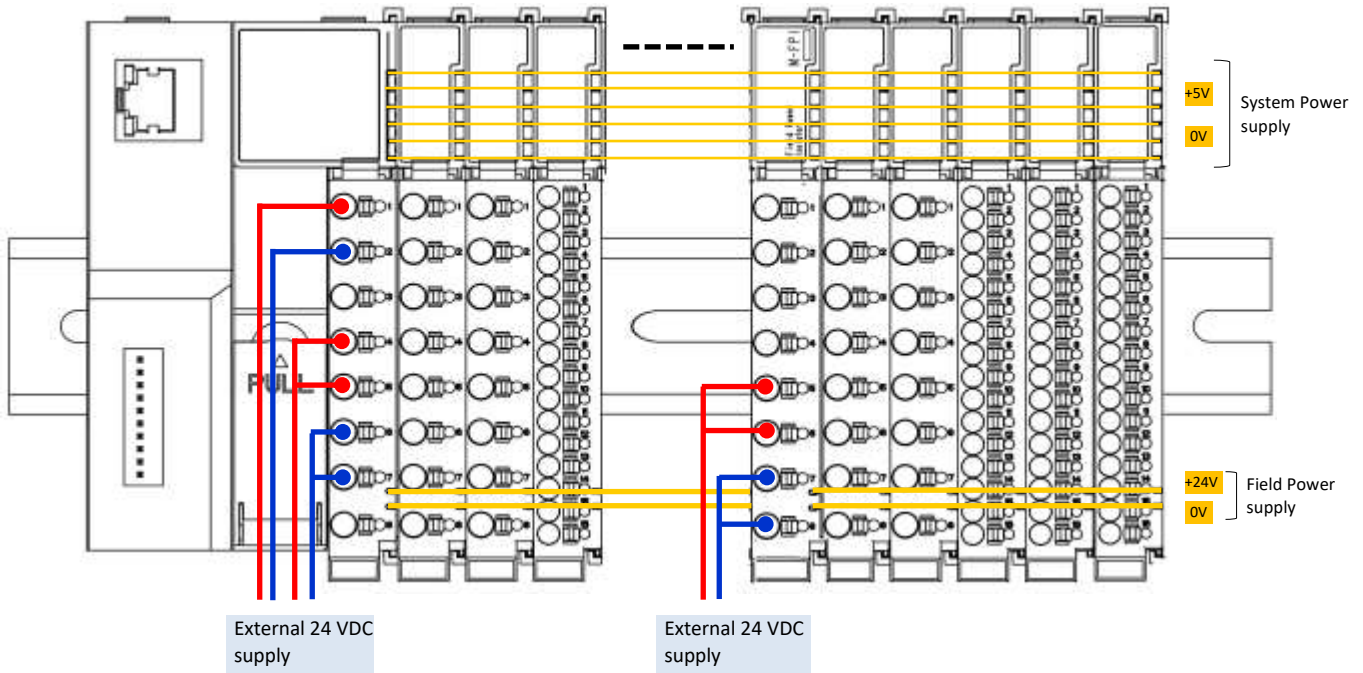

Case 2: In some applications, there is need to use different power supply sources for inputs and outputs. In such case, user should attach input modules starting from slot 1 and utilize field power supply connected to a Header module. Then user should add M-FPI module with field power supply from different source and attach output modules afterwards.

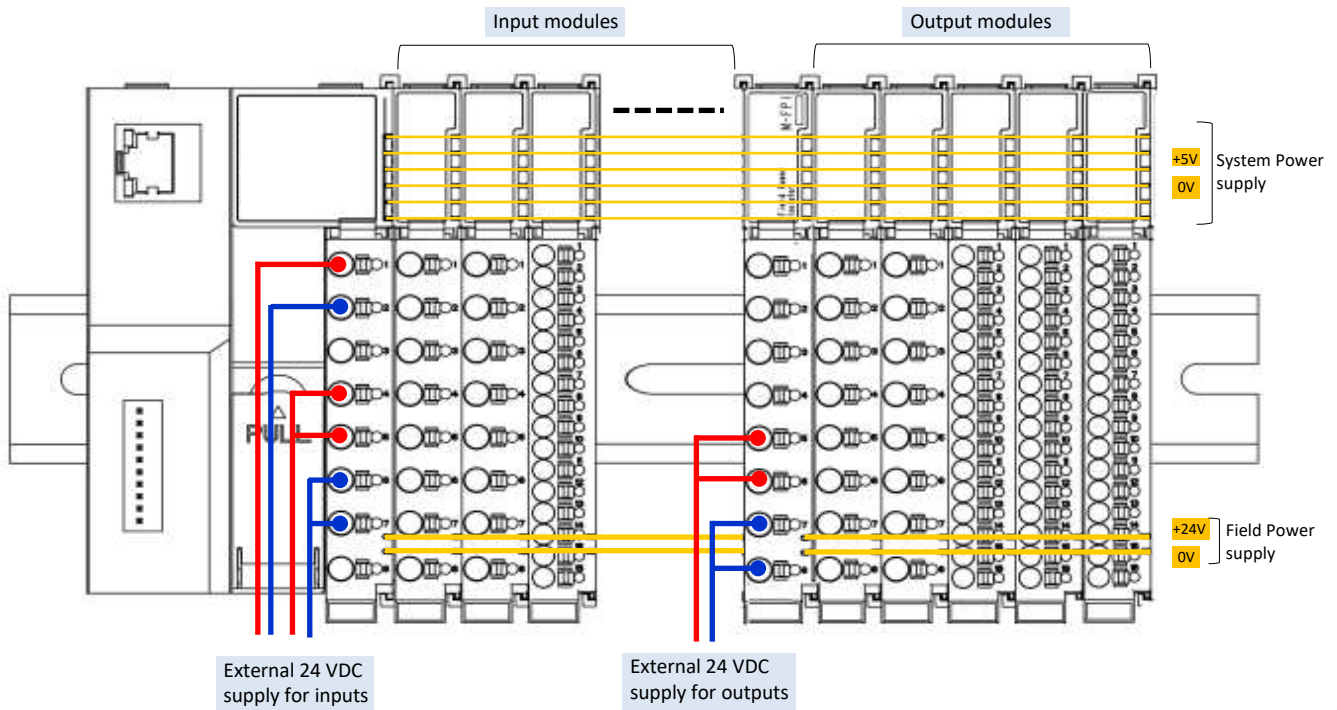

Case 3: If a station is attached with IO modules operating with different field voltage levels such as 24 VDC, 12 VDC, 48 VDC, etc. User should attach M-FPI module with different field power supply connection and then attach IO module with different field voltage level.

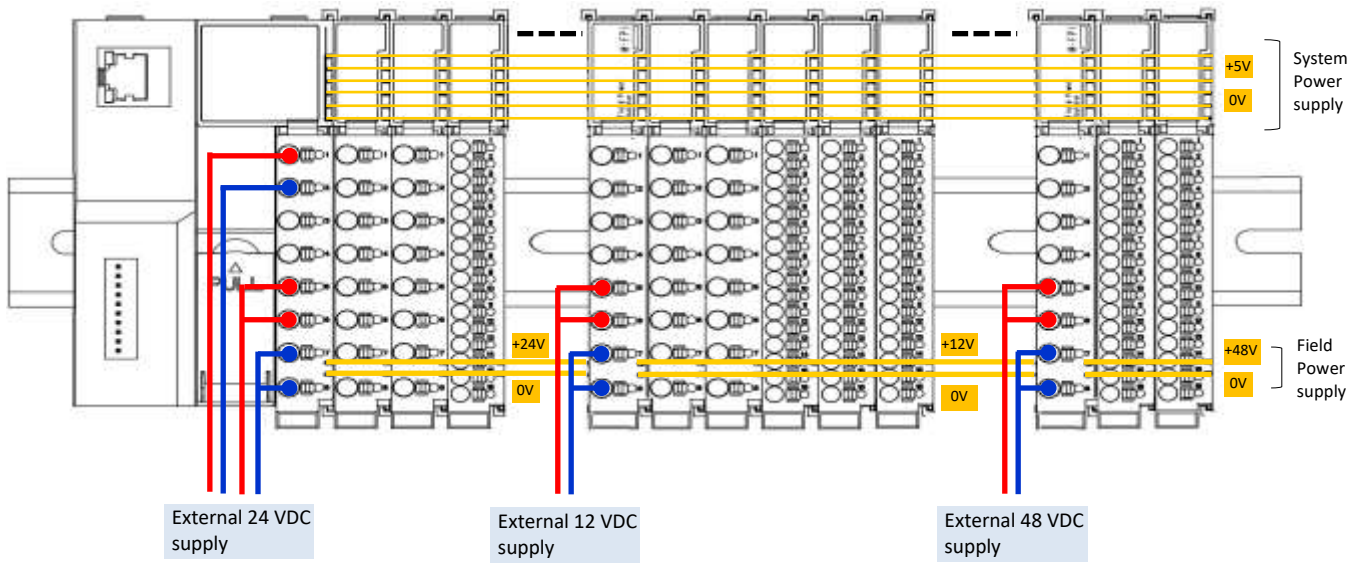

NOTE

IO modules with 24 VDC Field power supply only are available as on May 2018.

8.4 M-ST

[Shield Termination Module]

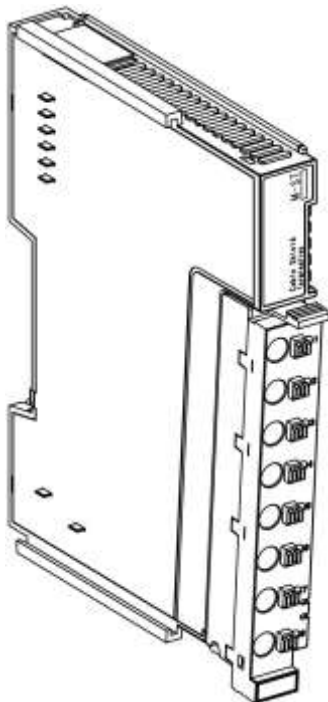

[Module Overview](#)

[Part Names](#)

[Specifications](#)

[Connection Diagram](#)

Module Overview

In a modular IO station, shield termination module M-ST provides terminals to connect shield of cables carrying low level signals like analog, communication, etc. So, it is recommended to attach module M-ST after IO module which provides such interfaces e.g. M-UAD2, M-DA2 where analog IOs are connected.

Part Names

Below figure describes part names of the module.

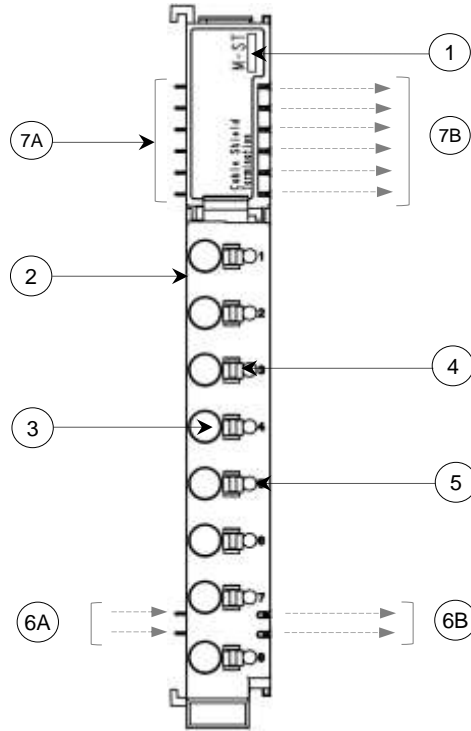

No.	Name	Description
1	M-ST	Module ordering code
2	Terminal Block	8-point removable push type
3	IO Point	Wire insertion point for IO terminals
4	Push Button	Press to release wire
5	Test Point	To measure signal voltage
6A	Field Power Supply Interface	2, Incoming pins for field power supply interface
6B		2, Outgoing pins for field power supply interface
7A	System Power Supply Interface	6, Incoming pins for system power supply interface
7B		6, Outgoing pins for system power supply interface

Specifications

The table below provides technical specifications of **M-ST**.

Specification	Description
Module ordering code	M-ST
Number of shield terminals	8
Contact current at terminal	5 A per input terminal
Terminal Block (Removable push type)	8-point
Recommended Wire Size	0.5 sq. mm to 2.0 sq. mm (AWG 20 to 14), Solid wire or Stranded (flexible) wire with lugs
Dimensions (in mm)	105 x 13.2 x 83

Connection Diagram

The figure shows module M-ST front with 8 point terminal block. Wiring description is provided on right side wall of the module.

For common wiring recommendations, refer section [Wiring](#).

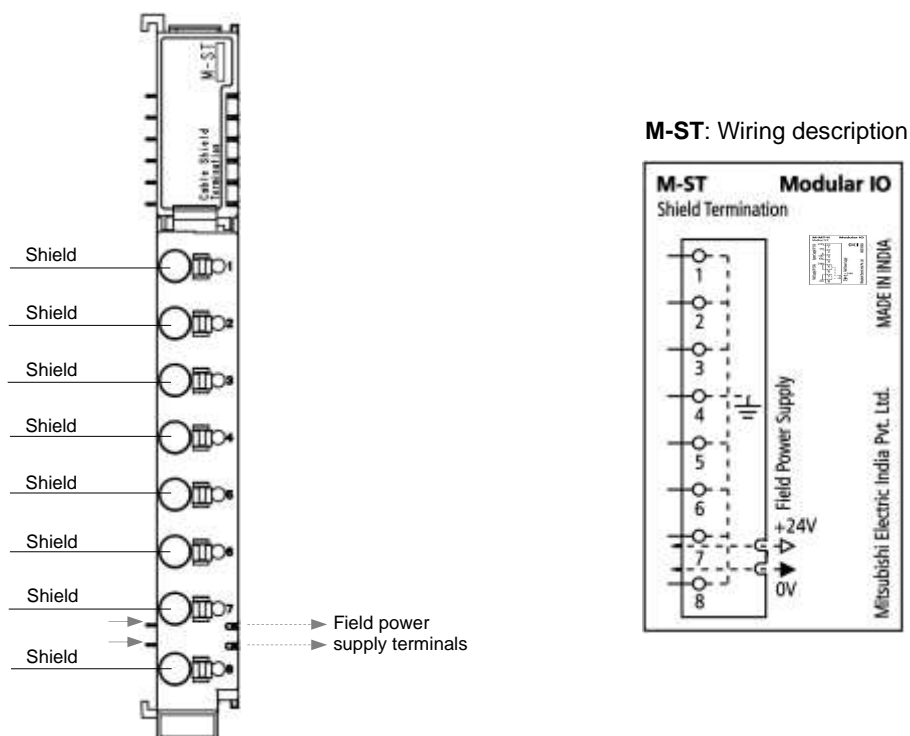

NOTE

All the 8 terminal of module M-ST are connected internally to DIN rail on which module IO station is mounted. It is necessary to ensure that DIN rail and control panel is connected to a proper Earth.

The figure below shows shield termination connections in a modular IO station when M-ST is used.

Shield termination module provides earth connection on the terminal block. User can connect cable shield of analog IO signals to this module.

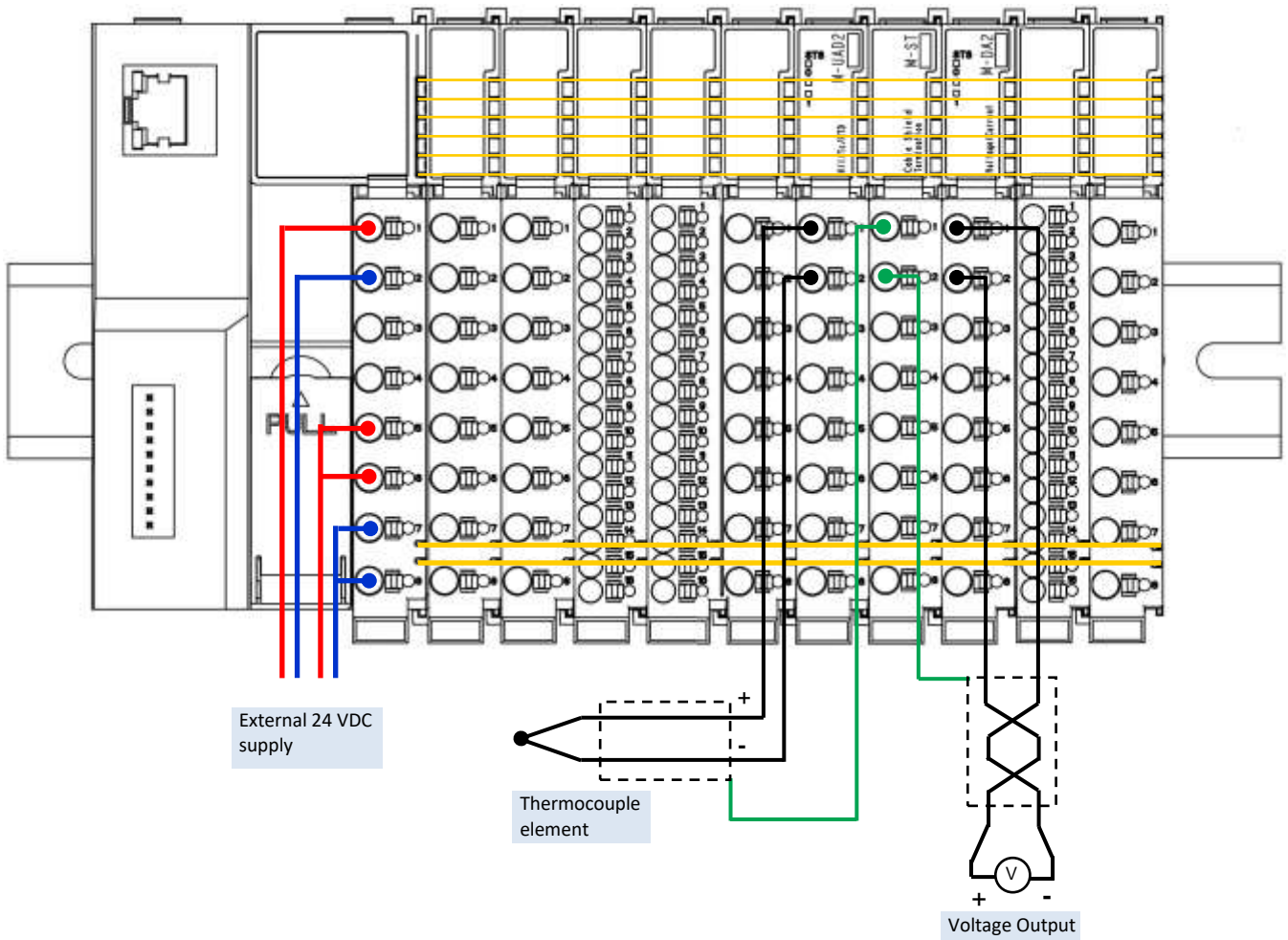

8.5 M-BE

[Bus End Module]

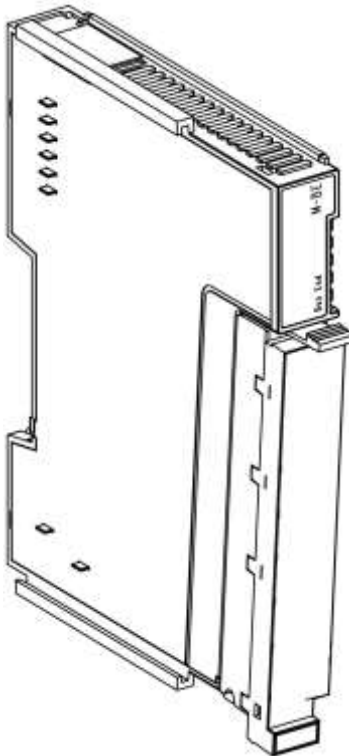

[Module Overview](#)

[Part Names](#)

[Specifications](#)

[Connection Diagram](#)

Module Overview

In a modular IO station, bus end module M-BE provides termination to backplane bus. User should attach bus end module M-BE at the last slot position if there are 16 or more IO modules.

Part Names

The figure below describes part names of the module.

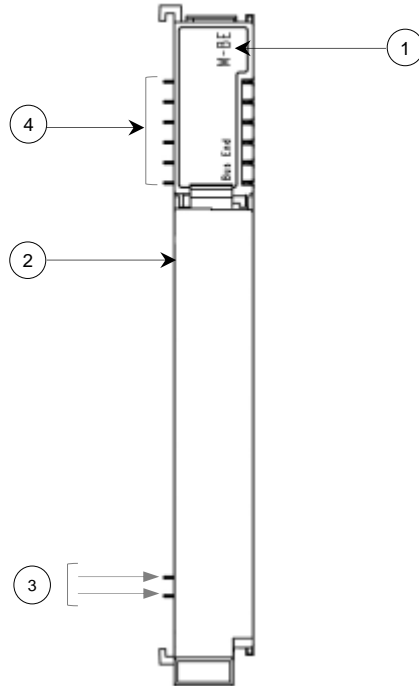

No.	Name	Description
1	M-BE	Module ordering code
2	Front Label	Fixed in place of terminal block
3	Field Power Supply Interface	2, Incoming pins for field power supply interface
4	System Power Supply Interface	6, Incoming pins for system power supply interface

NOTE

Bus End module M-BE does not provide outgoing pins for field power supply and system power supply.

Specifications

The table below provides technical specifications of **M-BE**.

Specification	Description
Module Ordering Code	M-BE
Terminating Resistor	120 Ω / QW
Power Dissipation	Nil
Module Dimensions (H x W x D) in mm	105 x 13.2 x 83

Connection Diagram

The figure shows module M-BE with front label fixed on it. Wiring description is provided on right side wall of the module.

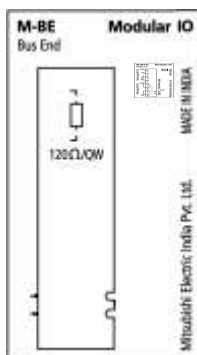

NOTE

M-BE does not require external connections.

The figure below shows modular IO station when M-BE is used.

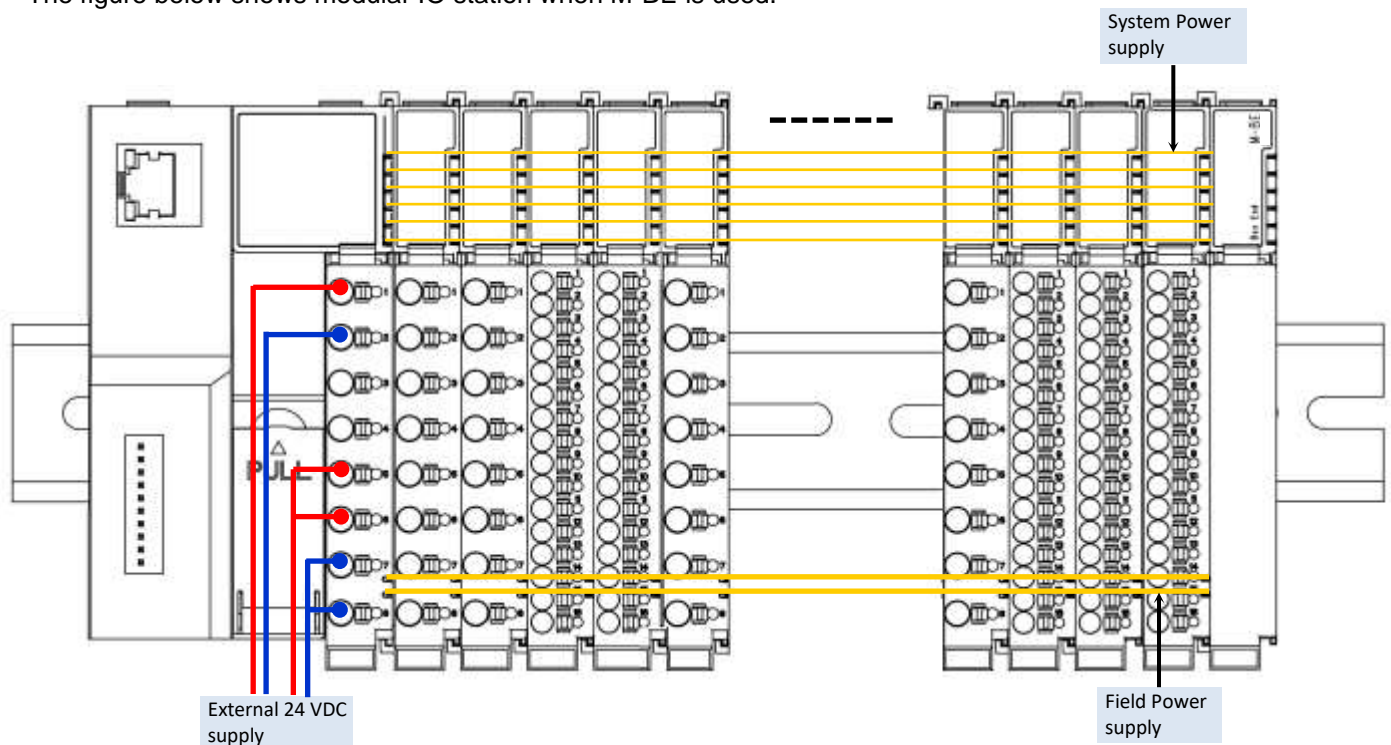

NOTE

User should attach Bus End module M-BE at the last slot position if there are 16 or more IO modules.

8.6 M-B2, M-B3, M-B5

[2-Slots, 3-Slots, 5-Slots Base Modules]

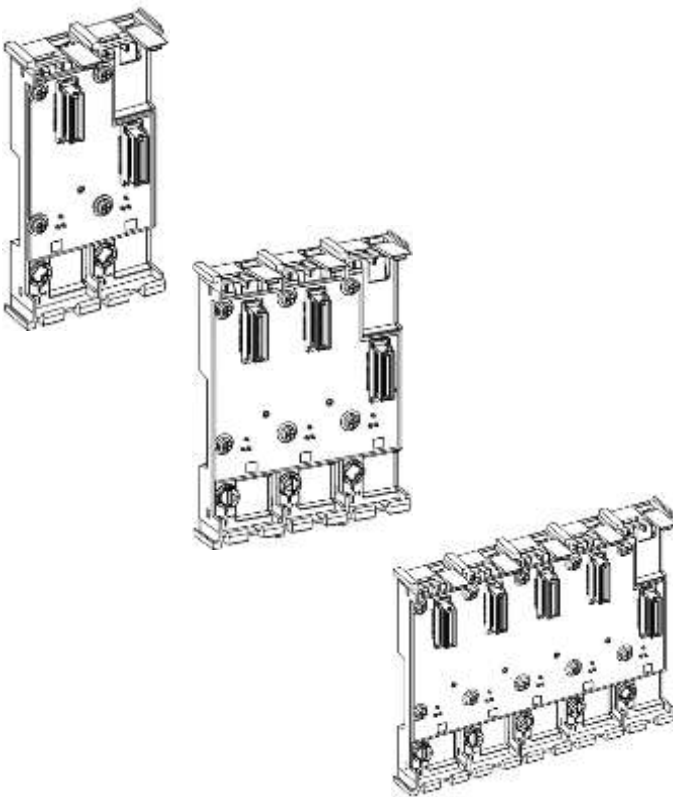

[Module Overview](#)

[Part Names](#)

[Specifications](#)

Module Overview

For Modular IO station with header assembly, assembly modules are mounted on base module.

Base module has following functions,

- Facilitates mounting on a DIN rail (35 x 7.5 x 1 mm).
- Facilitates fixing of header assembly modules on it.
- Supplies 5 Vdc from Power supply module to other modules fixed on it and to IO modules via adapter module.
- Provides backplane bus interface from Header module to IO modules via adapter module.
- Connects hand-shaking signals with the header assembly modules

Three variants of base module are available.

The table below explains base module variants and slots.

Base module	No. of slots	No. of PSU slots	No. of Header slots	No. of ADP slots
M-B2	2	1*	1	No
M-B3	3	1	1	1
M-B5	5	2	2	1

* For M-B2 (2-slot base module) power supply is inserted in right most slot and acts as adapter module also.

Part Names

The figure below describes part names of the M-B2 base module.

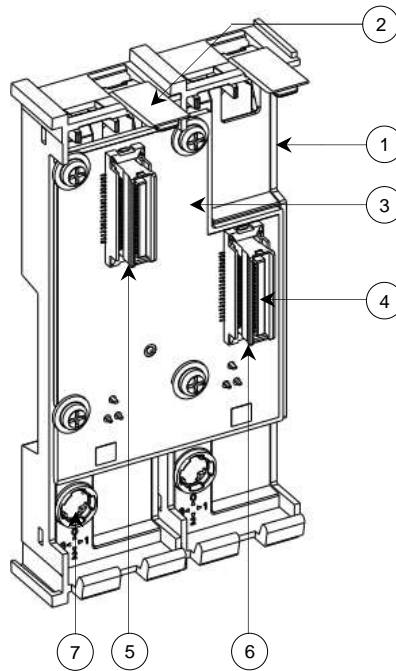

No.	Name	Description
1	Base Housing	Base housing that can be mounted on DIN rail.
2	DIN Clamp Levers	Operate lever (open/close) to unmount/ mount on DIN rail.
3	Backplane PCB	Backplane PCB provides module interface connectors on it and interconnections between Header assembly modules
4	Module Interface Connectors	Interface connectors for the modules in each slot.
5	PSU Slot P1	Mount Power Supply module (M-DPSU) in the slot.
6	Header Slot	Mount Header module (M-CCIEF-H) in the slot.
7	Slot Coding	Coding part fixed on base module and backside of header module to ensure desired module is allowed to fix in the slot.

The figure below describes part names of the M-B3 and M-B5 base modules.

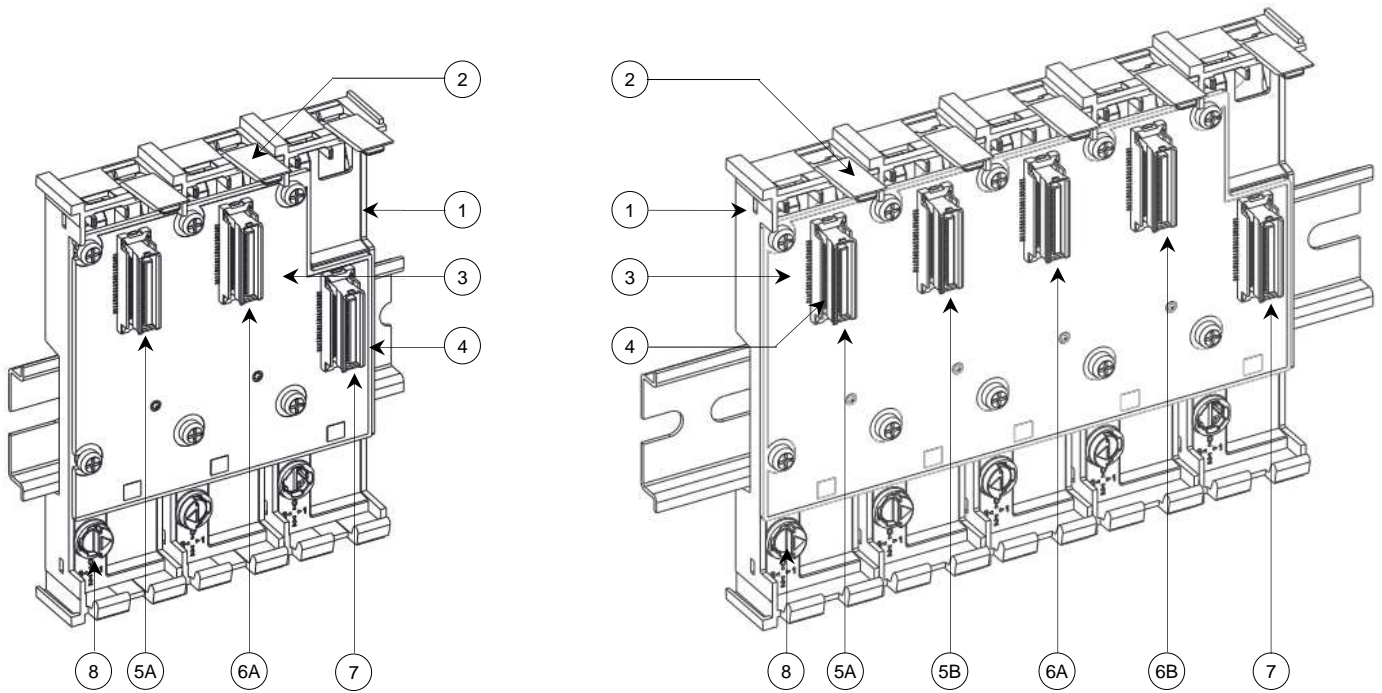

No.	Name	Description
1	Base Housing	Base housing that can be mounted on DIN rail.
2	Levers	Operate lever (open/close) to unmount/ mount on DIN rail.
3	Backplane PCB	Backplane PCB provides module interface connectors on it and interconnections between Header assembly modules
4	Module Interface Connectors	Interface connectors for the modules in each slot.
5A	PSU Slot P1	Mount Power Supply module (M-APSU) in the slot.
5B	PSU Slot P2	
6A	Header Slot H1	Mount Header module (M-CCIEF-H) in the slot.
6B	Header Slot H2	
7	ADP Slot	Mount I/O Adapter module (M-ADP) in the slot.
8	Slot Coding	Coding part fixed on base module and backside of power supply module and header module to ensure desired module is allowed to fix in the slot.

Specifications

The table below provides technical specifications of **M-B2**, **M-B3** and **M-B5**.

Item	Description		
	M-B2	M-B3	M-B5
Ordering Code	M-B2	M-B3	M-B5
Number of Slots	2	3	5
No. of PSU Slots	1	1	2
No. of Header Slots	1	1	2
No. of ADP Slots	No*	1	1
Mounting	DIN rail (35 x 7.5 x 1 mm)		
Dimensions (H x W x D) in mm	111 x 00 x 15	111 x 81 x 15	111 x 135 x 15
Weight (in grams)	00	85	150

* For M-B2 (2-slot base module) power supply is inserted in right most slot and acts as adapter module also.

8.7 M-APSU

[Redundant AC Power Supply, 3.5A Module]

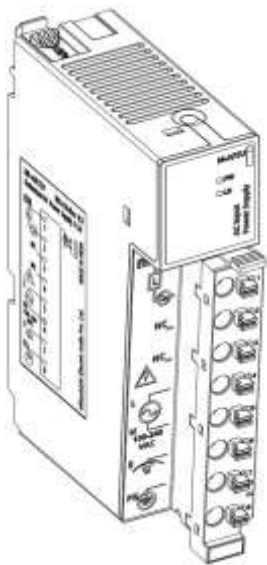

[Module Overview](#)

[Part Names](#)

[Specifications](#)

[LED Indications](#)

[Connection Diagram](#)

Module Overview

M-APSU is 110/220 VAC Input Power Supply module which is a Header assembly module. M-APSU module can be mounted in PSU slot of 3-slots base module (M-B3) and 5-slots base module (M-B5).

Power Supply module has following functions,

- Supplies 5 Vdc to other modules fixed Base module and to IO modules via Adapter module.
- To generate input supply ok and output supply ok signal to header module to ensure healthy start up after power ON and healthy shut down before power fail.
These signals help header module to provide status and diagnostic information in redundant configuration.

M-APSU module is designed for redundant operation and works on the principle of load sharing with another M-APSU module. User can configure and install two M-APSU modules on 5-slots base module (M-B5). If one module fails, another module continues to supply power to other modules and IO modules.

Module supports hot swapping to allow module replacement without system shut down or system disturbance. Two power supply modules in system ensure high availability, means the system is less likely to experience downtime due to power supply issues.

NOTE

Modular M-APSU is not an intelligent module.

Module provides necessary status and diagnostic information to user using LED indication, via header status and diagnostics and potential free ERR relay contact output.

Part Names

The figure below describes part names of the M-APSU module.

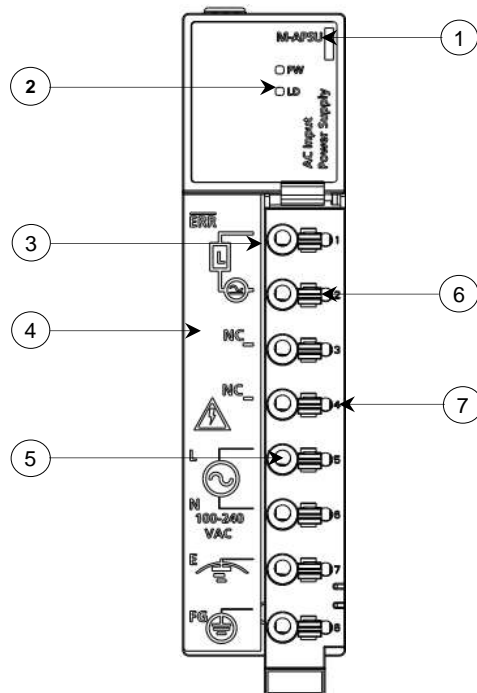

No.	Name	Description
1	M-APSU	Module ordering code
2	Module LED Indications	PW: 1 no., Green coloured LED for module power status LD: 1 no., Amber coloured LED to indicate overcurrent (> 4.5 Amp) observed at output.
3	Terminal Block	8-point removable push type
4	Connection details	Connection details
5	IO Point	Wire insertion point on IO terminal
6	Push Button	Press to release wire
7	Test Point	To measure signal voltage

NOTE

It is recommended to connect fast blow fuse in series with contact externally to avoid damage to contact output circuit due to overload or short circuit at supply end.

Mechanical coding on base module and M-APSU module ensures that M-APSU module can be mounted in PSU slot only.

Specifications

The table below provides technical specifications of **M-APSU**.

Specification		Description	
Module Ordering Code		M-APSU	
Mounting		On Base module M-B3 and M-B5	
Position on Base Module		PSU slot on base module	
Input Voltage		100 to 240 VAC (Range from 85 to 264 VAC)	
Input Frequency		50/ 60 Hz -6%/ +4%	
Maximum Input Apparent Power		90 VA	
Inrush Current		20 A, 8 ms or less	
Rated Output Voltage		5 VDC; 3.5 A (2A for IO modules)	
Parallel Connection		Permitted for redundancy operation with load sharing.	
Allowable Momentary Power Failure		>20 ms at 220 VAC at full load at an ambient of 55 °C >10 ms at 110 VAC at full load at an ambient of 55 °C	
Protection	Output over current	4.4 A or higher	
	Output short circuit	Yes	
	Input overvoltage	Yes	
	Internal fuse at input side	Built-in (Unchangable by user)	
	Over temperature	Yes	
Potential Free Contact Output	Application	ERR contact	
	Rated switching voltage current	220 VAC/ 24 VDC, 0.5 A	
	Minimum switching load	1 mA	
	Response time	Off to On	10 ms or less
		On to Off	10 ms or less
	Life	Mechanical	20 million times max. (180 cpm)
		Electrical	100,000 times max.
	Surge suppressor	None	
Fuse protection	None		
Module status indication		PW: 1 no., Green LED LD: 1 no., Amber LED	
Withstand voltage (EN 50178)		2300 VAC rms per minute (Between line input terminals and FG terminals and output)	
Insulation resistance		100 MΩ or higher by 500 VDC insulation resistance tester (between line input terminals and FG terminals and output)	
Hot swapping		Supported.	
Terminal Block (Removable push type)		8-point	
Recommended Wire Size		0.5 sq. mm to 2.0 sq. mm (AWG 20 to 14), Solid wire or Stranded (flexible) wire with lugs	
Dimensions (H x W x D) in mm		111 x 27 x 80	
Weight (in grams)		128	

LED Indications

This section provides meanings of LED indications available on module.

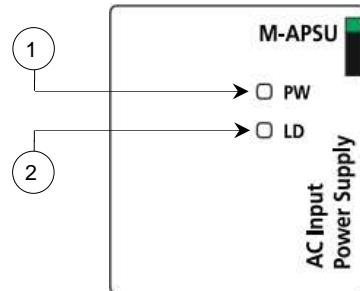

No.	LED	Colour	Status	Description
1	PW	Green	OFF ^{*1}	Following are the causes due to AC input fault, <ul style="list-style-type: none"> - AC input is not connected. - AC input in below specified range. - In-built fuse is blown. Following are the causes due to DC output fault, <ul style="list-style-type: none"> - Short circuit at 5 VDC output. - Over current at 5 VDC output. - Over temperature.
			ON	Supply output of 5Vdc is healthy.
2	LD	Amber	OFF	External load at 5Vdc output is up to 3.5 Amps.
			ON	External load at 5Vdc output is greater than 3.5 Amps.

^{*1} ERR contact can be used to operate relay or contactor externally and wire its contact for alarm purpose and safety interlock purpose in control circuit.

NOTE

Redundant power supply module provides necessary status and diagnostics using either LED indications or with ERR relay contact output or by internal signals to Header module.

Connection Diagram

The figure shows the front view of M-APSU module with 8-point terminal block. Wiring description is provided on front side of the module as well as left side wall of the module.

For common wiring recommendations, refer section [Wiring](#).

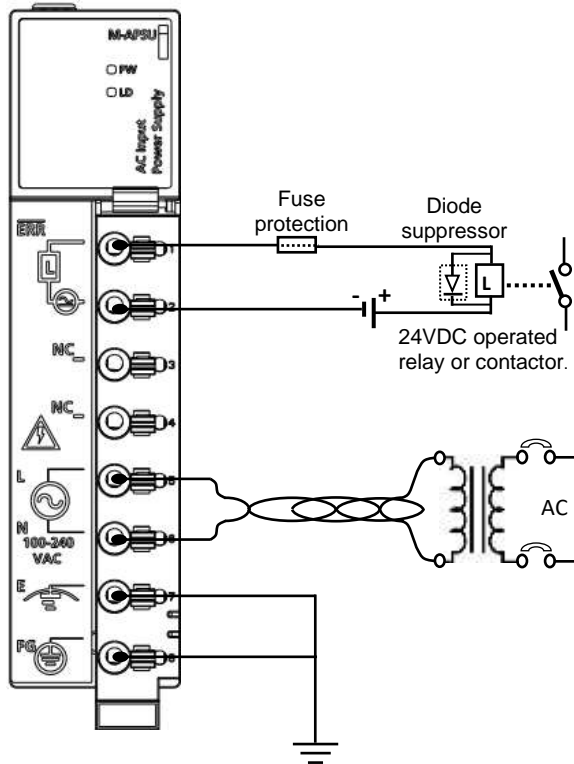

M-APSU: Wiring description

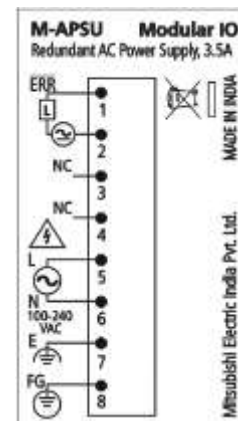

Terminal No.	Description
1, 2	Connect external 220 VAC or 24 VDC operated relay or contactor.
3, 4	Not connected
5, 6	Connect AC power supply input of rating 100 – 240 VAC, 90 VA.
7	Connect good quality EARTH at (E terminal). If not, it may result in electric shock or erroneous operations.
8	Connect frame ground at (FG terminal) properly. If not, product may be susceptible to noise.

NOTE

It is recommended to connect RC snubber or MOV suppressor (for AC load) and free-wheeling diode (for DC load) in parallel with load externally to avoid inductive surges and damage to ERR contact output circuit.

Connect fast blow fuse in series with contact externally to avoid damage to contact output circuit due to overload or short circuit.

ERR relay contact is closed when conditions pertaining to the ON status of PW LED indication are fulfilled.

ERR relay contact becomes open in the following cases,

- AC input is not connected, or AC input is below the specified range
- In-built fuse is blown off
- Short circuit or over current at 5 VDC output or over temperature
- Header module is in STOP mode or RESET mode.

8.8. M-DPSU

[24VDC Power Supply, 3A Module]

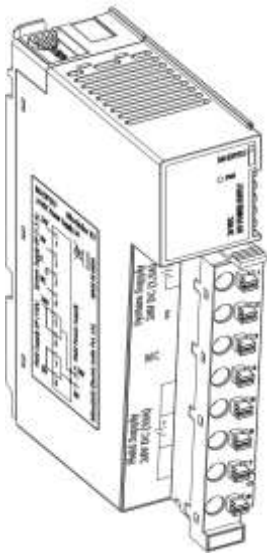

[Module Overview](#)

[Part Names](#)

[Specifications](#)

[LED Indications](#)

[Connection Diagram](#)

Module Overview

M-DPSU is 24 VDC Input Power Supply module which is a Header assembly module. M-DPSU module can be fixed in rightmost slot of 2-slots base module (M-B2).

Power Supply module has following functions,

- Supplies 5 Vdc to other modules fixed Base module and to IO modules.
- To generate input supply ok and output supply ok signal to header module to ensure healthy start up after power ON and healthy shut down before power fail.
These signals help header module to provide status and diagnostic information in redundant configuration.
- Provides backplane connector interface on the right-side wall of the module and facilitates attachment of IO modules. It forwards backplane bus signals from base module to the attached IO modules.
- Provides connection of 24 VDC field power supply on the terminal block and provides it to the attached IO modules.

NOTE

Modular M-DPSU is not an intelligent module.

Module provides necessary status and diagnostic information to user using LED indications and via header status and diagnostics.

This module does not permit load sharing operation with any other power supply module

Part Names

The figure below describes part names of the M-DPSU module.

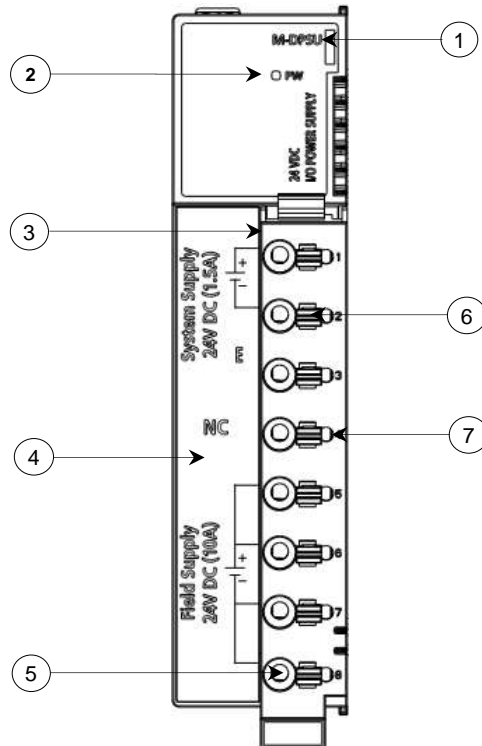

No.	Name	Description
1	M-DPSU	Module ordering code
2	Module LED Indications	PW: 1 no., Green LED for module power status
3	Terminal Block	8-point removable push type
4	Connection details	Connection details
5	IO Point	Wire insertion point on IO terminal
6	Push Button	Press to release wire
7	Test Point	To measure signal voltage

NOTE

The current carrying capacity of each terminal of terminal block is maximum 5 Amps. Field power supply interface between modules has a current carrying capacity of 10 Amps.

It is mandatory to connect 2 wires from the source of field power supply to utilize maximum capacity of 10 A.

Specifications

The table below provides technical specifications of **M-DPSU**.

Specification		Description
Module Ordering Code		M-DPSU
Mounting		On Base module M-B2
Position on Base Module		PSU slot on base module
Input Voltage		24 VDC (Range from 18 to 30 VDC)
Maximum input power		20 Watts
Inrush current		70 Amps, for 500 micro sec or less
Startup time at full load		Less than 30 ms
Rated output voltage		5 VDC; 3 A (2A for IO modules)
Output ripple		20 mV (p – p) maximum
Efficiency		80% or greater
Line regulation & load regulation		90 mV maximum
Allowable momentary power failure		Less than 10 ms at 24 VDC at full load at an ambient of 55 °C
Protection	Output over current	Yes. 3.9 Amps or higher
	Output short circuit	Yes
	Input polarity reversal	Yes
	Input transient	Yes
	Input overvoltage	Yes
	Internal fuse at input side	Yes. Built-in (Unchangable by user)
Over temperature		Supported
Module status indication		1 no., Green LED (PW)
Module status and diagnostics		LED indication for local monitoring.
I/O memory consumption		Nil
Withstand voltage	Between primary and 5VDC terminal	510 VAC per minute;
Insulation resistance	Between line input terminals and output)	100 MΩ or higher by 500 VDC insulation resistance tester
Hot swapping		Not supported
Terminal Block (Removable push type)		8-point
Recommended Wire Size		0.5 sq. mm to 2.0 sq. mm (AWG 20 to 14), Solid wire or Stranded (flexible) wire with lugs
Dimensions (H x W x D) in mm		111 x 27 x 67
Weight (in grams)		125

LED Indications

This section provides meanings of LED indications available on module.

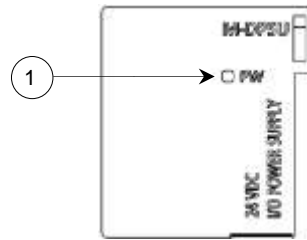

No.	LED	Colour	Status	Description
1	PW	Green	OFF	<p>Following are the causes due to DC input fault,</p> <ul style="list-style-type: none"> - DC input is not connected. - DC input in below specified range. ^{*1} - In-built fuse is blown. <p>Following are the causes due to DC output fault,</p> <ul style="list-style-type: none"> - Short circuit at 5 VDC output. - Over current at 5 VDC output. - Over temperature.
			ON	Supply output of 5Vdc is healthy.

NOTE

^{*1} DC input lower range can be detected below 18 VDC but healthy output 5 VDC may get generated with input voltage much lower than 18 VDC.

Connection Diagram

The figure shows the front view of M-DPSU module with 8-point terminal block. Wiring description is provided on front side of the module as well as left side wall of the module.

For common wiring recommendations, refer section [Wiring](#).

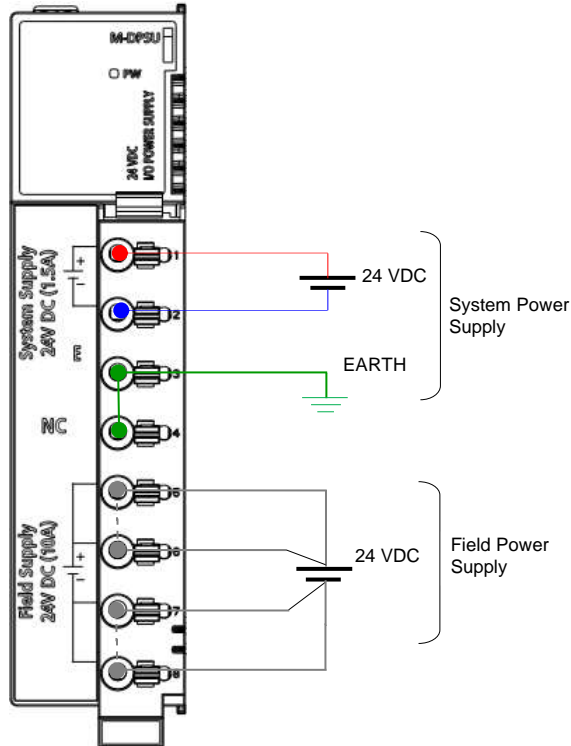

M-DPSU: Wiring description

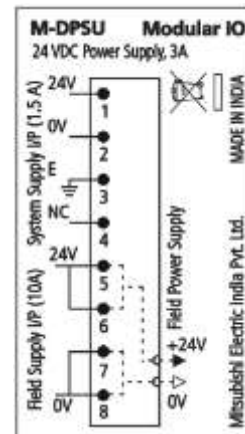

NOTE

Ensure that EARTH cable is thick and short as far as possible to provide a low impedance path.

8.9 M-ADP

[I/O Adapter Module]

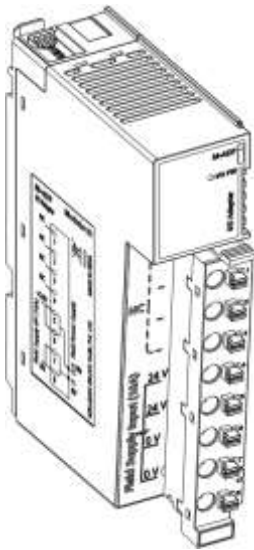

[Module Overview](#)

[Part Names](#)

[Specifications](#)

[LED Indications](#)

[Connection Diagram](#)

Module Overview

M-ADP is I/O Adapter module which is a Header assembly module. M-ADP module can be mounted in ADP slot i.e. the rightmost slot on 3-slots base module (M-B3) and 5-slots base module (M-B5).

I/O Adapter module has following basic functions,

- Allows the attachment of I/O modules to the Header assembly.
- Interfaces the 5 VDC supply and backplane bus from the base module to the connected I/O modules.
- Supplies field power to the connected I/O modules.

Part Names

Below figure describes part names of the module.

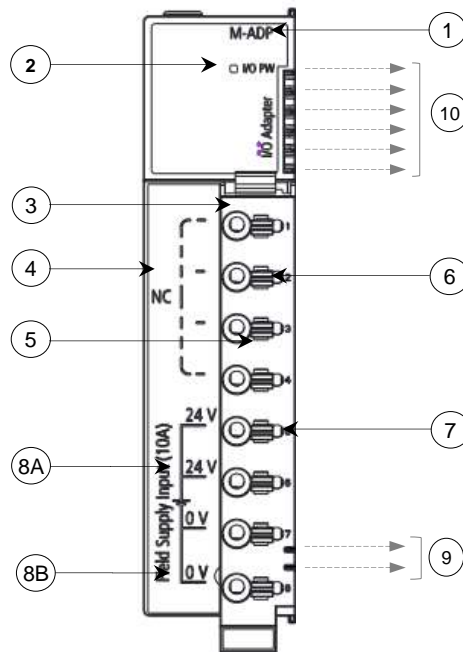

No.	Name	Description
1	M-ADP	Module ordering code
2	Module LED Indication	1 no., I/O PW, Green LED for field power supply status
3	Terminal Block	8-point removable push type
4	Connection details	Connection details
5	IO Point	Wire insertion point for IO terminal
6	Push Button	Press to release wire
7	Test Point	To measure signal voltage
8A	+24 Vdc Terminals for Field Power Supply Input	Connect +24 VDC of field power supply to terminal numbers 5 and 6.
8B	0 Vdc Terminals for Field Power Supply Input	Connect field power supply ground to terminal numbers 7 and 8.
9	Field Power Supply Interface	2 Outgoing pins for field power supply interface for the IO module attached.
10	System Power Supply Interface	6 Outgoing pins for system power supply interface for the IO module attached.

Specifications

The table below provides technical specifications of **M-ADP**.

Specification	Description
Module Ordering Code	M-ADP
Mounting	On Base module M-B3 and M-B5
Position On Base	ADP slot i.e. rightmost slot on base module
LED Indication	I/O PW Green LED: 24 VDC field power supply is healthy
Contact Current at Terminal	5 A per input terminal
Terminal Block (Removable push type)	8-point
Recommended Wire Size	0.5 sq. mm to 2.0 sq. mm (AWG 20 to 14), Solid wire or Stranded (flexible) wire with lugs
Module Dimensions (H x W x D) in mm	111 x 27 x 80
Weight (in grams)	96

LED Indications

This section provides meanings of LED indications available on module.

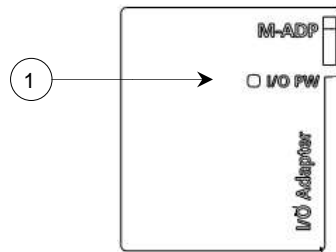

No.	LED	Colour	Status	Description
1	I/O PW	Green	OFF	Field power supply 24 VDC is absent.
			ON	Field power supply 24 VDC is healthy.

Connection Diagram

The figure shows the front view of M-ADP module with 8-point terminal block. Wiring description is provided on front side of the module as well as left side wall of the module.

For common wiring recommendations, refer section [Wiring](#).

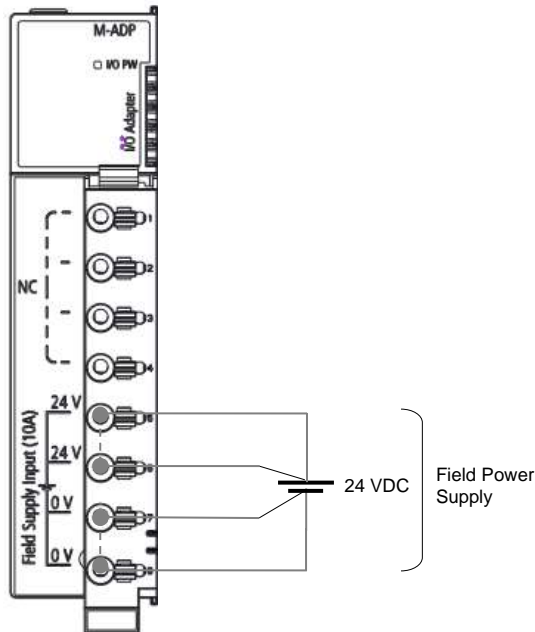

M-ADP: Wiring description

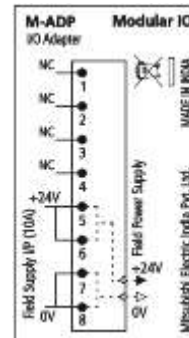

NOTE

Current carrying capacity of each terminal of terminal block is 5 A max. Field power supply interface between modules has current carrying capacity of 10 A. So, it is mandatory to connect 2 wires from source of field power supply to utilize maximum capacity of 10 A. Field power supply connected to terminal block is directly carried to field power supply pins for interfacing with IO modules.

8.10 M-BC

[Blank Cover Module]

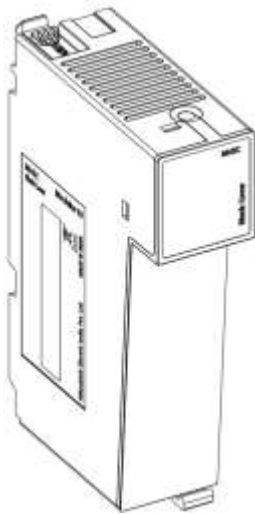

[Module Overview](#)

[Part Names](#)

[Specifications](#)

[Connection Diagram](#)

Module Overview

In a modular IO station, blank cover module M-BC has no external connections. User should attach blank cover module M-BC at the last slot position in Header assembly configuration.

Part Names

Below figure describes part names of the module.

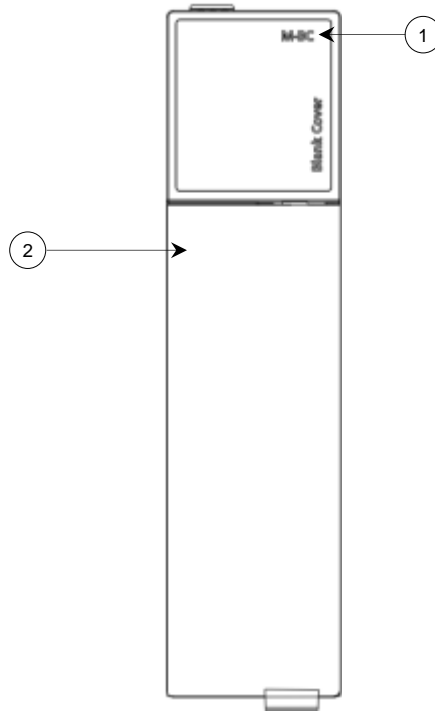

No.	Name	Description
1	M-BC	Module ordering code
2	Front Cover	Fixed in place of terminal block

Specifications

The table below provides technical specifications of **M-BC**.

Specification	Description
Module Ordering Code	M-BC
Mounting	On base module (M-B5)
LED Indication	Not available
Connection	Not supported
Module Dimensions (H x W x D) in mm	111 x 27 x 80
Weight (in grams)	50 gm

Connection Diagram

The figure shows module M-BC with front label fixed on it. Wiring description is provided on right side wall of the module.

**NOTE**

M-BC does not require external connections.

9 Special Function Modules

2 Channel Serial COM [RS 232] Module	M-2R2
1 Channel Serial COM [RS 232] Module	M-1R2
1 Channel Serial COM [RS422/485] Module	M-1R4

9.1 M-2R2

[2 Ch. Serial COM (RS232) Module]

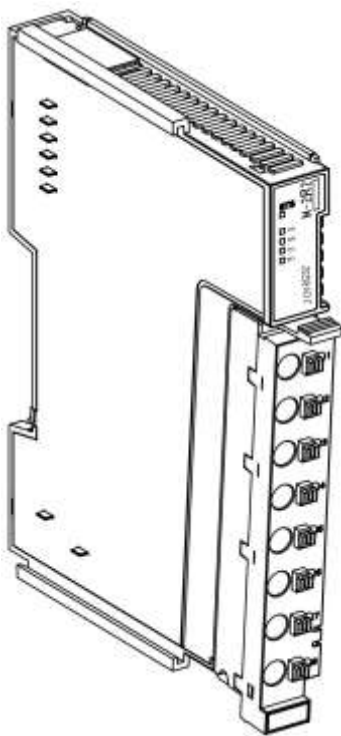

[Module Overview](#)

[Part Names](#)

[Specifications](#)

[LED Indications](#)

[Connection Diagram](#)

[Parameters](#)

[IO Data](#)

[Example: Transmit and Receive](#)

Module Overview

M-2R2 is 2 channel serial communication module. It provides RS232 full duplex serial communication channels. The module can be fixed in any IO slot of modular IO station.

Considering methodology of serial communication over fieldbus network, handling simple protocols like ASCII protocol will be easier from application program perspective. It is recommended to interface serial devices like bar code scanner, RFIDs, printers, etc. Refer section [Transmit and receive example](#) which provides more information of IO data with example.

Fieldbus network cycle time is a major factor to decide effective throughput of module. Typically, 100 bytes can be transmitted / received at an interval of 600 msec at baud rate of 9600 bps and network cycle time of 10 msec.

Part Names

The figure below describes part names of the module.

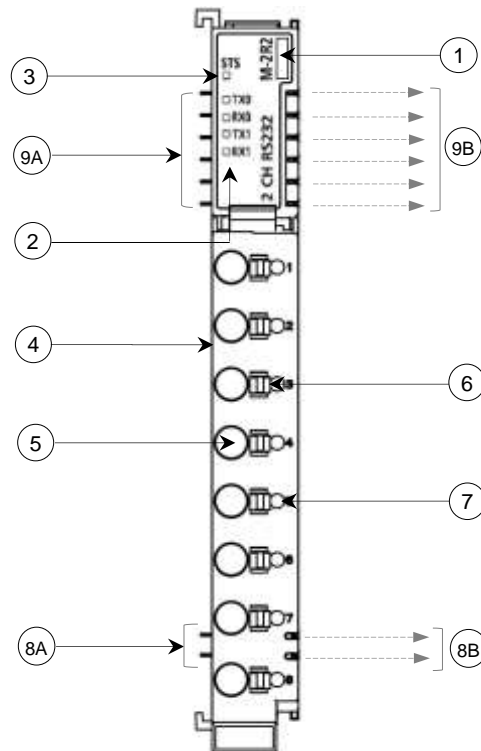

No.	Name	Description
1	M-2R2	Module ordering code
2	Channel LED Indications	TX0, TX1: Transmit signal lines RX0, RX1: Receive signal lines
3	Module Status LED Indication	STS: 1 Bi-colour LED for module status
4	Terminal Block	8-point removable push type
5	IO Point	Wire insertion point
6	Push Button	Press to release wire
7	Test Point	To measure signal voltage
8A	Field Power Supply Interface	2 Incoming pins for field power supply interface
8B		2 Outgoing pins for field power supply interface
9A	System Power Supply Interface	6 Incoming pins for system power supply interface
9B		6 Outgoing pins for system power supply interface

Specifications

The table below provides technical specifications of **M-2R2**.

Specification		Description
Ordering Code		M-2R2
Hardware Interface		RS232
Communication Type		Full duplex
Number of channels		2
Supported baud rate (in bps)		2400,4800,9600 [Default],19200,38400, 57600,115200
Receive Buffer size		512 bytes per channel
Transmit Buffer Size		256 bytes per channel
Input Image Size		16 bytes (8 bytes per channel)
Output Image Size		16 bytes (8 bytes per channel)
Length of Cable		15 meters maximum
LED Indications		1 no. bicolor LED (red + green) for module status Indication. 4 nos. LEDs (green) for channel indication, TX0, RX0 : For channel 0 TX1, RX1 : For channel 1
High Signal Voltage		+18 VDC to +3 VDC
Low Signal Voltage		-18 VDC to -3 VDC
Maximum Signal Voltage		±40 VDC
Backplane Current Consumption		50 mA
Field Power Supply Consumption		40 mA
Terminal Block (Removable push type)		8 point
Isolation		Between communication port and internal circuit Optical 2.5 KV RMS
IO memory consumption	Input Bytes (IW)	16 bytes
	Output Bytes (QW)	16 bytes
	Diagnostic (SB) [User configurable]	1 byte
I/O terminals		TX, RX, GND, SHLD (for each channel)

Refer section [Wiring](#) for more details.

NOTE

Module M-2R2 is supported in Modular IO Configurator Tool [V1.4.0.0] and Header (M-CCB-H and M-MT-H) firmware [V01.02.00.00], Header (M-EIP-H) firmware [V01.01.00.00] and onwards.

LED Indications

This section provides meaning of LED indications available on module.

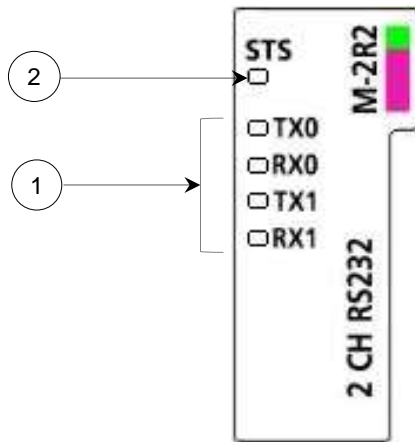

No.	*LED	Colour	Status	Description	
1	TX0	Green	ON	TX0 Signal is high	
			OFF	TX0 Signal is low	
	RX0		ON	RX0 Signal is high	
			OFF	RX0 Signal is low	
	TX1		ON	TX1 Signal is high	
			OFF	TX1 Signal is low	
	RX1		ON	RX1 Signal is high	
			OFF	RX1 Signal is low	
2	STS	Bi-colour LED	None	Module is powered OFF.	
			Blue Green	ON	Module is powered ON and communicating with Header module
				Single flash	Communication with Header is not established due to, <ul style="list-style-type: none"> - Module is powered ON and waiting for communication from Header. - Module mismatch
			Red	ON	Hardware failure is detected on module.
				Single flash	One of the following conditions occurred. <ul style="list-style-type: none"> - No communication from Header - Backplane bus fault detected.
				Double flash	<ul style="list-style-type: none"> - Parity Error occurred at CH0 or CH1. - Framing Error occurred at CH0 or CH1. - Overrun Error occurred at CH0 or CH1
			Yellow	ON	24 VDC field power supply is not available.

*For more details of LED indication states and flashing rates, refer section [Troubleshooting >> LED indications: States and flashing rates](#) in this manual.

Connection Diagram

The figure shows module front with 8 point terminal block, to interface serial communication module and external devices, to establish communication.

Wiring description is provided on right side wall of the module.

The figures below shows connections for channel 0, for an example.

For common wiring recommendations, refer section [Wiring](#).

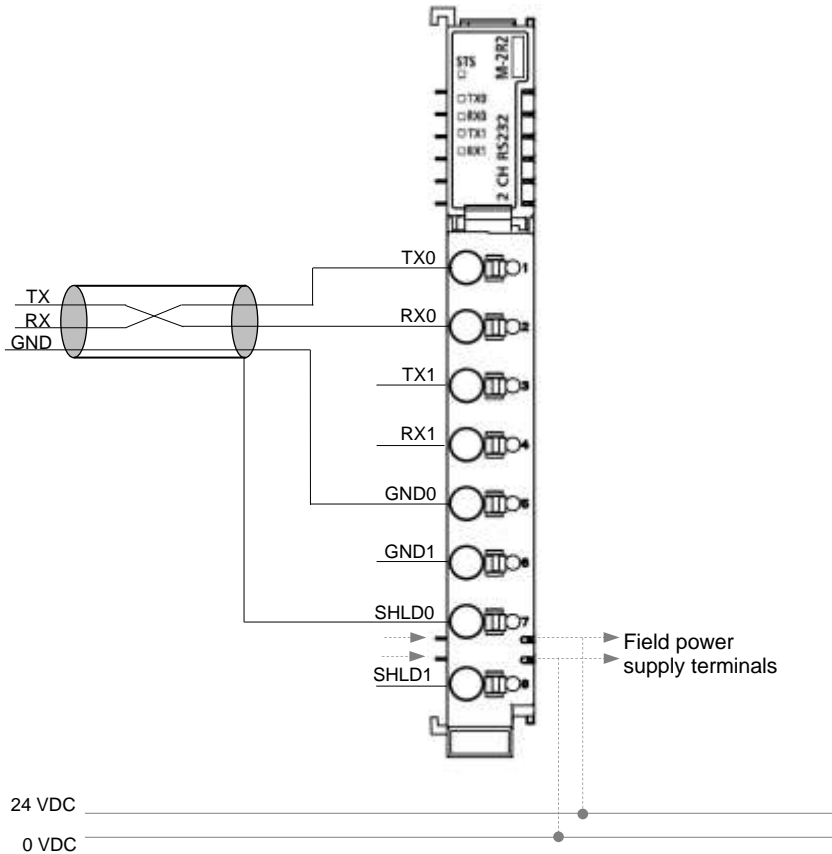

M-2R2: Wiring description

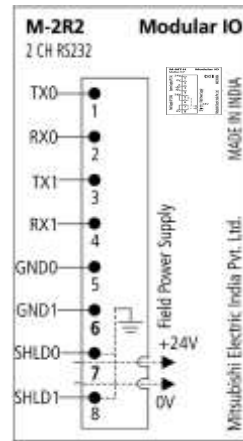

NOTE

Recommended length of RS232 serial communication cable is maximum up to 15 meters.

Parameters

Module can be configured using Modular IO Configurator.

For addition and removal of module in configuration tool, refer section [Modular IO Configurator](#).

User can set following parameters.

Parameter Name	Project Value	Comment
Share diagnostics	Enable [Default]	Enables diagnostic data (SB) sharing with header
	Disable	

Module diagnostic data and channel diagnostic data is available in Status Byte (SB) memory, if module parameter “Share diagnostics” is set to Enable.

The table below provides a list of channel parameters that user can set for individual channel.

Parameter Name	Project Value	Comment
Enable	Yes [Default] No	Enable/ disable channel
Baud rate	2400 4800 9600 [Default] 19200 38400 57600 115200	Communication baud rate
Parity	None Odd [Default] Even	Parity selection
No. of data bits	7 bits 8 bits [Default] 9 bits	Number of data bits
No. of stop bits	1 bit [Default] 2 bits	Number of stop bits

For more functional details, refer [Transmit and Receive Example](#) provided in this manual.

IO Data

Following table provides description for input data and output data.

Channel	Data Type	Local Address*
CH0	BYTE	IW n (BYTE 0)
	BYTE	QW m (BYTE 0)
CH1	BYTE	IW n+4 (BYTE 0)
	BYTE	QW m+4 (BYTE 0)

*Local address (n) and (m) values changes as per the slot position of IO module and configuration of modular IO station.

For serial communication module,

IW memory holds status information and received data as shown below.

	IWn.7	IWn.6	IWn.5	IWn.4	IWn.3	IWn.2	IWn.1	IWn.0
IWn Byte 0	TXA	RL2	RL1	RL0	TBO	RRBA	WTBA	INITA
IWn Byte 1	Read byte 1							
IWn+1 Byte 0	Read byte 2							
IWn+1 Byte 1	Read byte 3							
IWn+2 Byte 0	Read byte 4							
IWn+2 Byte 1	Read byte 5							
IWn+3 Byte 0	Read byte 6							
IWn+3 Byte 1	Read byte 7							

Channel	Data Type	Local Address*	Status	Comment
Input Data CH0*				
INITA (Init Ack)	BOOL	IWn (BYTE 0).0	TRUE	Initialisation Acknowledge. Module sends acknowledgement of INIT command received from fieldbus master using this bit.
			FALSE	Channel is ready for serial communication.
WTBA (Write TX Buffer Ack)	BOOL	IWn (BYTE 0).1	Change of state [0 → 1 or 1 → 0]	Write Transmit Buffer Acknowledge. Module sends acknowledgement of WTB command received from fieldbus master using this bit. Status of WTB is copied to WTBA, after successful writing to transmit buffer of module.
RRBA (Read RX Buffer Ack)	BOOL	IWn (BYTE 0).2		Read Receive Buffer Acknowledge. Module sends acknowledgement of RRB command received from fieldbus master using this bit. Status of RRB is copied to RRBA after successful reading from receive buffer of module.
TBO (TX Buffer Overflow)	BOOL	IWn (BYTE 0).3		Transmit Buffer Overflow. Transmit buffer of module is full. After transmit buffer overflow, additional bytes received on serial communication are lost. Transmit buffer size is 256 bytes per channel.

RL0.....RL2 (Receive Length bit 0 to Receive Length bit 2)	BOOL	IWn (BYTE 0).4 to IWn (BYTE 0).6	--	<p>Read Length for Read Receive Buffer command Number of bytes read from receive buffer of module. Maximum length is 7 bytes.</p> <table border="1"> <thead> <tr> <th>RL2</th> <th>RL1</th> <th>RL0</th> <th>Read Length (in Bytes)</th> </tr> </thead> <tbody> <tr><td>0</td><td>0</td><td>0</td><td>0</td></tr> <tr><td>0</td><td>0</td><td>1</td><td>1</td></tr> <tr><td>0</td><td>1</td><td>0</td><td>2</td></tr> <tr><td>0</td><td>1</td><td>1</td><td>3</td></tr> <tr><td>1</td><td>0</td><td>0</td><td>4</td></tr> <tr><td>1</td><td>0</td><td>1</td><td>5</td></tr> <tr><td>1</td><td>1</td><td>0</td><td>6</td></tr> <tr><td>1</td><td>1</td><td>1</td><td>7</td></tr> </tbody> </table>	RL2	RL1	RL0	Read Length (in Bytes)	0	0	0	0	0	0	1	1	0	1	0	2	0	1	1	3	1	0	0	4	1	0	1	5	1	1	0	6	1	1	1	7
RL2	RL1	RL0	Read Length (in Bytes)																																					
0	0	0	0																																					
0	0	1	1																																					
0	1	0	2																																					
0	1	1	3																																					
1	0	0	4																																					
1	0	1	5																																					
1	1	0	6																																					
1	1	1	7																																					
TXA (Transmit Ack)	BOO L	IWn (BYTE 0).7	Change of state [0 → 1 or 1 → 0]	<p>Transmit Acknowledge. Module sends acknowledgement of TX command received from fieldbus master using this bit. Once data transmission is complete, status of TX is copied to TXA.</p>																																				
RD Byte 1	BYTE	IWn (BYTE 1)	--	Read Data byte 1.																																				
RD Byte 2	BYTE	IWn+1 (BYTE 0)	--	Read Data byte 2.																																				
RD Byte 3	BYTE	IWn+1 (BYTE 1)	--	Read Data byte 3.																																				
RD Byte 4	BYTE	IWn+2 (BYTE 0)	--	Read Data byte 4.																																				
RD Byte 5	BYTE	IWn+2 (BYTE 1)	--	Read Data byte 5.																																				
RD Byte 6	BYTE	IWn+3 (BYTE 0)	--	Read Data byte 6.																																				
RD Byte 7	BYTE	IWn+3 (BYTE 1)	--	Read Data byte 7.																																				

*Similarly, input data for CH1 is mapped from IWn+4 to IWn+7.

QW memory holds control information and transmit data as shown below.

	QWm.7	QWm.6	QWm.5	QWm.4	QWm.3	QWm.2	QWm.1	QWm.0
QWm Byte 0	TX	WL2	WL1	WL0	RES	RRB	WTB	INIT
QWm Byte 1	Write byte 1							
QWm+1 Byte 0	Write byte 2							
QWm+1 Byte 1	Write byte 3							
QWm+2 Byte 0	Write byte 4							
QWm+2 Byte 1	Write byte 5							
QWm+3 Byte 0	Write byte 6							
QWm+3 Byte 1	Write byte 7							

Channel	Data Type	Local Address*	Status	Comment
Output Data CH0*				
INIT (Init)	BOOL	QWm (BYTE 0).0	TRUE	<p>Initialisation command.</p> <p>Fieldbus master can generate request to reset channel using this bit.</p> <p>When this bit is ON, channel is initialised.</p> <p>When initialised, module takes following actions,</p> <ol style="list-style-type: none"> 1. FIFO pointers of TX buffer and RX buffer are initialised 2. Channel port is initialised with communication parameters set. 3. Errors are cleared. (Overrun, parity, framing) 4. Acknowledge status bits in input image are cleared. (WTBA, RRBA) 5. Status of INITA in input image is turned ON indicating successful initialisation.
			FALSE	No initialisation request is issued. Channel is ready for serial communication.
WTB (Write TX Buffer)	BOOL	QWm (BYTE 0).1	Change of state [0 → 1 or 1 → 0]	<p>Write Transmit Buffer command.</p> <p>Fieldbus master can generate command to write data to transmit buffer of module using this bit.</p> <p>When module receives change of state of this bit, module does following actions,</p> <ol style="list-style-type: none"> 1. Check size of data to write to transmit buffer in 'WL0 to WL2' 2. Write data received in 'WR Byte 1'to WR Byte 7' to transmit buffer of module as per write length. If write length is 0, then no data is written to transmit buffer. <p>Maximum 7 bytes data can be written with single command.</p> <p>3. Status of WTBA in input image is updated indicating successful write operation. Status of WTB is copied to WTBA.</p>

RRB (Receive RX Buffer)	BOOL	QWm (BYTE 0).2		<p>Read Receive Buffer command.</p> <p>Fieldbus master can generate command to read data from receive buffer of module using this bit.</p> <p>When module receives state change on this bit, module does following actions,</p> <ol style="list-style-type: none"> 1. Checks if any data is present in its RX buffer. 2. If data is present in receive buffer, copy data from RX buffer to input image 'RD Byte 1' to 'RD Byte 7'. Data is copied on FIFO basis. <p>Maximum 7 bytes data can be read with single command.</p> <p>If no data present in receive buffer no data is copied.</p> <ol style="list-style-type: none"> 3. Update size of bytes read in input image bits 'RL0 to RL2' In case of no data present in RX buffer, size is updated as 0. 4. Status of RRBA in input image is updated indicating successful read operation. Status of RRB is copied to RRBA. 																																				
RES (Reserved)	BOOL	QWm (BYTE 0).3	--	Reserved.																																				
WL0...WL2 (Write Length bit 0 to Write Length bit 2)	BOOL	QWm (BYTE 0).4 to QWm (BYTE 0).6	--	<p>Write Length for Write Transmit Buffer command.</p> <p>Number of bytes to write to transmit buffer of module.</p> <table border="1"> <thead> <tr> <th>WL2</th> <th>WL1</th> <th>WL0</th> <th>Write Length (in Bytes)</th> </tr> </thead> <tbody> <tr> <td>0</td> <td>0</td> <td>0</td> <td>0</td> </tr> <tr> <td>0</td> <td>0</td> <td>1</td> <td>1</td> </tr> <tr> <td>0</td> <td>1</td> <td>0</td> <td>2</td> </tr> <tr> <td>0</td> <td>1</td> <td>1</td> <td>3</td> </tr> <tr> <td>1</td> <td>0</td> <td>0</td> <td>4</td> </tr> <tr> <td>1</td> <td>0</td> <td>1</td> <td>5</td> </tr> <tr> <td>1</td> <td>1</td> <td>0</td> <td>6</td> </tr> <tr> <td>1</td> <td>1</td> <td>1</td> <td>7</td> </tr> </tbody> </table> <p>Maximum length is 7 bytes .</p>	WL2	WL1	WL0	Write Length (in Bytes)	0	0	0	0	0	0	1	1	0	1	0	2	0	1	1	3	1	0	0	4	1	0	1	5	1	1	0	6	1	1	1	7
WL2	WL1	WL0	Write Length (in Bytes)																																					
0	0	0	0																																					
0	0	1	1																																					
0	1	0	2																																					
0	1	1	3																																					
1	0	0	4																																					
1	0	1	5																																					
1	1	0	6																																					
1	1	1	7																																					
TX (Transmit Data from Buffer)	BOOL	QWm (BYTE 0).7	Change of state [0 → 1 or 1 → 0]	<p>Transmit command.</p> <p>Fieldbus master can generate command to transmit data from transmit buffer of module using this bit.</p> <p>When module receives change of state of this bit, module does following</p> <ol style="list-style-type: none"> 1. Transmit all data available in transmit buffer over serial communication. 2. Once data transmission is complete, status of TXA in input image is updated indicating successful trasmission. Status of TX is copied to TXA. 																																				
WR Byte 1	BYTE	QWm (BYTE 1)	--	Write Data byte 1.																																				
WR Byte 2	BYTE	QWm+1 (BYTE 0)	--	Write Data byte 2.																																				
WR Byte 3	BYTE	QWm+1 (BYTE 1)	--	Write Data byte 3.																																				
WR Byte 4	BYTE	QWm+2 (BYTE 0)	--	Write Data byte 4																																				
WR Byte 5	BYTE	QWm+2 (BYTE 1)	--	Write Data byte 5.																																				
WR Byte 6	BYTE	QWm+3 (BYTE 0)	--	Write Data byte 6.																																				
WR Byte 7	BYTE	QWm+3 (BYTE 1)	--	Write Data byte 7.																																				

*Similarly, output data for CH1 is mapped from QWm+4 to QWm+7.

NOTE

When fieldbus master is in STOP mode then,

- Module goes in initialization mode.

When fieldbus master gets disconnected from network then,

- It is recommended to initialize channels using INIT command.

User can monitor the following diagnostics.

Channel	Data Type	Local Address	Bit Status	Comment
Module Diagnostics	BYTE	SB (n)	--	--
No field power supply	BOOL	SB (n).0	TRUE	24 VDC field power supply is not available.
			FALSE	24 VDC field power supply is available.
RBO0 (RX Buffer Overflow CH0)	BOOL	SB (n).1	TRUE	Receive buffer of CH0 is full. After CH0 receive buffer overflow, additional bytes received from external device are not acknowledged by module. Receive buffer size is 512 bytes per channel.
			FALSE	No transmit buffer overflow error.
PE0 (Parity Error CH0)	BOOL	SB (n).2	TRUE	Parity error occur during data reception on CH0. In case of parity error, received byte is not copied to receive buffer of module. Once set, parity error is reset after channel initialisation. (When initialisation command INIT is generated from fieldbus master or power cycle)
			FALSE	No Parity error
FE0 (Framing Error CH0)	BOOL	SB (n).3	TRUE	Framing error occur during data reception on CH0. In case of framing error, received byte is not copied to receive buffer of module. Once set, framing error is reset after channel initialisation. (When initialisation command INIT is generated from fieldbus master or power cycle)
			FALSE	No Framing error

RBO1 (RX Buffer Overflow CH1)	BOOL	SB (n).4	TRUE	Receive buffer of CH1 is full. After CH1 receive buffer overflow, additional bytes received from external device are not acknowledged by module. Receive buffer size is 512 bytes per channel.
			FALSE	No transmit buffer overflow error.
PE1 (Parity Error CH1)	BOOL	SB (n).5	TRUE	Parity error occur during data reception on CH1. In case of parity error, received byte is not copied to receive buffer of module. Once set, parity error is reset after channel initialisation. (When initialisation command INIT is generated from fieldbus master or power cycle)
			FALSE	No Parity error
FE1 (Framing Error CH1)	BOOL	SB (n).6	TRUE	Framing error occur during data reception on CH1. In case of framing error, received byte is not copied to receive buffer of module. Once set, framing error is reset after channel initialisation. (When initialisation command INIT is generated from fieldbus master or power cycle)
			FALSE	No Framing error

Module diagnostic data is available in Status Byte (SB) memory, if module parameter "Share diagnostics" is set to **Enable**.

Refer section [Troubleshooting](#) for station error code list and error messages

Transmit and Receive Example

Module provides buffer of 512 bytes for receive and 256 bytes for transmit.

Network master/controller can write to transmit buffer and read from receive buffer of module using IO data of 8 bytes. 1 byte IO data is for handshaking and 7 bytes of IO data for serial communication. So maximum 7 bytes of data can be exchanged with module in one iteration.

User should develop suitable logic using handshaking information in network master/ controller to write transmit frame to transmit buffer in chunk of 7 bytes and then transmit over serial communication. E.g. to write 32 bytes, it will take 5 iterations.

Similarly, user should develop suitable logic in network master controller to read from receive buffer in chunks of 7 bytes and combine these bytes together in sequence to form receive frame. Then, it can be processed as per protocol.

Refer following formula to determine typical time taken to transmit/ receive IO data.

$$\left[\left(\text{Roundup} (\text{No. Of Bytes} / 7) + 1 \right) \times 2 \times \text{Network cycle time} \right] + \text{Serial communication time}$$

Prerequisites:

Modular IO station is communicating with fieldbus master and IO data communication established.

External device is connected to M-1R2 device over serial communication.

Channel is initialised using INIT command from fieldbus master and channel is ready for serial communication.

Note:

To avoid malfunctioning of communication between M-1R2 module with external device take care in master application program to initialise communication channels in following cases.

- Recovery after disconnection of modular IO station over fieldbus.
- Any kind of error in reception like parity error, frame error, receive buffer overflow
- Reconnection of fieldbus.
- Reconnection of field power supply.

Transmit example: Consider an example where ASCII string 'MITSUBISHI' of 10 characters is transmitted to external device connected to M-2R2 module.

Step	Step Details	Output from Fieldbus Master	Input from Modular IO station (M-2R2)	M-2R2 TX buffer memory
1	Generate 'write transmit buffer' command from fieldbus master to write first 7 bytes to transmit buffer of M-2R2	Control Byte INIT =0, WTB =1, RRB =0, WL2 =1, WL1 =1, WL0 =1, Res =0, TX =0 WR Byte 0 ... WR Byte7 = 0x4D, 0x49, 0x54, 0x 53, 0x55, 0x42, 0x48	Status Byte INTA =0, WTBA =0, RRBA =0, RBO =0, RL2 =0, RL1=0, RL0 =0, TXA=0 RD Byte 0 ... RD Byte7 = 0x00, 0x00, 0x00, 0x00, 0x00, 0x00, 0x00	null
2	M-2R2 module acknowledges WTB command from master	Control Byte INIT =0, WTB =1, RRB =0, WL2 =1, WL1 =1, WL0 =1, Res =0, TX =0 WR Byte 0 ... WR Byte7 = 0x4D, 0x49, 0x54, 0x 53, 0x55, 0x42, 0x48	Status Byte INTA =0, WTBA =1, RRBA =0, RBO =0, RL2 =0, RL1=0, RL0 =0, TXA=0 RD Byte 0 ... RD Byte7 = 0x00, 0x00, 0x00, 0x00, 0x00, 0x00, 0x00	0x4D, 0x49, 0x54, 0x 53, 0x55, 0x42, 0x48
3	Generate 'write transmit buffer' command from fieldbus master to write remaining 3 bytes to transmit buffer of M-2R2	Control Byte INIT =0, WTB =0, RRB =0, WL2 =0, WL1 =1, WL0 =1, Res =0, TX =0 WR Byte 0 ... WR Byte7 = 0x53, 0x48, 0x49, 0x 00, 0x00, 0x00, 0x00	Status Byte INTA =0, WTBA =1, RRBA =0, RBO =0, RL2 =0, RL1=0, RL0 =0, TXA=0 RD Byte 0 ... RD Byte7 = 0x00, 0x00, 0x00, 0x00, 0x00, 0x00, 0x00	0x4D, 0x49, 0x54, 0x 53, 0x55, 0x42, 0x48
4	M-2R2 module acknowledges WTB command from master	Control Byte INIT =0, WTB =0, RRB =0, WL2 =0, WL1 =1, WL0 =1, Res =0, TX =0 WR Byte 0 ... WR Byte7 = 0x53, 0x48, 0x49, 0x 00, 0x00, 0x00, 0x00	Status Byte INTA =0, WTBA =0, RRBA =0, RBO =0, RL2 =0, RL1=0, RL0 =0, TXA=0 RD Byte 0 ... RD Byte7 = 0x00, 0x00, 0x00, 0x00, 0x00, 0x00, 0x00	0x4D, 0x49, 0x54, 0x 53, 0x55, 0x42, 0x48, 0x53, 0x48, 0x49
5	Generate 'Transmit (TX)' command from fieldbus master	Control Byte INIT =0, WTB =0, RRB =0, WL2 =0, WL1 =1, WL0 =1, Res =0, TX =1 WR Byte 0 ... WR Byte7 = 0x53, 0x48, 0x49, 0x 00, 0x00, 0x00, 0x00	Status Byte INTA =0, WTBA =0, RRBA =0, RBO =0, RL2 =0, RL1=0, RL0 =0, TXA=0 RD Byte 0 ... RD Byte7 = 0x00, 0x00, 0x00, 0x00, 0x00, 0x00, 0x00	0x4D, 0x49, 0x54, 0x 53, 0x55, 0x42, 0x48, 0x53, 0x48, 0x49
6	M-2R2 module transmit data over serial communication and acknowledges successful transmission.	Control Byte INIT =0, WTB =0, RRB =0, WL2 =0, WL1 =1, WL0 =1, Res =0, TX =1 WR Byte 0 ... WR Byte7 = 0x53, 0x48, 0x49, 0x 00, 0x00, 0x00, 0x00	Status Byte INTA =0, WTBA =0, RRBA =1, RBO =0, RL2 =0, RL1=0, RL0 =0, TXA=0 RD Byte 0 ... RD Byte7 = 0x00, 0x00, 0x00, 0x00, 0x00, 0x00, 0x00	null

Receive Example: Consider an example where ASCII string 'MITSUBISHI' of 10 characters is transmitted by external device to M-2R2 module and receive buffer data is read by fieldbus master.

Step	Step Details	Output from Fieldbus Master	Input from Modular IO station (M-2R2)	M-2R2 RX buffer memory
1	Fieldbus master generates 'Read Receive Buffer' command to read data from RX buffer.	Control Byte INIT =0, WTB =0, RRB =1, WL2 =0, WL1 =0, WL0 =0, Res =0, TX =0 WR Byte 0 ... WR Byte7 = 0x00, 0x00, 0x00, 0x00, 0x00, 0x00, 0x00, 0x00	Status Byte INTA =0, WTBA =0, RRBA =0, RBO =0, RL2 =0, RL1=0, RL0 =0, TXA=0 RD Byte 0 ... RD Byte7 = 0x00, 0x00, 0x00, 0x00, 0x00, 0x00, 0x00, 0x00	null
2	Since no data is available in RX buffer module acknowledges RRB command by RRBA and read length =0 bytes.	Control Byte INIT =0, WTB =0, RRB =1, WL2 =0, WL1 =0, WL0 =0, Res =0, TX =0 WR Byte 0 ... WR Byte7 = 0x00, 0x00, 0x00, 0x00, 0x00, 0x00, 0x00, 0x00	Status Byte INTA =0, WTBA =0, RRBA =1, RBO =0, RL2 =0, RL1=0, RL0 =0, TXA=0 RD Byte 0 ... RD Byte7 = 0x00, 0x00, 0x00, 0x00, 0x00, 0x00, 0x00, 0x00	null
3	M-2R2 module receives 10 bytes data over serial communication	--	--	0x4D, 0x49, 0x54, 0x 53, 0x55, 0x42, 0x48, 0x53, 0x48, 0x49
4	Fieldbus master generates 'Read Receive Buffer' command to read data from RX buffer.	Control Byte INIT =0, WTB =0, RRB =0, WL2 =0, WL1 =0, WL0 =0, Res =0, TX =0 WR Byte 0 ... WR Byte7 = 0x00, 0x00, 0x00, 0x00, 0x00, 0x00, 0x00, 0x00	Status Byte INTA =0, WTBA =0, RRBA =1, RBO =0, RL2 =0, RL1=0, RL0 =0, TXA=0 RD Byte 0 ... RD Byte7 = 0x00, 0x00, 0x00, 0x00, 0x00, 0x00, 0x00, 0x00	0x4D, 0x49, 0x54, 0x 53, 0x55, 0x42, 0x48, 0x53, 0x48, 0x49

5	M-2R2 module acknowledges WTB command from master and copies 7 bytes from RX buffer data to input image. Receive length is 7 bytes.	Control Byte INIT =0, WTB =0, RRB =0, WL2 =0, WL1 =0, WL0 =0, Res =0, TX =0 WR Byte 0 ... WR Byte7 = 0x00, 0x00, 0x00, 0x00, 0x00, 0x00, 0x00	Status Byte INTA =0, WTBA =0, RRBA =0, RBO =0, RL2 =1, RL1=1, RL0 =1, TXA=0 RD Byte 0 ... RD Byte7 = 0x4D, 0x49, 0x54, 0x 53, 0x55, 0x42, 0x48	0x53, 0x48, 0x49
6	Fieldbus master generates 'Read Receive Buffer' command to read data from RX buffer.	Control Byte INIT =0, WTB =0, RRB =1, WL2 =0, WL1 =0, WL0 =0, Res =0, TX =0 WR Byte 0 ... WR Byte7 = 0x00, 0x00, 0x00, 0x00, 0x00, 0x00, 0x00	Status Byte INTA =0, WTBA =0, RRBA =0, RBO =0, RL2 =1, RL1=1, RL0 =1, TXA=0 RD Byte 0 ... RD Byte7 = 0x4D, 0x49, 0x54, 0x 53, 0x55, 0x42, 0x48	0x53, 0x48, 0x49
7	M-2R2 module acknowledges WTB command from master and copies remaining 3 bytes from RX buffer data to input image. Receive length is 3 bytes.	Control Byte INIT =0, WTB =0, RRB =1, WL2 =0, WL1 =0, WL0 =0, Res =0, TX =0 WR Byte 0 ... WR Byte7 = 0x00, 0x00, 0x00, 0x00, 0x00, 0x00, 0x00	Status Byte INTA =0, WTBA =0, RRBA =1, RBO =0, RL2 =0, RL1=1, RL0 =1, TXA=0 RD Byte 0 ... RD Byte7 = 0x53, 0x48, 0x49, 0x00, 0x00, 0x00, 0x00	null
8	Fieldbus master generates 'Read Receive Buffer' command to read data from RX buffer.	Control Byte INIT =0, WTB =0, RRB =0, WL2 =0, WL1 =0, WL0 =0, Res =0, TX =0 WR Byte 0 ... WR Byte7 = 0x00, 0x00, 0x00, 0x00, 0x00, 0x00, 0x00	Status Byte INTA =0, WTBA =0, RRBA =1, RBO =0, RL2 =0, RL1=1, RL0 =1, TXA=0 RD Byte 0 ... RD Byte7 = 0x53, 0x48, 0x49, 0x00, 0x00, 0x00, 0x00	null
9	Since no data is available in RX buffer module acknowledges RRB command by RRBA and read length =0 bytes.	Control Byte INIT =0, WTB =0, RRB =0, WL2 =0, WL1 =0, WL0 =0, Res =0, TX =0 WR Byte 0 ... WR Byte7 = 0x00, 0x00, 0x00, 0x00, 0x00, 0x00, 0x00	Status Byte INTA =0, WTBA =0, RRBA =0, RBO =0, RL2 =0, RL1=0, RL0 =0, TXA=0 RD Byte 0 ... RD Byte7 = 0x00, 0x00, 0x00, 0x00, 0x00, 0x00, 0x00	null

ASCII Codes M=0x4D, I = 0x49, T =0x54, S=0x 53, U=0x 55, B=0x42, S=0x 53, H=0x48, I=0x49.

9.2 M-1R2

[1 Ch. Serial COM (RS232) Module]

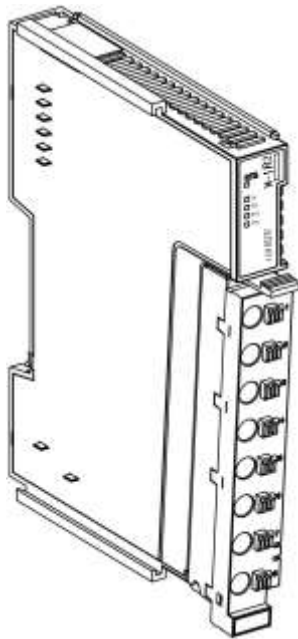

[Module Overview](#)

[Part Names](#)

[Specifications](#)

[LED Indications](#)

[Connection Diagram](#)

[Parameters](#)

[IO Data](#)

Module Overview

M-1R2 is 1 channel serial communication module. It provides RS232 full duplex serial communication channel with RTS/CTS flow control. The module can be fixed in any IO slot of modular IO station.

Considering methodology of serial communication over fieldbus network, handling simple protocols like ASCII protocol will be easier from application program perspective. It is recommended to interface serial devices like bar code scanner, RFIDs, printers, etc. Refer section [Transmit and receive example](#) which provides more information of IO data with example.

Fieldbus network cycle time is a major factor to decide effective throughput of module. Typically, 100 bytes can be transmitted / received at an interval of 600 msec at baud rate of 9600bps and network cycle time of 10 msec.

Part Names

The figure below describes part names of the module.

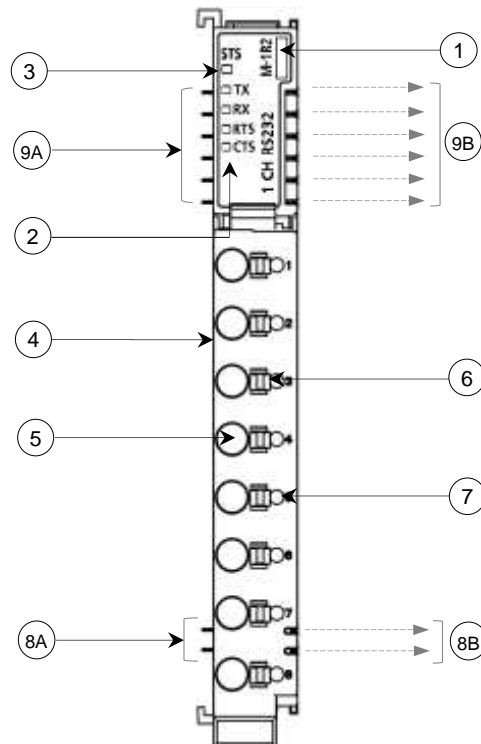

No.	Name	Description
1	M-1R2	Module ordering code
2	Channel LED Indications	TX, RX: Transmit/ Receive signal lines RTS, CTS: Flow control signal lines
3	Module Status LED Indication	STS: 1 Bi-colour LED for module status
4	Terminal Block	8-point removable push type
5	IO Point	Wire insertion point
6	Push Button	Press to release wire
7	Test Point	To measure signal voltage
8A	Field Power Supply Interface	2 Incoming pins for field power supply interface
8B		2 Outgoing pins for field power supply interface
9A	System Power Supply Interface	6 Incoming pins for system power supply interface
9B		6 Outgoing pins for system power supply interface

Specifications

The table below provides technical specifications of **M-1R2**.

Specification		Description
Ordering Code		M-1R2
Hardware Interface		RS232 with RTS CTS flow control
Communication Type		Full duplex
Number of channels		1
Supported baud rate (in bps)		2400,4800,9600 [Default],19200,38400, 57600,115200
Receive Buffer size		512 bytes
Transmit Buffer Size		256 bytes
Input Image Size		8 bytes
Output Image Size		8 bytes
Length of Cable		15 meters maximum
LED Indications		1 bicolor LED (red + green) for, module status Indication. 4 LEDs (green) for channel indication, TX, RX : Transmit/ Receive signal lines RTS, CTS* : Flow control signal lines
High Signal Voltage		+18 VDC to +3 VDC
Low Signal Voltage		-18 VDC to -3 VDC
Maximum Signal Voltage		±40 VDC
Backplane Current Consumption		50 mA
Field Power Supply Consumption		40 mA
Terminal Block (Removable push type)		8 point
Isolation		Between communication port and internal circuit Optical 2.5 KV RMS
IO memory consumption	Input Bytes (IW)	8 bytes
	Output Bytes (QW)	8 bytes
	Diagnostic (SB) [User configurable]	1 byte
I/O terminals		TX, RX, RTS, CTS, GND, SHLD

*RTS is abbreviation of "Request To Send" and CTS is abbreviation of "Clear To Send".

NOTE

RTS signal (when hardware flow control is enabled) becomes low, when size of data in receive buffer is more than 80% (409 bytes) of receive buffer size (512 bytes).

It becomes high again, when size of data in receive buffer is less than 30% (153 bytes) of receive buffer size.

With RTS signal as low, module continues to receive data till receive buffer is full.

Module M-1R2 is supported in Modular IO Configurator Tool [V1.5.0.0] and Header (M-CCB-H and M-MT-H) firmware [V01.02.00.00], Header (M-EIP-H) firmware [V01.01.00.00] and onwards.

LED Indications

This section provides meaning of LED indications available on module.

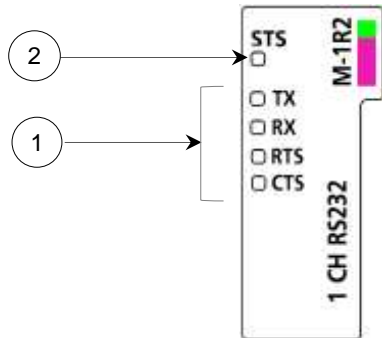

No.	*LED	Colour	Status	Description	
1	TX	Green	ON	TX Signal is high.	
			OFF	TX Signal is low.	
	RX		ON	RX Signal is high.	
			OFF	RX Signal is low.	
	RTS		ON	RTS Signal is high, <ul style="list-style-type: none"> Until size of data in receive buffer less than 80% (409 bytes) of receive buffer size (512 bytes). When size of data in receive buffer becomes less than 30% (153 bytes) of its receive buffer size. There is no parity error or framing error occurred during data reception. 	
			OFF	RTS Signal is low, <ul style="list-style-type: none"> When size of received data is greater than 80% (409 bytes) of receive buffer size and remains low, till size of received data is greater than 30% (153 bytes). Either parity error or framing error occurred during data reception. 	
	CTS		ON	If CTS Signal is high, module can transmit data.	
			OFF	If CTS Signal is low, module stops transmitting data.	
2	STS	Bi-colour LED	None	Module is powered OFF.	
			Blue Green	ON	Module is powered ON and communicating with Header module
				Single flash	Communication with Header is not established due to, <ul style="list-style-type: none"> Module is powered ON and waiting for communication from Header. Module mismatch
			Red	ON	Hardware failure is detected on module.
				Single flash	One of the following conditions occurred. <ul style="list-style-type: none"> No communication from Header Backplane bus fault detected.
				Double flash	<ul style="list-style-type: none"> Parity Error occurred at reception. Framing Error occurred at reception. Overrun Error occurred at reception.
			Yellow	ON	24 VDC field power supply is not available

*For more details of LED indication states and flashing rates, refer section [Troubleshooting >> LED indications: States and flashing rates](#) in this manual.

Waveforms: Flow control signals

This section explains behavior of RTS signal.

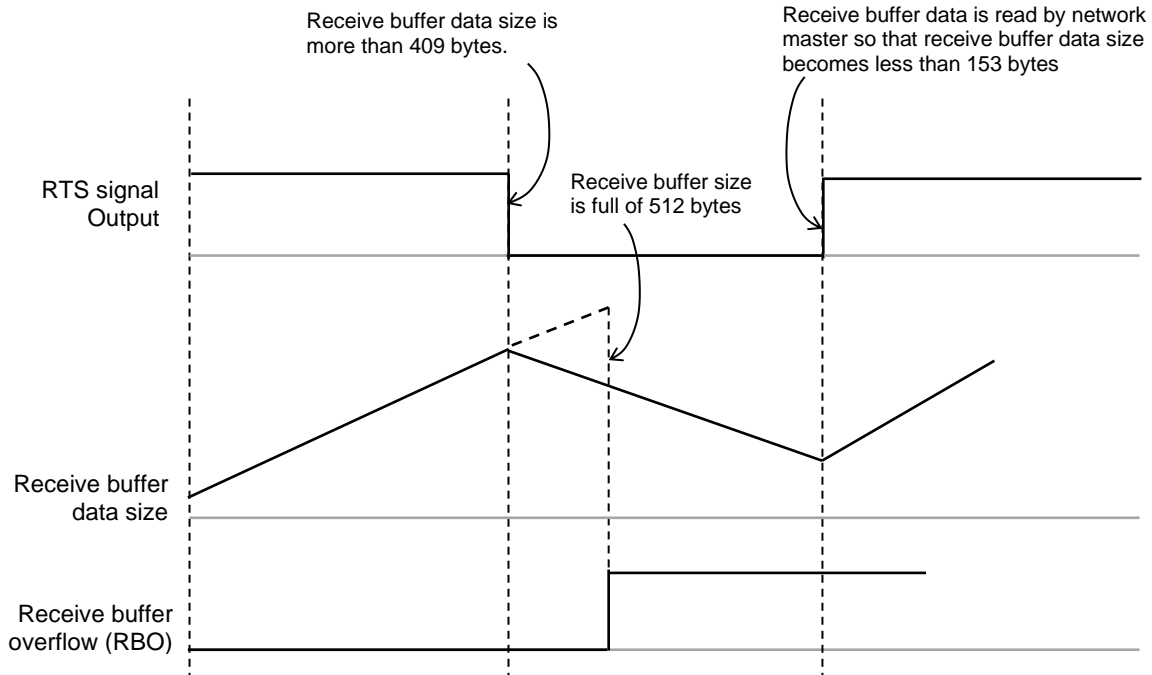

The figure below explains behaviour of CTS signal.

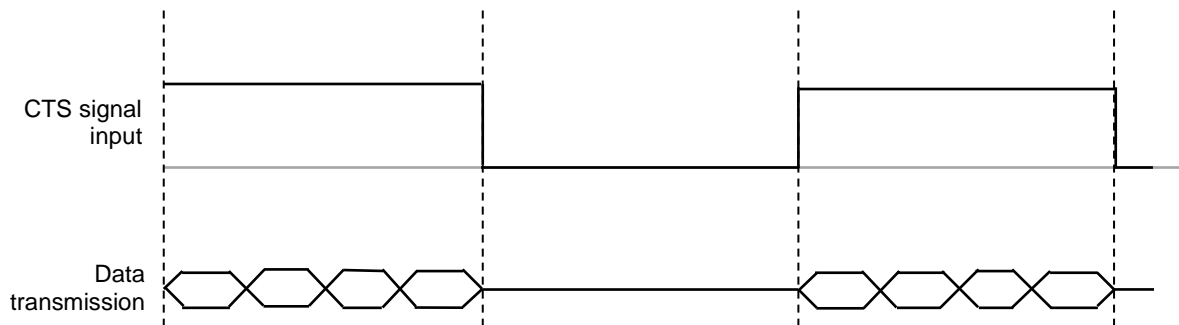

Connection Diagram

The figure shows module front with 8 points terminal block, to interface serial communication module and external devices, to establish communication.

Wiring description is provided on right side wall of the module.

The figures below show connections for channel 0, for example.

For common wiring recommendations, refer section [Wiring](#).

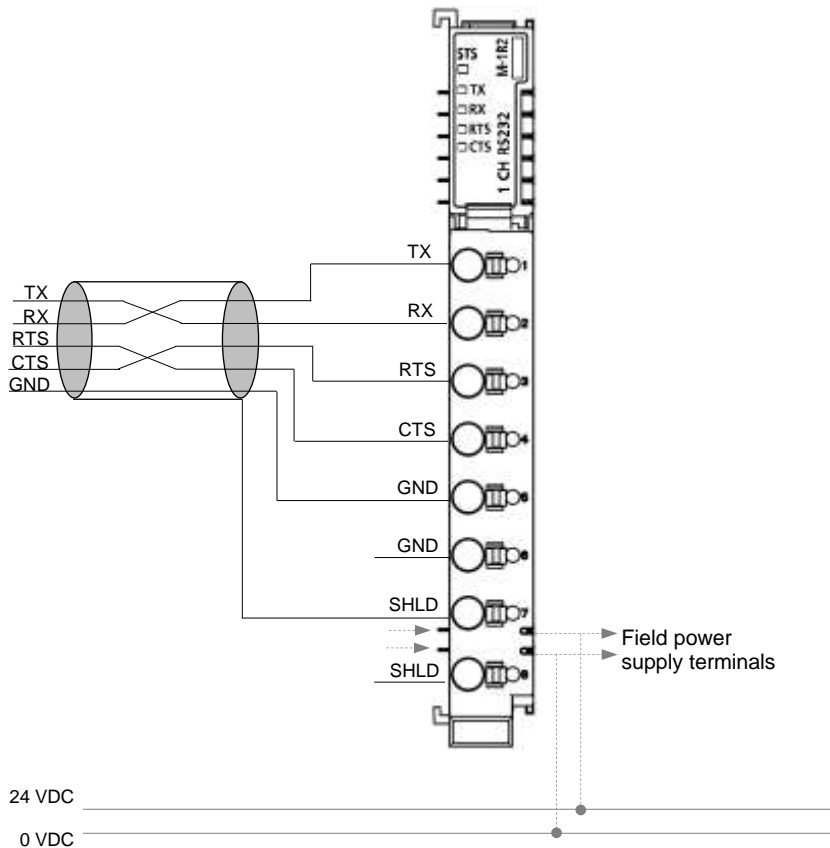

M-1R2: Wiring description

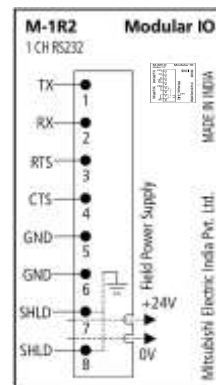

NOTE

Recommended length of RS232 serial communication cable is maximum up to 15 meters.

Parameters

Module can be configured using Modular IO Configurator.

For addition and removal of module in configuration tool, refer section [Modular IO Configurator](#).

User can set following parameters.

Parameter Name	Project Value	Comment
Share diagnostics	Enable [Default]	Enables diagnostic data (SB) sharing with header
	Disable	

Module diagnostic data and channel diagnostic data is available in Status Byte (SB) memory, if module parameter "Share diagnostics" is set to Enable.

The table below provides a list of channel parameters that user can set as per application requirement.

Parameter Name	Project Value	Comment
Enable	Yes [Default] No	Enable/ disable channel
Baud rate	2400 4800 9600 [Default] 19200 38400 57600 115200	Communication baud rate
Parity	None Odd [Default] Even	Parity selection
No. of data bits	7 bits 8 bits [Default] 9 bits	Number of data bits
No. of stop bits	1 bit [Default] 2 bits	Number of stop bits
Flow control	No flow control [Default] Hardware flow control	Hardware flow control or No flow control

For more functional details, refer [Transmit and Receive Example](#) provided in this manual.

IO Data

Following table provides description for input data and output data.

Channel	Data Type	Local Address*
CH0	BYTE	IW n (BYTE 0)
	BYTE	QW m (BYTE 0)

*Local address (n) and (m) values changes as per the slot position of IO module and configuration of modular IO station.

For serial communication module,

IW memory holds status information and received data as shown below.

	IWn.7	IWn.6	IWn.5	IWn.4	IWn.3	IWn.2	IWn.1	IWn.0
IWn Byte 0	TXA	RL2	RL1	RL0	TBO	RRBA	WTBA	INITA
IWn Byte 1	Read byte 1							
IWn+1 Byte 0	Read byte 2							
IWn+1 Byte 1	Read byte 3							
IWn+2 Byte 0	Read byte 4							
IWn+2 Byte 1	Read byte 5							
IWn+3 Byte 0	Read byte 6							
IWn+3 Byte 1	Read byte 7							

Channel	Data Type	Local Address	Status	Comment
Input Data CH0*				
INITA (Init Ack)	BOOL	IWn (BYTE 0).0	TRUE	Initialisation Acknowledge. Module sends acknowledgement of INIT command received from fieldbus master using this bit.
			FALSE	Channel is ready for serial communication.
WTBA (Write TX Buffer Ack)	BOOL	IWn (BYTE 0).1	Change of state [0 → 1 or 1 → 0]	Write Transmit Buffer Acknowledge. Module sends acknowledgement of WTB command received from fieldbus master using this bit. Status of WTB is copied to WTBA, after successful writing to transmit buffer of module.
RRBA (Read RX Buffer Ack)	BOOL	IWn (BYTE 0).2		Read Receive Buffer Acknowledge. Module sends acknowledgement of RRB command received from fieldbus master using this bit. Status of RRB is copied to RRBA after successful reading from receive buffer of module.
TBO (TX Buffer Overflow)	BOOL	IWn (BYTE 0).3		Transmit Buffer Overflow. Transmit buffer of module is full. After transmit buffer overflow, additional bytes received on serial communication are lost. Transmit buffer size is 256 bytes per channel.

RL0.....RL2 (Receive Length bit 0 to Receive Length bit 2)	BOOL	IWn (BYTE 0).4 to IWn (BYTE 0).6	--	<p>Read Length for Read Receive Buffer command Number of bytes read from receive buffer of module.</p> <table border="1"> <thead> <tr> <th>RL2</th> <th>RL1</th> <th>RL0</th> <th>Read Length (in Bytes)</th> </tr> </thead> <tbody> <tr> <td>0</td> <td>0</td> <td>0</td> <td>0</td> </tr> <tr> <td>0</td> <td>0</td> <td>1</td> <td>1</td> </tr> <tr> <td>0</td> <td>1</td> <td>0</td> <td>2</td> </tr> <tr> <td>0</td> <td>1</td> <td>1</td> <td>3</td> </tr> <tr> <td>1</td> <td>0</td> <td>0</td> <td>4</td> </tr> <tr> <td>1</td> <td>0</td> <td>1</td> <td>5</td> </tr> <tr> <td>1</td> <td>1</td> <td>0</td> <td>6</td> </tr> <tr> <td>1</td> <td>1</td> <td>1</td> <td>7</td> </tr> </tbody> </table> <p>Maximum length is 7 bytes.</p>	RL2	RL1	RL0	Read Length (in Bytes)	0	0	0	0	0	0	1	1	0	1	0	2	0	1	1	3	1	0	0	4	1	0	1	5	1	1	0	6	1	1	1	7
RL2	RL1	RL0	Read Length (in Bytes)																																					
0	0	0	0																																					
0	0	1	1																																					
0	1	0	2																																					
0	1	1	3																																					
1	0	0	4																																					
1	0	1	5																																					
1	1	0	6																																					
1	1	1	7																																					
TXA (Transmit Ack)	BOOL	IWn (BYTE 0).7	Change of state [0 → 1 or 1 → 0]	<p>Transmit Acknowledge. Module sends acknowledgement of TX command received from fieldbus master using this bit. Once data transmission is complete, status of TX is copied to TXA.</p>																																				
RD Byte 1	BYTE	IWn (BYTE 1)	--	Read Data byte 1.																																				
RD Byte 2	BYTE	IWn+1 (BYTE 0)	--	Read Data byte 2.																																				
RD Byte 3	BYTE	IWn+1 (BYTE 1)	--	Read Data byte 3.																																				
RD Byte 4	BYTE	IWn+2 (BYTE 0)	--	Read Data byte 4.																																				
RD Byte 5	BYTE	IWn+2 (BYTE 1)	--	Read Data byte 5																																				
RD Byte 6	BYTE	IWn+3 (BYTE 0)	--	Read Data byte 6.																																				
RD Byte 7	BYTE	IWn+3 (BYTE 1)	--	Read Data byte 7.																																				

QW memory holds control information and transmit data as shown below.

	QWm.7	QWm.6	QWm.5	QWm.4	QWm.3	QWm.2	QWm.1	QWm.0
QWm Byte 0	TX	WL2	WL1	WL0	RES	RRB	WTB	INIT
QWm Byte 1	Write byte 1							
QWm+1 Byte 0	Write byte 2							
QWm+1 Byte 1	Write byte 3							
QWm+2 Byte 0	Write byte 4							
QWm+2 Byte 1	Write byte 5							
QWm+3 Byte 0	Write byte 6							
QWm+3 Byte 1	Write byte 7							

Channel	Data Type	Local Address	Status	Comment
Output Data CH0*				
INIT (Init)	BOOL	QWm (BYTE 0).0	TRUE	<p>Initialisation command.</p> <p>Fieldbus master can generate request to reset channel using this bit.</p> <p>When this bit is ON, channel is initialised.</p> <p>When initialised, module takes following actions,</p> <ol style="list-style-type: none"> 1. FIFO pointers of TX buffer and RX buffer are initialised 2. Channel port is initialised with communication parameters set. 3. Errors are cleared. (Overrun, parity, framing) 4. Acknowledge status bits in input image are cleared.(WTBA, RRBA) 5. Status of INITA in input image is turned ON indicating successful initialisation.
			FALSE	No initialisation request is issued. Channel is ready for serial communication.
WTB (Write TX Buffer)	BOOL	QWm (BYTE 0).1	Change of state [0 → 1 or 1 → 0]	<p>Write Transmit Buffer command.</p> <p>Fieldbus master can generate command to write data to transmit buffer of module using this bit.</p> <p>When module receives change of state of this bit, module does following actions,</p> <ol style="list-style-type: none"> 1. Check size of data to write to transmit buffer in 'WL0 to WL2' 2. Write data received in 'WR Byte 1'to WR Byte 7' to transmit buffer of module as per write length. If write length is 0, then no data is written to transmit buffer. <p>Maximum 7 bytes data can be written with single command.</p> <ol style="list-style-type: none"> 3. Status of WTBA in input image is updated indicating successful write operation. Status of WTB is copied to WTBA.

RRB (Receive RX Buffer)	BOOL	QWm (BYTE 0).2		<p>Read Receive Buffer command.</p> <p>Fieldbus master can generate command to read data from receive buffer of module using this bit. When module receives state change on this bit, module does following actions,</p> <ol style="list-style-type: none"> 1. Checks if any data is present in its RX buffer. 2. If data is present in receive buffer, copy data from RX buffer to input image 'RD Byte 1' to 'RD Byte 7'. Data is copied on FIFO basis. <p>Maximum 7 bytes data can be read with single command.</p> <p>If no data present in receive buffer no data is copied.</p> <ol style="list-style-type: none"> 3. Update size of bytes read in input image bits 'RL0 to RL2' In case of no data present in RX buffer, size is updated as 0. 4. Status of RRBA in input image is updated indicating successful read operation. Status of RRB is copied to RRBA. 																																				
RES	BOOL	QWm (BYTE 0).3	--	Reserved.																																				
WL0....WL2 (Write Length bit 0 to Write Length bit 2)	BOOL	QWm (BYTE 0).4 to QWm (BYTE 0).6	--	<p>Write Length for Write Transmit Buffer command. Number of bytes to write to transmit buffer of module.</p> <p>Maximum length is 7 bytes.</p> <table border="1"> <thead> <tr> <th>WL2</th> <th>WL1</th> <th>WL0</th> <th>Write Length (in Bytes)</th> </tr> </thead> <tbody> <tr> <td>0</td> <td>0</td> <td>0</td> <td>0</td> </tr> <tr> <td>0</td> <td>0</td> <td>1</td> <td>1</td> </tr> <tr> <td>0</td> <td>1</td> <td>0</td> <td>2</td> </tr> <tr> <td>0</td> <td>1</td> <td>1</td> <td>3</td> </tr> <tr> <td>1</td> <td>0</td> <td>0</td> <td>4</td> </tr> <tr> <td>1</td> <td>0</td> <td>1</td> <td>5</td> </tr> <tr> <td>1</td> <td>1</td> <td>0</td> <td>6</td> </tr> <tr> <td>1</td> <td>1</td> <td>1</td> <td>7</td> </tr> </tbody> </table>	WL2	WL1	WL0	Write Length (in Bytes)	0	0	0	0	0	0	1	1	0	1	0	2	0	1	1	3	1	0	0	4	1	0	1	5	1	1	0	6	1	1	1	7
WL2	WL1	WL0	Write Length (in Bytes)																																					
0	0	0	0																																					
0	0	1	1																																					
0	1	0	2																																					
0	1	1	3																																					
1	0	0	4																																					
1	0	1	5																																					
1	1	0	6																																					
1	1	1	7																																					
TX (Transmit Data from Buffer)	BOOL	QWm (BYTE 0).7	Change of state [0 → 1 or 1 → 0]	<p>Transmit command.</p> <p>Fieldbus master can generate command to transmit data from transmit buffer of module using this bit.</p> <p>When module receives change of state of this bit, module does following</p> <ol style="list-style-type: none"> 1. Transmit all data available in transmit buffer over serial communication. 2. Once data transmission is complete, status of TXA in input image is updated indicating successful transmission. Status of TX is copied to TXA. 																																				
WR Byte 1	BYTE	QWm (BYTE 1)	--	Write Data byte 1.																																				
WR Byte 2	BYTE	QWm+1 (BYTE 0)	--	Write Data byte 2.																																				
WR Byte 3	BYTE	QWm+1 (BYTE 1)	--	Write Data byte 3.																																				
WR Byte 4	BYTE	QWm+2 (BYTE 0)	--	Write Data byte 4																																				
WR Byte 5	BYTE	QWm+2 (BYTE 1)	--	Write Data byte 5.																																				
WR Byte 6	BYTE	QWm+3 (BYTE 0)	--	Write Data byte 6.																																				
WR Byte 7	BYTE	QWm+3 (BYTE 1)	--	Write Data byte 7.																																				

NOTE

When fieldbus master is in STOP mode then,
 - Module goes in initialization mode.

When fieldbus master gets connected again after disconnection from network then,
 - It is recommended to initialize channels using INIT command.

User can monitor the following diagnostics.

Channel	Data Type	* Local Address	Bit Status	Comment
Module Diagnostics	BYTE	SB (n)	--	--
No field power supply	BOOL	SB (n).0	TRUE	24 VDC field power supply is not available.
			FALSE	24 VDC field power supply is available.
RBO0 (RX Buffer Overflow CH0)	BOOL	SB (n).1	TRUE	Receive buffer of CH0 is full. If RTS CTS flow control is Enable and after CH0 receive buffer overflow, additional bytes received from external device are not acknowledged by module. Receive buffer size is 512 bytes per channel.
			FALSE	No transmit buffer overflow error.
PE0 (Parity Error CH0)	BOOL	SB (n).2	TRUE	Parity error occur during data reception on CH0. In case of parity error, received byte is not copied to receive buffer of module. Once set, parity error is reset after channel initialisation. (When initialisation command INIT is generated from fieldbus master or power cycle)
			FALSE	No Parity error
FE0 (Framing Error CH0)	BOOL	SB (n).3	TRUE	Framing error occur during data reception on CH0. In case of framing error, received byte is not copied to receive buffer of module. Once set, framing error is reset after channel initialisation. (When initialisation command INIT is generated from fieldbus master or power cycle)
			FALSE	No Framing error

*Local address (n) changes as per the slot position of IO module and configuration of modular IO station.

Module diagnostic data is available in Status Byte (SB) memory if module parameter "Share diagnostics" is set to Enable.

Refer section [Troubleshooting](#) for station error code list and error messages.

For more functional details, refer [Transmit and Receive Example](#) provided in this manual.

9.3 M-1R4

[1 Ch. Serial COM (RS422/ RS485) Module]

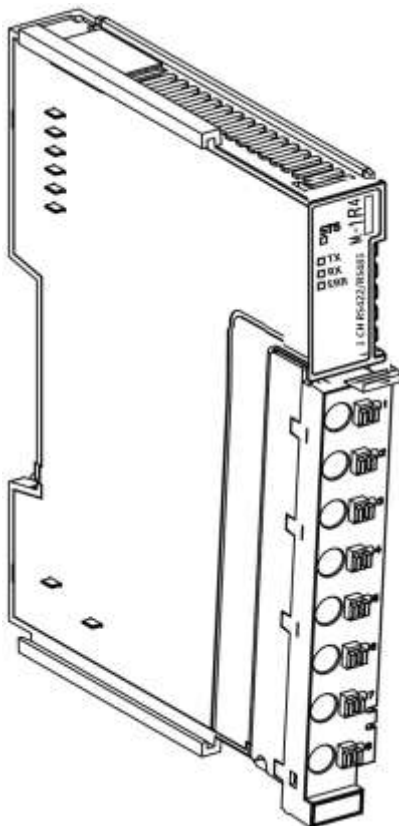

[Module Overview](#)

[Part Names](#)

[Specifications](#)

[LED Indications](#)

[Connection Diagram](#)

[Parameters](#)

[Operation mode - Extended Modbus RTU
Master](#)

Module Overview

M-1R4 is a 1 channel serial communication module. It provides RS422/485 serial communication channel. The module can be fixed in any IO slot of modular IO station.

User can configure up to two M-1R4 modules in any IO slot of a modular IO station.

In 'Extended Modbus RTU Master' operation mode, M-1R4 module functions as built in Modbus RTU master. Up to 16 Modbus RTU slave devices can be connected to the channel. In this mode, module function as communication gateway to exchange data between header module and Modbus RTU slave devices.

Module can exchange up to 250 words read and 250 words write data with slave devices.

NOTE

Note that number of M-1R4 modules in a modular IO station and size of read data and write data exchanged with slave devices is limited by following factors,

- The maximum size of IO data supported by header module.
- The IO memory size available for M-1R4 module, which is affected by IO memory consumed by other modules configured prior to the M-1R4 module in modular IO station configuration.
- Size of IO data consumed by the M-1R4 module itself.

Following diagram shows typical system configuration with M-1R4 module in 'Extended Modbus' mode.

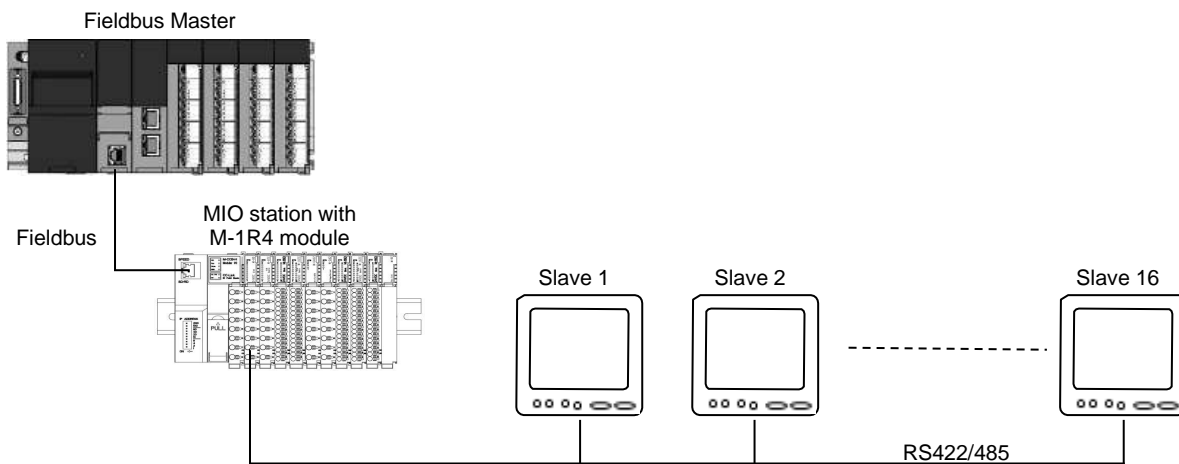

NOTE

To use M-1R4 module, ensure following,

- Modular IO Configurator Tool version V1.12.0.0 or higher
- Header M-CCIEF-H module version V1.0.0.0 or higher

Part Names

The figure below describes part names of the module.

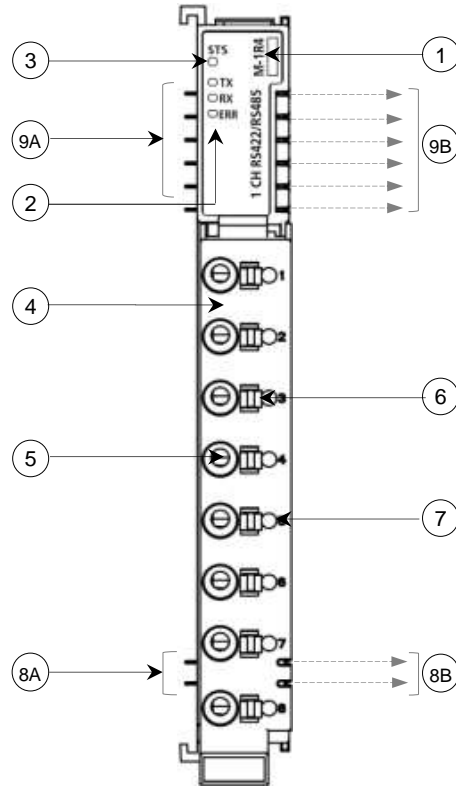

No.	Name	Description
1	M-1R4	Module ordering code
2	Channel LED Indications	TX, RX: Transmit/ Receive signal status. ERR: Error indication while communicating with one or more Modbus slave devices.
3	Module Status LED Indication	STS: 1 Bi-colour LED for module status
4	Terminal Block	8-point removable push type
5	IO Point	Wire insertion point
6	Push Button	Press to release wire
7	Test Point	To measure signal voltage
8A	Field Power Supply Interface	2 Incoming pins for field power supply interface
8B		2 Outgoing pins for field power supply interface
9A	System Power Supply Interface	6 Incoming pins for system power supply interface
9B		6 Outgoing pins for system power supply interface

Specifications

The table below provides technical specifications of **M-1R4**.

Specification		Description	
Ordering Code		M-1R4	
Number of Channels		1	
Number of Modules in a Modular IO station		2 maximum	
Supported Header Modules		M-CCIEF-H [CC Link IE Field Header Module]	
Transmission Standards		Conforms to RS-485/ RS-422 specifications	
Communication Type		Full duplex / Half duplex	
Length of Cable		1200 meters maximum	
Number of Slave Devices		16 maximum	
Supported Communication Parameters		Data transmission speed	2400,4800,9600 [Default],19200,38400,57600,115200
		Data bits	7, 8 [Default]
		Parity	Odd [Default], Even, None
		Stop bits	1 [Default], 2
Operation Modes		Extended Modbus RTU Master mode	
Receive Buffer Size		512 Bytes	
Transmit Buffer Size		512 Bytes	
IO data updation time		500 ms minimum (up to header)	
LED Indications		STS, RX, TX, ERR (Refer section ' LED Indications ' for more details)	
Maximum Signal Voltage		± 12VDC	
System Power Supply Consumption		50 mA	
Field Power Supply Consumption		40 mA	
Terminal Block (Removable push type)		8 points	
Isolation		Between communication port and internal circuit	2500 V AC
		Between communication port and field power supply	2500 V AC
Protection		Short circuit protection for output signal	
IO Memory Consumption	Input Bytes (IW)	10 bytes + Read data size (configurable up 500 bytes)	
	Output Bytes (QW)	6 bytes + Write data size (configurable up 500 bytes)	
	Diagnostic (SB)	4 bytes (User configurable)	
I/O Terminals		TXD+, TXD-, RXD+, RXD-, GND, SHLD, TER	
Recommended wire specifications		Shielded twisted pair cable	
Module Dimensions (H x W x D) in mm		105 x 13.2 x 83	

LED Indications

This section provides meaning of LED indications available on module.

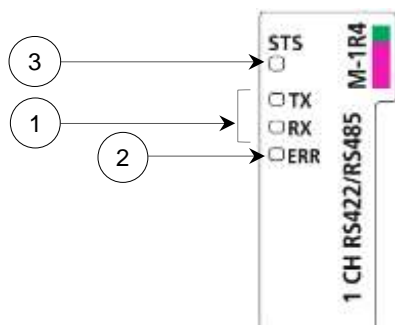

No.	*LED	Color	Status		Description
1	TX	Green	ON/ Flashing		Data being transmitted
			OFF		Data not transmitted
	RX		ON/ Flashing		Data being received
			OFF		Data not received
2	ERR	Red	OFF		No Modbus communication error
			Single Flash		Error observed while communicating with one or more Modbus slave devices.
			Double Flash		Occurrence of one of the following error <ul style="list-style-type: none"> - Parity Error - Framing Error - Overrun Error Once error is detected, indication will continue till user resets communication using control bit 'RST' or clear error using control bit 'RST_ERR'.
3	STS	Bi-colour LED	None	OFF	Module is powered OFF
			Blue Green	ON	Module is powered ON and communicating with Header module
				Single Flash	Communication with Header is not established due to, <ul style="list-style-type: none"> - Module is powered ON and waiting for communication from Header. - Module mismatch
			Red	ON	Hardware failure is detected on module.
				Single flash	One of the following conditions occurred. <ul style="list-style-type: none"> - No communication from Header - Backplane bus fault detected.
			Yellow	ON	24 VDC field power supply is not available

*For more details of LED indication states and flashing rates, refer section [Troubleshooting >> LED indications: States and flashing rates](#) in this manual.

Connection Diagram

The figure shows module front with 8 points terminal block, connecting the M-1R4 module to external devices for communication.

Wiring description is provided on right side wall of the module.

The figure below shows connections.

For common wiring recommendations, refer section Wiring.

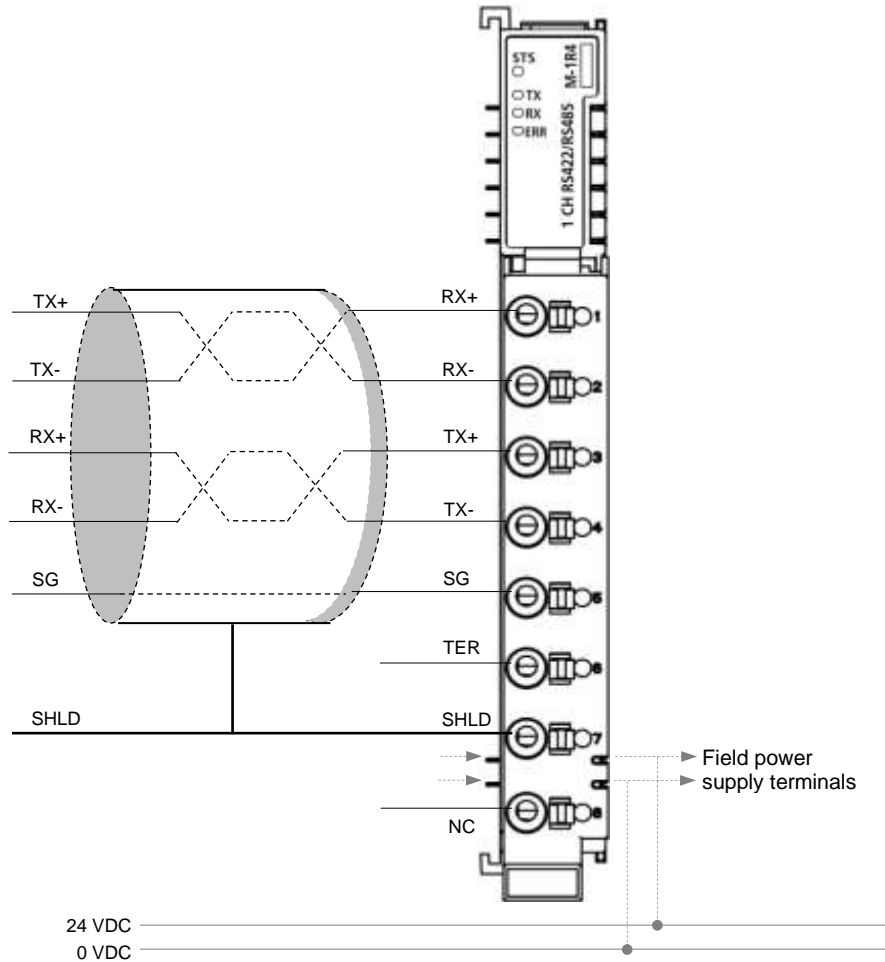

M-1R4: Wiring description.

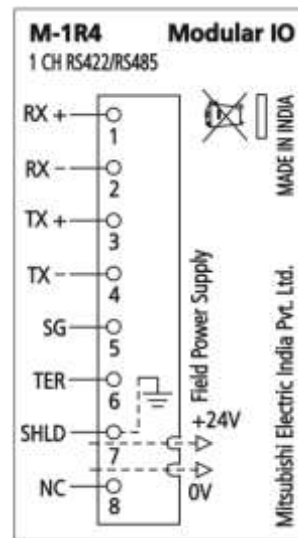

NOTE

- Do not bundle communication cable with main circuit and the power cables, and do not install them close to each other. Keep a distance of 100 mm or more between them. Failure to do so may result in malfunction due to noise.
- Be sure the shield is single point grounded.
- Connect a terminating resistor as shown in the connection examples, Connect external '330 Ω 1/4W' terminating resistor for RS-422 communication. Connect '120 Ω 1/2W' terminating resistor for RS-485 communication.
- At the M-1R4 module end, you can connect termination of 120 Ω by short-circuiting terminals TX-/RX- with TER.

Connection example RS-422

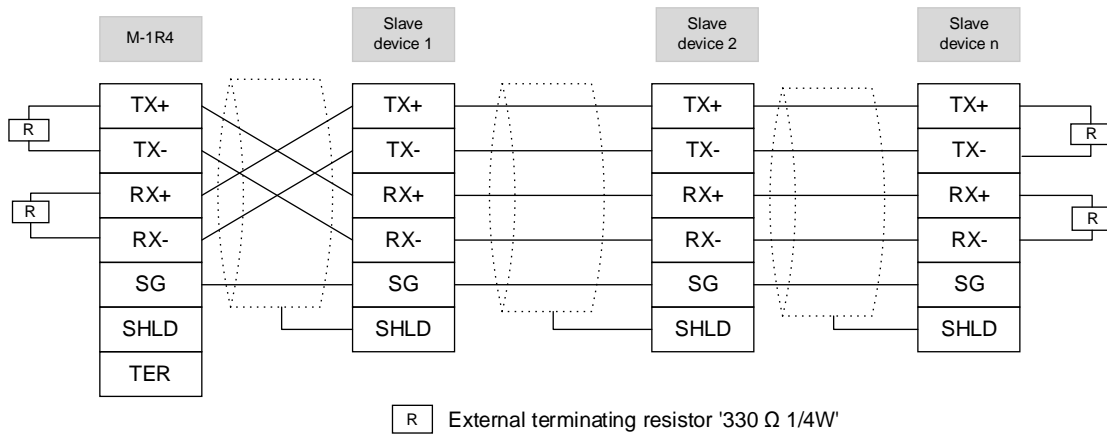

Connection example RS-485

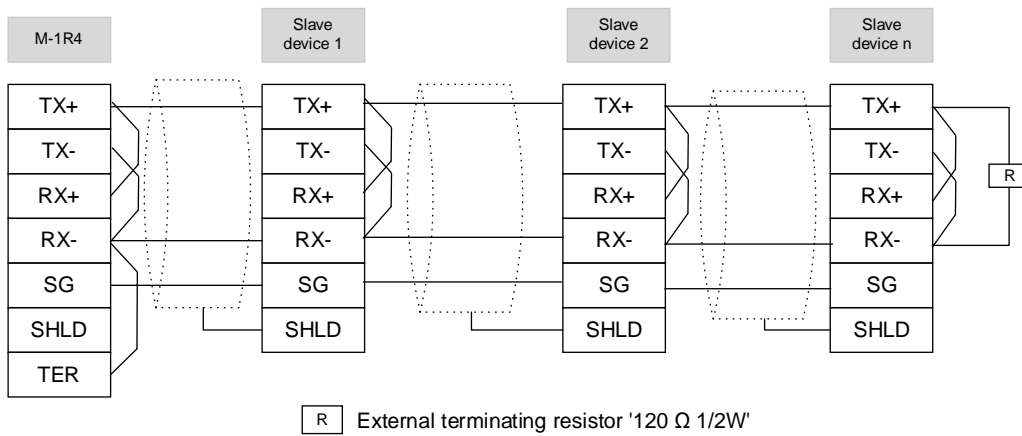

Parameters

Module M-1R4 can be configured using Modular IO Configurator. Refer section [Modular IO Configurator](#) for more details of module configuration.

Configuration of M-1R4 module involves configuration of Module parameters, Channel parameters and Operation mode parameters.

Module Parameters

The table below provides a list of module parameters that user can set.

Parameter Name	Project Value	Comment
Share diagnostics	Enable [Default]	Enables diagnostic data (SB) sharing with header.
	Disable	If enabled, module diagnostic data and channel diagnostic data is shared with header in SB memory

Channel Parameters

The table below provides a list of channel parameters that user can set as per application requirement.

Parameter Name	Project Value	Comment
Enable	Yes [Default] No	Enables/ disables channel
Baudrate	2400 4800 9600 [Default] 19200 38400 57600 115200	Select communication baud rate
Parity	None Odd [Default] Even	Select parity
No. of data bits	7 bits 8 bits [Default]	Select number of data bits
No. of stop bits	1 bit [Default] 2 bits	Select number of stop bits
Communication mode	Full Duplex Half Duplex [Default]	Select communication mode
Operation mode	Extended Modbus RTU master	This parameter decides the operation mode of module.

Operation mode parameters

The parameters specific to each operation mode are detailed in their respective sections.

Operation mode: Extended Modbus RTU Master

In 'Extended Modbus RTU Master' operation mode, M-1R4 module functions as built in Modbus RTU master. Up to 16 Modbus RTU slave devices can be connected to the channel. In this mode, module function as communication gateway to exchange data between header module and Modbus RTU slave devices.

Module can exchange up to 250 words read and 250 words write data with slave devices.

Below sections provides detail information about module behaviour, query handling, error handling, applicable parameters etc. along with example, in 'Extended Modbus RTU Master' mode.

[Overview](#)

[Modbus query configuration](#)

[Query execution methods](#)

[Manual trigger of query](#)

[Selective mapping of query data](#)

[Error handling](#)

[Operation mode parameters](#)

[IO data](#)

[Configuration example](#)

Overview

In this mode, M-1R4 works as Modbus RTU master. Modular IO station works as gateway between fieldbus master and Modbus RTU slave devices.

Module can be configured to communicate with up to 16 slave devices. User can configure up to 256 Modbus queries to exchange data with the slave devices. Module can exchange up to 250 words input and 250 words output data with the slave devices.

Note that amount of data exchanged with slave devices is also limited by maximum IO data size of header and data consumed by other IO modules in Modular IO station.

Following diagram summarises functioning of M-1R4 module in Extended Modbus RTU Master mode when header is interfaced with master station over CC-Link IE Field network.

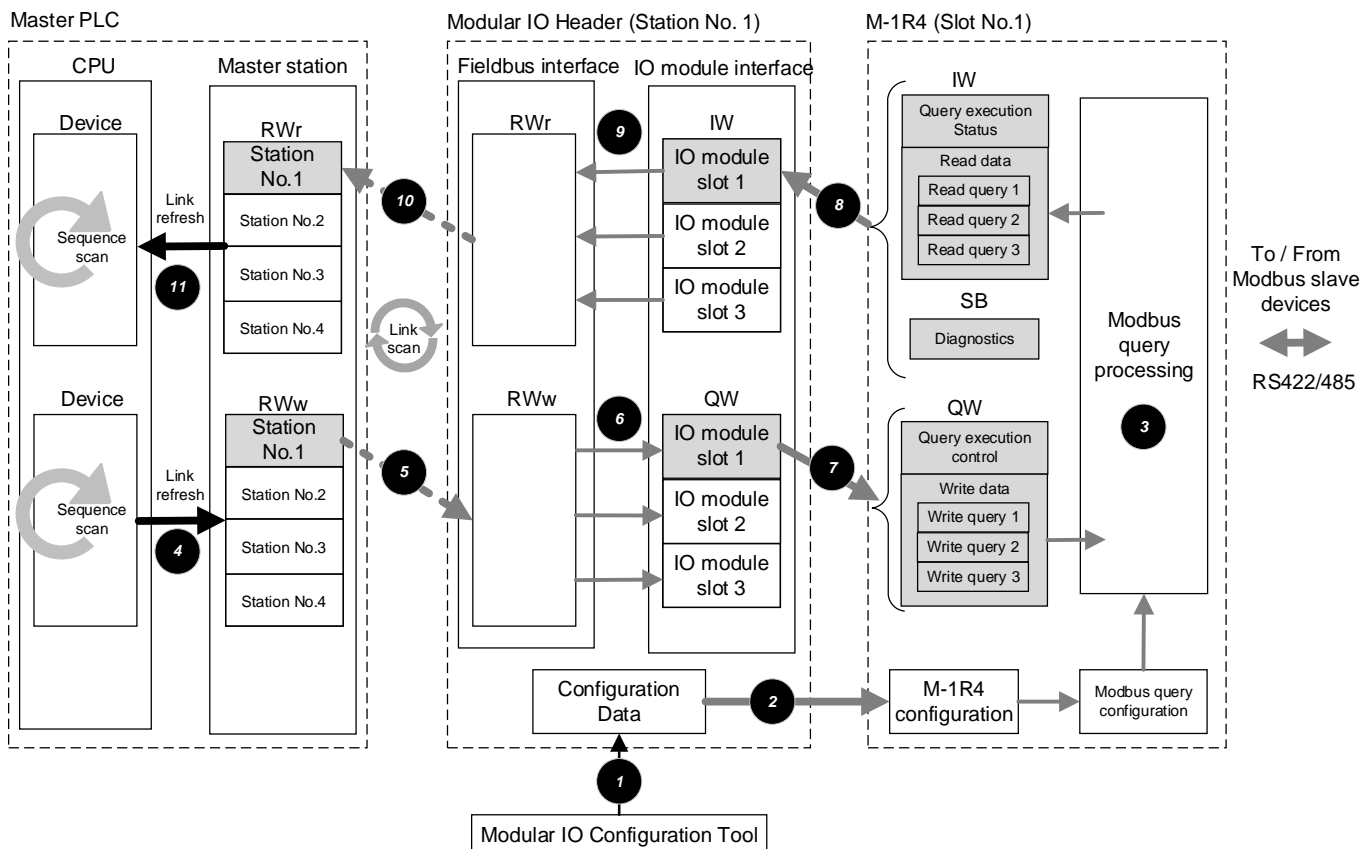

No.	Descriptions
1	User configures module configuration with Modbus queries in Modular IO configuration tool and downloads the configuration to header module.
2	During initialisation of M-1R4 module (header reset or power ON), header transfers configuration to the M-1R4 module.
3	In runtime, Modbus query processing engine in M-1R4 accesses query data to construct Modbus query packet to be sent to slave devices. For write type queries, 'Write data' from QW memory is used to construct query packet. For read type queries, data read from slave Modbus slave is copied to IW memory.

④	The 'Query execution control data' and 'Write data' for M-1R4 module (from devices of the CPU module) are stored in the link devices (RWw) of the master station through link refresh.
⑤	The data of the link devices (RWw) of the master station are transmitted to the link devices (RWw) of header module station by link scan.
⑥	The data of the link devices (RWw) is stored in the QW memory assigned for the M-1R4 module slot.
⑦	Header sends output data (QW) to M-1R4 module over backplane bus at predefined interval (500ms).
⑧	The Modbus query processing engine updates the IW and SB memory with query execution status data, read data, and diagnostic data. This information is sent to the header over the backplane bus at predefined intervals.
⑨	The data of IW and SB memory is stored in the link devices (RWw) of header module.
⑩	The data of the link devices (RWr) of the header module are transmitted to the link devices (RWr) of master station by link scan.
⑪	The link devices (RWr) of the master station are stored to CPU devices assigned to 'Query execution status' and 'Read data' for M-1R4 module through link refresh.

Modbus query configuration

Modular IO Configuration tool provided user friendly interface for configuration of Modbus queries. Refer section 'Configuration' for more details. This section explains example query configuration and parameters.

Following table shows example Modbus queries configuration.

Group No.	Query No	Add to cyclic scan	Slave device	Function code	Starting address	Quantity	Byte swapping	Selective mapping
1	1	Yes	1	03	1000	10	Disable	No
1	2	Yes	1	03	2000	20	Disable	No
1	3	No	1	03	3000	10	Disable	No
1	4	No	1	16	4000	6	Disable	No
2	1	Yes	2	03	1000	10	Disable	No
2	2	Yes	2	03	2000	20	Disable	No
2	3	No	2	03	3000	10	Disable	No
2	4	No	2	16	4000	5	Disable	No
3	1	Yes	3	03	1000	10	Disable	No
3	2	Yes	3	16	2000	20	Disable	No

Table below explains query parameters.

Item	Description									
Group No.	Group number of Query. Range 1 to 255. User can configure queries in different groups to control their execution sequence.									
Query No	Query numbers within a group ranges from 1 to 255. Each group starts its query numbering at 1. Total 255 queries can be configured across all groups.									
Add to cyclic scan	Parameter defines whether to add query to automatic or manual execution. Yes: Add a query in cyclic scan for sequential / groupwise execution. (Refer section 'Query execution methods' for more details.) No: Do not add this query to cyclic scan. Query can only be executed with manual trigger. (Refer section ' Manual trigger of query ' for more details.)									
Slave device	Defines slave device.									
Function code	Defines function code as <table border="1" style="margin-left: 20px;"> <thead> <tr> <th>Function Code</th> </tr> </thead> <tbody> <tr> <td>Read Coils (FC01)</td> </tr> <tr> <td>Read Discrete Inputs (FC02)</td> </tr> <tr> <td>Read Holding Registers FC03)</td> </tr> <tr> <td>Read Input Registers (FC04)</td> </tr> <tr> <td>Write Single Coil (FC05)</td> </tr> <tr> <td>Write Single Register (FC06)</td> </tr> <tr> <td>Write Multiple Coils (FC15)</td> </tr> <tr> <td>Write Multiple Registers (FC16)</td> </tr> </tbody> </table>	Function Code	Read Coils (FC01)	Read Discrete Inputs (FC02)	Read Holding Registers FC03)	Read Input Registers (FC04)	Write Single Coil (FC05)	Write Single Register (FC06)	Write Multiple Coils (FC15)	Write Multiple Registers (FC16)
Function Code										
Read Coils (FC01)										
Read Discrete Inputs (FC02)										
Read Holding Registers FC03)										
Read Input Registers (FC04)										
Write Single Coil (FC05)										
Write Single Register (FC06)										
Write Multiple Coils (FC15)										
Write Multiple Registers (FC16)										

Starting address	Defines start address to read / write. Setting range: 0 to 65535																		
Quantity	<p>Defines number of points to read or write. Setting range will depend on function code used.</p> <table border="1"> <thead> <tr> <th>Function Code</th> <th>Range</th> </tr> </thead> <tbody> <tr> <td>Read Coils (FC01)</td> <td>1 to 2000</td> </tr> <tr> <td>Read Discrete Inputs (FC02)</td> <td>1 to 2000</td> </tr> <tr> <td>Read Holding Registers FC03)</td> <td>1 to 125</td> </tr> <tr> <td>Read Input Registers (FC04)</td> <td>1 to 125</td> </tr> <tr> <td>Write Single Coil (FC05)</td> <td>1</td> </tr> <tr> <td>Write Single Register (FC06)</td> <td>1</td> </tr> <tr> <td>Write Multiple Coils (FC15)</td> <td>1 to 2000</td> </tr> <tr> <td>Write Multiple Registers (FC16)</td> <td>1 to 123</td> </tr> </tbody> </table>	Function Code	Range	Read Coils (FC01)	1 to 2000	Read Discrete Inputs (FC02)	1 to 2000	Read Holding Registers FC03)	1 to 125	Read Input Registers (FC04)	1 to 125	Write Single Coil (FC05)	1	Write Single Register (FC06)	1	Write Multiple Coils (FC15)	1 to 2000	Write Multiple Registers (FC16)	1 to 123
Function Code	Range																		
Read Coils (FC01)	1 to 2000																		
Read Discrete Inputs (FC02)	1 to 2000																		
Read Holding Registers FC03)	1 to 125																		
Read Input Registers (FC04)	1 to 125																		
Write Single Coil (FC05)	1																		
Write Single Register (FC06)	1																		
Write Multiple Coils (FC15)	1 to 2000																		
Write Multiple Registers (FC16)	1 to 123																		
Byte swapping	Enable / Disable byte swapping for word data.																		
Selective mapping	<p>Enable / disable selective mapping. This function is useful for sharing specific data with the header. For more details, refer to the 'Selective Mapping of query data' section.</p>																		

Query execution methods

In Extended Modbus RTU Master mode, two methods for query execution are available.

- Sequential query execution method
- Groupwise query execution method

Depending on application requirement, user can set 'Query execution method' in Basic Settings.

Query execution method decides order of queries executed in runtime and method of IO memory allocation for read data and write data of Modbus queries.

Sequential query execution:

As the name suggest, this method executes Modbus queries sequentially according to query number and group number. Read / write data of Modbus queries is mapped sequentially in IO memory.

Following section explains query execution and memory mapping in this method.

Query execution:

Queries can be executed either in cyclic scan or by manual trigger i.e. on demand. In cyclic scan, all queries with parameter 'Add to cyclic scan'=Yes are executed.

In cyclic scan, 'Group Select' value in query execution control memory (QW) decides execution of queries as explained in table below.

'Group Select' value	Query execution sequence
0	All the queries (with 'Add to cyclic scan' = Yes) of all the groups will be executed.
1	Queries of Group 1 (with 'Add to cyclic scan' = Yes) will be executed.
2 to 255	Queries (with 'Add to cyclic scan' = Yes) of Group 1 and selected group will be executed.

The following diagram explains cyclic scan operation in sequential query execution method.

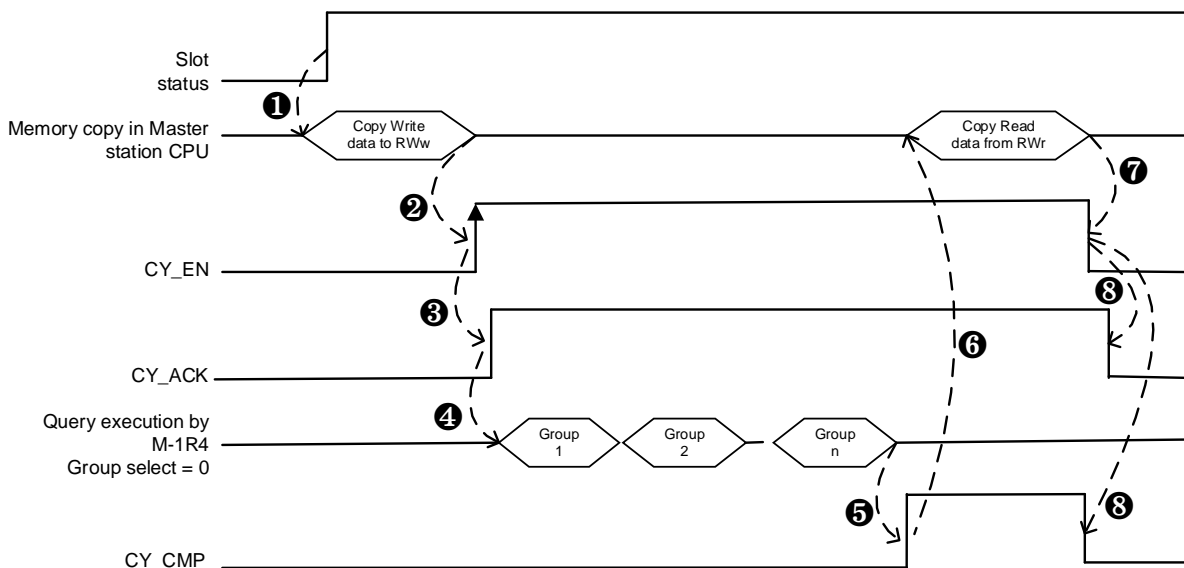

No.	Descriptions
1	Initially, if slot status of module is healthy write data of queries is copied to output memory.
2	After copying write data, 'CY_EN' (Enable cyclic execution) control bit in output memory is set to TRUE.

③	Module acknowledges 'CY_EN' control bit by status bit 'CY_ACK' in input memory. 'CY_ACK' will remain TRUE till 'CY_EN' is TRUE.
④	After CY_EN is acknowledged, module start executing Modbus queries according to 'Group select' value in output memory. Diagram shows execution of queries when Group select = 0. (Note 1)
⑤	After executing all queries, the module indicates the completion of execution by setting status bit CY_CMP in input memory to TRUE. Refer section ' Error handling ' for behaviour in case of error.
⑥	On receiving TRUE at CY_CMP, user application program should copy read data received in input memory.
⑦	CY_EN control bit from output memory is set to FALSE. (Note 2)
⑧	CY_ACK and CY_CMP status bit follows CY_EN control bit. (Note 3)

NOTE

- 'Group select' value is accepted on rising edge of 'CY_EN' command bit. Any change in value of 'Group select' will be ignored after rising edge of 'CY_EN' command bit,
- After completion of the first cyclic scan i.e status bit CY_CMP is set, cyclic scan of queries will continue from the first query as long as CY_EN is TRUE.
- When CY_EN is set to FALSE, module completes execution of query in process and after that updates status of status bits.

Memory mapping

In sequential execution method, input /output memory of the M-1R4 module will be allocated sequentially for all Modbus queries in the list.

The following table shows an example of sequential allocation of input output memory.

Group No.	Query No	Add to cyclic scan	Slave device	Function code	Starting address	Quantity	Byte swapping	Selective mapping	IO memory
1	1	Yes	1	03	1000	10	Disable	Disable	%IW10
1	2	Yes	1	03	2000	20	Disable	Disable	%IW20
1	3	No	1	03	3000	10	Disable	Disable	%IW40
1	4	No	1	16	4000	5	Disable	Disable	%QW10
2	1	Yes	2	03	1000	10	Disable	Disable	%IW50
2	2	Yes	2	03	2000	20	Disable	Disable	%IW60
2	3	No	2	03	3000	10	Disable	Disable	%IW80
2	4	No	2	16	4000	5	Disable	Disable	%QW15
3	1	Yes	3	02	1000	10	Disable	Disable	%IW90
3	2	Yes	3	16	2000	20	Disable	Disable	%QW20

In the example, query no. 1, 2, 3 of Group 1, query no. 1, 2, 3 of Group 2 and query no. 1 of Group 3 are read type queries.

Read data of these queries will be mapped in Input word memory (IW).

In sequential query allocation method, read data of all these queries will be mapped in input memory sequentially as shown in the table above.

Input data of Query no. 1, 2, 3 of Group No. 1 is mapped at offset 10 to 49.

Input data of Query no. 1, 2, 3 of Group No. 2 is mapped at offset 50 to 89.

Input data of Query no. 1 Group No. 3 is mapped at offset 90.

Similar sequential memory mapping will be applicable for output memory also.

NOTE

Start address of input and output memory for the M-1R4 module will depend on IO memory consumed by IO modules configured in the previous IO slots.

Groupwise query execution

This mode is particularly beneficial in situations where there is limited IO memory available for the M-1R4. For example, it may be necessary when the module is attached with a header module with a restricted IO memory capacity or when other modules configured in the Modular IO station result in less IO memory availability for the M-1R4.

In this mode, Modbus queries of only selected group are executed and IO data of M-1R4 module is repeatedly mapped to Modbus queries of each group. User should write application program to read / write IO data memory according group number to be executed before/after execution of queries.

The following section explains query execution and memory mapping in groupwise query execution method.

Query execution:

Cyclic and manual execution of queries is possible in Groupwise query execution method.

With cyclic scan, all the queries with 'Add to cyclic scan' setting = Yes' will be executed one by one automatically.

'Group Select' value in output memory (QW) decides execution of queries as explained in table below.

'Group Select' value	Query execution sequence
0	No query will be executed
1 to 255	All queries of selected group (with 'Add to cyclic scan' = yes) will be executed sequentially.

Following diagram explains cyclic scan operation in sequential query execution method.

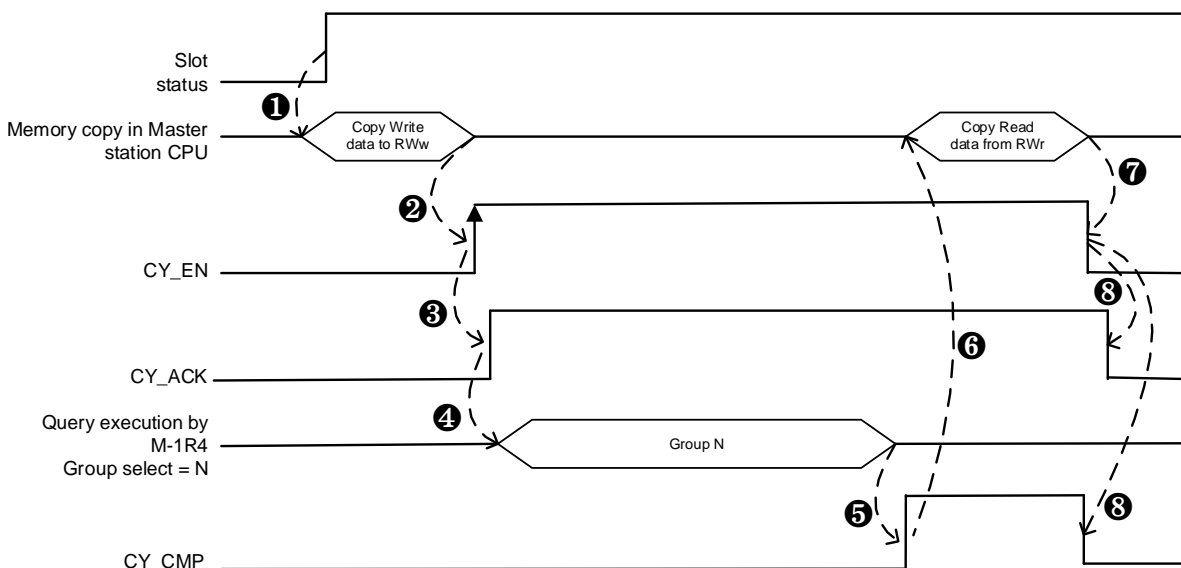

No.	Descriptions
1	Initially, if slot status of module is healthy write data of queries is copied to output memory. (Note 4)
2	After copying write data, 'CY_EN' (Enable cyclic execution) control bit in output memory is set to TRUE.
3	Module acknowledges 'CY_EN' control bit by status bit 'CY_ACK' in input memory. 'CY_ACK' will remain TRUE till 'CY_EN' is TRUE.
4	After CY_EN is acknowledged, module start executing Modbus queries according to 'Group select' value in output memory. Diagram shows execution of queries when Group select = N. (Note 1)

5	After executing all queries, the module indicates the completion of execution by setting status bit CY_CMP in input memory to TRUE. Refer section ' Error handling ' for behaviour in case of error.
6	On receiving TRUE at CY_CMP, user application program should copy read data received in input memory. (Note 4).
7	CY_EN control bit from output memory is set to FALSE. (Note 2)
8	CY_ACK and CY_CMP status bit follows CY_EN control bit. (Note 3)

NOTE

- 'Group select' value is accepted on rising edge of 'CY_EN' command bit. Any change in value of 'Group select' will be ignored after rising edge of 'CY_EN' command bit.
- After completion of the first cyclic scan i.e status bit CY_CMP is set and cyclic scan of queries will be stopped. To start query execution again user has to toggle 'CY_EN' command bit.
- When CY_EN is set to FALSE, module completes execution of query in process and after that updates status of status bits.
- Note that in groupwise execution method, IO memory of M-1R4 is re-used to store read / write data of Modbus queries of selected group. Hence, context of IO data changes depending on value of 'Group select'. The Application program should ensure that the IO data is copied to the appropriate memory locations assigned for the Modbus queries of the selected group.

Memory mapping

In groupwise execution method, input /output memory of COM module will be allocated repeatedly for each group of Modbus queries.

The following table shows example of groupwise allocation of input output memory.

Group No.	Query No	Add to cyclic scan	Slave device	Function code	Starting address	Quantity	Byte swapping	Selective mapping	IO memory
1	1	Y	1	03	1000	10	Disable	Disable	%IW10
1	2	Y	1	03	2000	20	Disable	Disable	%IW20
1	3	N	1	03	3000	10	Disable	Disable	%IW40
1	4	N	1	16	4000	5	Disable	Disable	%QW10
2	1	Y	2	03	1000	10	Disable	Disable	%IW10
2	2	Y	2	03	2000	20	Disable	Disable	%IW20
2	3	N	2	03	3000	10	Disable	Disable	%IW40
2	4	N	2	16	4000	5	Disable	Disable	%QW10
3	1	Y	3	02	1000	10	Disable	Disable	%IW10
3	2	Y	3	16	2000	20	Disable	Disable	%QW10

In example, query no. 1, 2, 3 of group1, query no. 1, 2, 3 of group 2 and query no. 1 of group 3 are read type queries.

Read data of these queries will be mapped in Input word memory (IW).

In groupwise query execution method, input memory is re-allocated to each group as shown in the table above.

Input data of Query no. 1, 2, 3 of Group No. 1 is mapped at offset 10 to 49.

Input data of Query no. 1, 2, 3 of Group No. 2 is mapped at offset 10 to 49.

Input data of Query no. 1 Group No. 3 is mapped at offset 10, offset 11 to 49 will remain unused.

Similar memory mapping will be applicable for output memory also.

Manual trigger of query

In both sequential and groupwise query execution methods, manual execution of queries can be triggered while cyclic scan of queries is in process. On receiving trigger for manual execution, cyclic scan of queries is paused after completion of query under execution and manual query is executed on priority.

The following diagram shows execution of manual query.

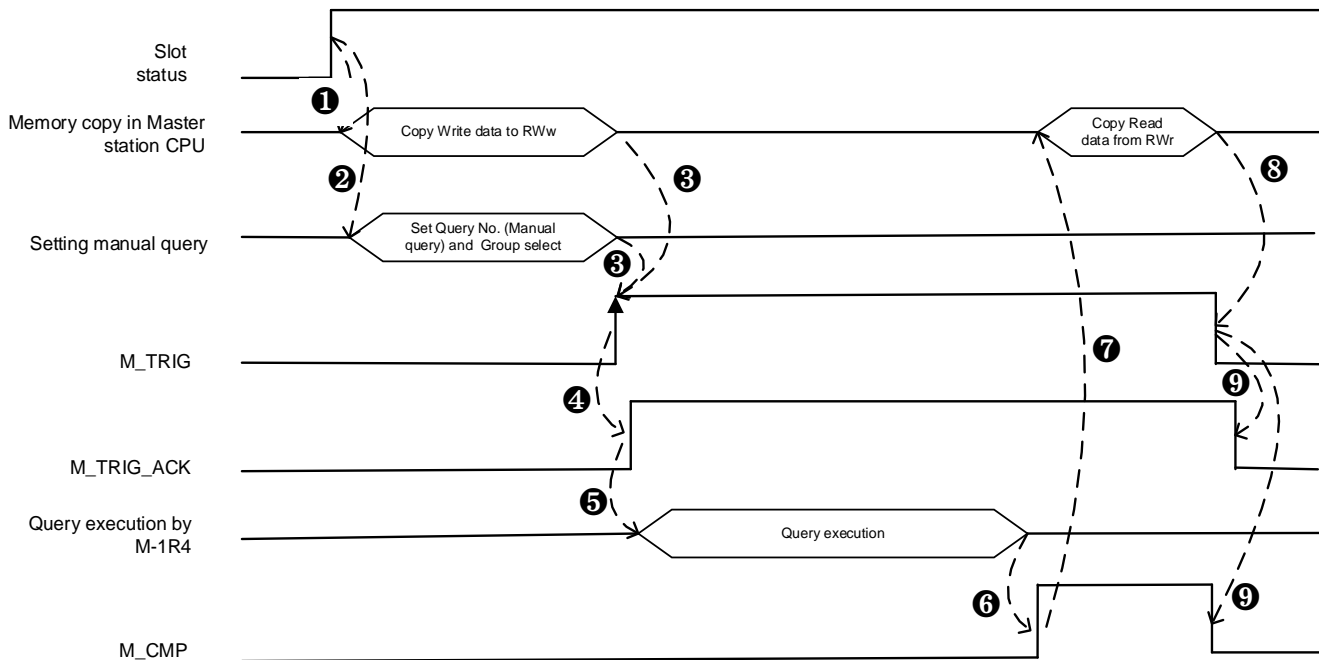

No.	Descriptions
①	Initially, if slot status of module is healthy, write data of query to be executed is copied to output memory. This is applicable for write type Modbus queries only.
②	Set value of 'Query No. (Manual query)' in output memory. Group number of manual query execution is set by 'Group Select' set for cyclic execution.
③	To trigger manual query, set control bit 'M_TRIG' in output memory.
④	Module acknowledges 'M_TRIG' control bit by status bit 'M_TRIG_ACK' in input memory. 'M_TRIG_ACK' will remain TRUE till 'M_TRIG' is TRUE.
⑤	After M_TRIG is acknowledged, module executes Modbus query according to 'Query No. (Manual query)' and 'Group select' value in output memory. (Note 1)
⑥	After executing the query, the module indicates the completion of execution by setting status bit M_CMP in input memory to TRUE. Refer section ' Error handling ' for behaviour in case of error.
⑦	On receiving TRUE at M_CMP, user application program should copy read data received in input memory. This is applicable for read type Modbus queries only.
⑧	M_TRIG control bit from output memory is set to FALSE.
⑨	M_TRIG_ACK and M_CMP status bit follows M_TRIG control bit. (Note 2)

NOTE

1. If CY_EN is TRUE, the 'Group select' value is accepted on the rising edge of the CY_EN command bit and the Query No. (Manual query) is accepted on the rising edge of M_TRIG.
If CY_EN is FALSE, both the 'Group select' and the Query No. (Manual query) are accepted on the rising edge of M_TRIG.
This means that if a cyclic scan is in progress, a manual query can be executed from the same selected group.
2. When M_TRIG is set to FALSE while query is under execution, module completes execution of query in process and after that updates status of status bits.

Selective mapping of query data

You can set 'Selective mapping' of query data for Modbus queries executed with Function code 03 (Read Holding Registers) and function code 04 (Read Input Registers).

This function enables you to choose the data from the Modbus RTU slave device to be mapped into the input memory (IW) in the header, which is then transmitted to the fieldbus master.

When to use?

To enhance overall communication performance, it is recommended to minimize the number of queries sent to the slave device. This can be accomplished by sending a single query to read multiple application data from the slave device. However, in slave device, the required data may not be available in sequential Modbus registers. In such instances, Selective Mapping of query data can be configured.

Example: Consider energy measuring Modbus slave device with following mapping for an example.

Modbus Address	Data	To be shared over fieldbus
40100 - 40103	Phase current values (I1, I2, I3 and IN)	Yes
40104 - 40107	Demand current (I1, I2, I3 and IN)	No
40108 - 40110	Phase voltages (V1, V2, V3)	Yes
40111 - 40113	Harmonic phase voltages (V1, V2, V3)	No
40114 - 40116	Power factor (PF1, PF2, PF3)	No
40117 - 40120	Line voltages (V12, V23, V31)	Yes
40121 - 40123	Harmonic phase voltages (V1, V2, V3)	No

Here, the application requirement is to share only voltage and current values with fieldbus master as shown in above table.

In this case, you have two options.

1. Send three separate queries to read Phase current (40100 – 40103), Phase voltage (40108 – 40110) and Line voltage (40117 – 40120).
2. Send single query to read Modbus registers 40100 to 40120.
Use selective mapping to share only required data to fieldbus master.

In the first option, as three Modbus queries are executed, it will require more time to update all the required values.

In the second option, only one Modbus query is sent to read all information from the slave device, overall communication performance between communication module and slave device will be improved.

In 'Selective mapping', user can choose read data to be mapped in IW memory.

Refer section '[Configuration Example](#)' for. Details.

Error handling

Serial communication errors:

Errors encountered during serial transmission / reception are mapped in SB memory area as below.

- Receive buffer overflow
- Parity error
- Framing error

User can reset these errors using control bits RST or RST_ERR signal of output memory (QW).

Error status:

If error is detected during execution of a Modbus queries (cyclic or manual), it is specified by following input memory (IW) items. The latest error information will be updated in this memory.

Status	Data type	Description	Applicable for	Cleared if
CY_ERR (Cyclic execution error)	BOOL	Bit 3 of 'Status bits' in IW memory. Indicates error occurred for one or more queries of cyclic scan.	Cyclic scan only	<ul style="list-style-type: none"> • RST_ERR (Bit 3 of 'Control bits' in QW memory) is set to TRUE. • RST (Bit 0 of 'Control bits' in QW memory) is set to TRUE. • CY_EN (Bit 1 of 'Control bits' in QW memory) is set to FALSE.
Error code (Cyclic query)	WORD	Holds error code for recent query executed with error in cyclic scan.		
Group No. (Cyclic query error)	BYTE	Holds group number of recent query executed cyclically with error.		
Query No. (Cyclic query error)	BYTE	Holds query number of recent query executed cyclically with error.		
M_ERR (Manual execution error)	BOOL	Bit 6 of 'Status bits' in IW memory. Indicates error occurred during execution of manual query.	Manual trigger only	<ul style="list-style-type: none"> • RST_ERR is set to TRUE. • RST is set to TRUE. • M_TRIG (Bit 2 of 'Control bits' in QW memory) is set to FALSE.
Error code (Manual query)	BYTE	Holds error code for recent query executed with error with manual trigger.		
Slave device error (bit-wise)	WORD	<p>Holds bitwise error status of each slave.</p> <p>Bit 0 – Station 1, Bit 1 – Station 2...Bit 15 – Station 16</p> <p>TRUE – Error detected for slave FALSE – No error.</p> <p>Bit will be set if error is detected while executing a query (cyclic or manual). Here 'Station 1' is name of station in MIO tool and not station ID assigned.</p> <p>If word value is non zero, it is indicated by ERR LED (single flash).</p>	Cyclic scan and Manual trigger	<ul style="list-style-type: none"> • RST_ERR is set to TRUE. • RST is set to TRUE. • Communication resumed (No error in cyclic and Manual query execution). • CY_EN (Bit 1 of 'Control bits' in QW memory) and M_TRIG (Bit 2 of 'Control bits' in QW memory) is set to FALSE.

Points to be noted for handling error during communication,

- When an error is detected during Modbus query execution, the module will attempt to resend the same query the number of times specified by operation mode parameter 'Retry count'.

If error continues after retries, 'Slave device error (bitwise)' for slave device is set to TRUE in input memory (IW). Once device error is set, new query will not be sent to that slave in current cyclic scan.

- Before starting a new cyclic scan, module will check value of parameter 'Auto reconnect'.
If the 'Auto reconnect' parameter is set to 'Yes', the module will attempt to execute a Modbus query for a slave device in each cyclic scan. If an error occurs, subsequent queries for that slave will not be executed in that cyclic scan. Error status is updated in 'CY_ERR', 'Cyclic error code', 'Group no. (Cyclic query error)', 'Query no. (Cyclic query error)' and 'Slave device error (bit-wise)'.
If reconnection is successful, the 'Slave device error (bit-wise)' will be cleared and subsequent queries for that slave will be executed in that cyclic scan. Error status 'CY_ERR', 'Cyclic error code', 'Group no. (Cyclic query error)', and 'Query no. (Cyclic query error)' will be continued to inform last error detected in cyclic scan. Errors can also be identified by checking the 'No of Modbus queries with error' in the SB memory area.
If 'Auto reconnect' is set to 'No', the slave error status is not cleared.
The module will not send any query to a slave in subsequent cyclic scans. The user should reset the Modbus error using the RST and 'RST_ERR' control bits in the output memory (QW). Alternatively, the error can be reset by setting CY_EN to FALSE.

Error codes

Below is list of error codes,

Error code	Details	Details
0	No error	Query execution not initiated or executed without error.
1	Illegal function	The function code received in the request is not an authorized action for the slave. The slave may be in the wrong state to process a specific request.
2	Illegal data address	The data address received by the slave is not an authorized address for the slave.
3	Illegal data value	The value in the request data field is not an authorized value for the slave.
4	Slave device failure	The slave fails to perform a requested action because of an unrecoverable error.
5	Acknowledge	The slave accepts the request but needs a long time to process it.
6	Slave device busy	The slave is busy processing another command. The master must send the request once the slave is available.
7	Negative acknowledgment	The slave cannot perform the programming request sent by the master.
8	Memory parity error	The slave detects a parity error in the memory when attempting to read extended memory.
9	Reserved	Reserved
10	Gateway path unavailable	The gateway is overloaded or not correctly configured.
11	Gateway target device failed to respond	The slave is not present on the network.
12 to 247	Reserved	Reserved
248	Invalid manual query selected	Query number set in 'Query No. (Manual query)' is not configured for selected group.
250	Checksum error	Checksum error detected in response received from slave device.
251	Reserved	Reserved
252	Invalid response received	Invalid response received to a Modbus query sent by module. Response is checked for <ul style="list-style-type: none"> Function code in response is different than function code in query. Slave address in response is different than slave address in query. Length of data received in query is not matching with expectation. Write Single Coil (FC05) or Write Single Register (FC06) query received invalid response (not matching with query).
255	Timeout error	No response received from slave device in time specified by parameter 'Timeout'.

NOTE

Error codes 1 to 11 are Modbus exception codes received from slave device. Refer slave device user's manual for more details.

Operation mode parameters

In addition to mandatory parameters and module specific parameters, below is the list of parameters applicable for operation mode 'Extended Modbus RTU master'.

Parameter Name	Project Value	Comment
Size of read data	10 [Default] Setting range: 0 to 250 words	Parameter defines size of IW memory allocated to store data read from slave devices. This parameter is set from 'Basic settings' of 'Modbus query editor'
Size of write data	10 [Default] Setting range: 0 to 250 words	Parameter defines size of QW memory allocated to store data to be written to slave devices. This parameter is set from 'Basic settings' of 'Modbus query editor'
Query execution method	Sequential [Default] Group wise	Defines query execution method. Sequential or Groupwise This parameter is set from 'Basic settings' of 'Modbus query editor' Refer section ' Query execution methods ' for more details.
Auto reconnect	Yes [Default] No	This parameter defines whether module should attempt to send Modbus queries to slave device in case of error. Refer section ' Error handling ' for more details.
Timeout	250 [Default] Supported: up to 60000 msecs	After sending a query, if expected numbers of bytes are not received before elapse of timeout period, then 'Timeout Error' is declared.
Retry count	3 [Default] Setting range: 0 to 5	This parameter holds number of retries to be executed in case of communication error before declaring slave device error.

IO Data

IX and QX memory

The M-1R4 module does not consume IX and QX memory.

IW Memory

IW memory hold status information and read data as shown below.

Channel	Data Type	Local Address	Status	Comment
Status bits	BYTE	%IWn (Byte 0)		Holds bitwise status of query execution.
RST_ACK	BOOL	%IWn.0	TRUE	Reset communication successful
			FALSE	Reset not initiated or reset is in progress.
CY_ACK	BOOL	%IWn.1	TRUE	CY_EN is executed i.e. Cyclic communication is started with configured slave devices.
			FALSE	CY_EN not initiated or is in progress.
CY_CMP	BOOL	%IWn.2	TRUE	Execution of cyclic scan is completed.
			FALSE	Execution of cyclic scan is not started or is in progress.
CY_ERR	BOOL	%IWn.3	TRUE	Error is detected for one or more queries while executing cyclic scan. Refer 'Slave device error (bitwise)' for the details.
			FALSE	No error detected while executing cyclic scan.
M_TRIG_ACK	BOOL	%IWn.4	TRUE	Manual query request is accepted by module.
			FALSE	Manual query request is not initiated or accepted by module.
M_CMP	BOOL	%IWn.5	TRUE	Execution of manual query is completed successfully.
			FALSE	Execution of manual query is not started or is in progress.
M_ERR	BOOL	%IWn.6	TRUE	Error is detected for while executing manual query. Refer 'Slave device error (bitwise)' for the details.
			FALSE	No error detected while executing manual query.
CONF_ERR	BOOL	%IWn.7	TRUE	No or invalid Modbus query configuration detected by the module
			FALSE	Valid Modbus query configuration available with the module.
Error code (Manual query)	BYTE	%IWn (Byte 1)		Holds error code for recent query executed with error with manual trigger.
Group No. (Cyclic query)	BYTE	%IWn+1 (Byte 0)		Holds group number of the most recently executed cyclic scan query.
Query No. (Cyclic query)	BYTE	%IWn+1. (Byte 1)		Holds query number of the most recently executed cyclic scan query.
Group No. (Cyclic query error)	BYTE	%IWn+2. (Byte 0)		Holds group number of query where error is detected during execution of cyclic scan.

Query No. (Cyclic query error)	BYTE	%IWn+2. (Byte 1)	Holds query number of query where error is detected during execution of cyclic scan.
Error code (Cyclic query)	WORD	%IWn+3	Holds the error code of the recent query that encountered an error during a cyclic scan. Refer section ' Error handling ' for more details.
Slave device error (bit-wise)	WORD	%IWn+4	Holds bitwise error status of each slave. Bit 0 – Station 1, Bit 1 – Station 2....Bit 15 – Station 16 TRUE – Error detected for slave. FALSE – No error. Bit will be set if error is detected while executing a query (cyclic or manual). Here 'Station 1' is name of station in MIO tool and not station ID assigned.
Read data	ARRAY_OF_WORD	%IWn+5 onwards	Read data of queries is stored sequentially. Size of array is set by parameter 'Size of read data'

NOTE

Start address of input memory (n) for the M-1R4 module will depend on IO memory consumed by IO modules configured in the previous IO slots.

QW memory

QW memory holds control word and transmit data as shown below.

Channel	Data Type	Local Address	Status	Comment
Control bits	WORD	%QWm		
RST	BOOL	%QWm.0	TRUE	At rising edge, communication channel is re-initialised. Modbus communication status, counters are reset.
			FALSE	Reset is not initiated.
CY_EN	BOOL	%QWm.1	TRUE	Execution of cyclic scan is initiated.
			FALSE	Execution of cyclic scan is not initiated.
M_TRIG	BOOL	%QWm.2	TRUE	At rising edge, execution of manual query is triggered.
			FALSE	Execution of manual query is not initiated.
RST_ERR	BOOL	%QWm.3	TRUE	Clears following error information <ul style="list-style-type: none"> Parity error, framing error, receive buffer overflow error detected during reception CY_ERR, Group No.(Cyclic query error), Query No.(Cyclic query error), Error code (Cyclic query) M_ERR, Error code (Manual query) Slave device error (bit-wise).
			FALSE	Clear error command not triggered.

CLR_CNT	BOOL	%QWm.4	TRUE	Clears following counters from SB memory <ul style="list-style-type: none"> No. of Modbus queries sent No. of valid Modbus replies received No. of Modbus queries executed with error.
			FALSE	Clear counters command not triggered
Group select	WORD	%QWm+1	Sets 'Group select' for queries to be executed as per query execution method set. Refer section ' Query execution methods ' for more details.	
Query No. (Manual query)	WORD	%QWm+2	Sets query number for manual query execution.	
Write data	BYTE	%QWm+3 onwards	Write data of queries is stored sequentially. Size of array is set by parameter 'Size of write data'	

NOTE

Start address of output memory (m) for the M-1R4 module will depend on IO memory consumed by IO modules configured in the previous IO slots.

SB memory

User can monitor the following diagnostics in SB memory.

Channel	Data Type	* Local Address	Status	Comment
Module Diagnostics	BYTE	SB (n)	--	Holds bitwise control data of query execution.
No field power supply	BOOL	SB (n).0	TRUE	24 VDC field power supply is absent.
			FALSE	24 VDC field power supply is present.
RX buffer overflow	BOOL	SB (n).1	TRUE	Receive buffer is full. Receive buffer size is 512 bytes.
			FALSE	No receive buffer overflow error.
Parity error	BOOL	SB (n).2	TRUE	Parity error occur during data reception.. In case of parity error, received byte is not copied to receive buffer of module.
			FALSE	No parity error.
Framing error	BOOL	SB (n).3	TRUE	Framing error occur during data reception. In case of framing error, received byte is not copied to receive buffer of module.
			FALSE	No framing error
--	BOOL	SB (n).4 to SB (n).7	--	Reserved
No. of Modbus queries sent	BYTE	SB (n+1)		Number of Modbus queries sent by module. Value will rollover after 255.
No. of valid Modbus replies	BYTE	SB (n+2)		Number of valid Modbus replies received by module i.e. Number of successfully executed queries. Value will rollover after 255.
No. of Modbus queries with error	BYTE	SB (n+3)		Number of Modbus queries executed with error. Value will rollover after 255.

NOTE

Start address of SB memory (n) for the M-1R4 module will depend on IO memory consumed by IO modules configured in the previous IO slots.

Configuration Example

Configuration steps

The following flowchart shows configuration steps for the M-1R4.

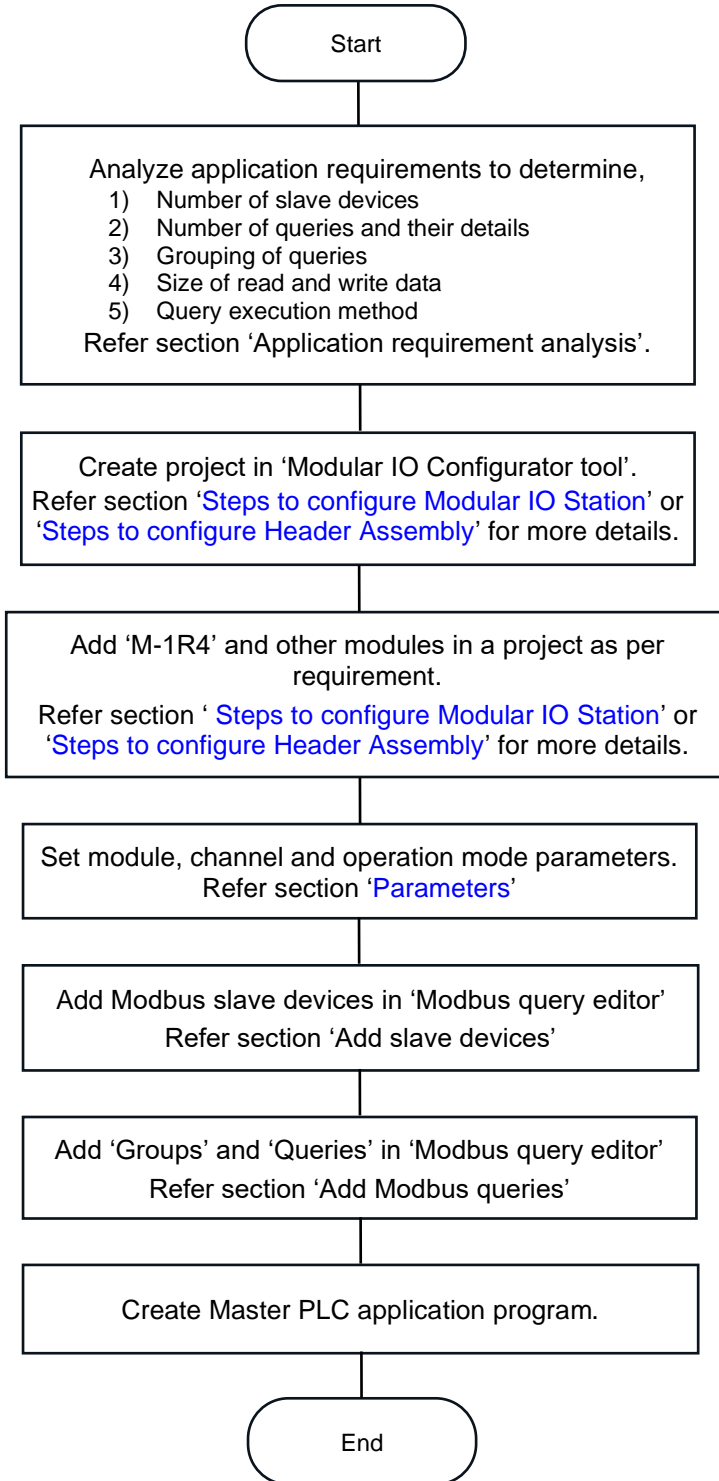

Application requirement analysis:

1) Number of slave devices

Determine number of slave devices and their station IDs to be communicated over RS485 link.

The M-1R4 module allows configuration of up to 16 slave stations.

2) Number of queries and their details

Determine data to be read / write from / to each slave device.

Here, determine Modbus function code, Modbus address and size of data for each query.

For better communication performance it is advised to optimize the number of queries configured for each slave device. Use selective mapping function to combine multiple read requests.

Refer section '[Selective mapping of query data](#)' for more details.

3) Grouping of queries

To effectively manage the execution sequence of queries and the mapping of read/write data, it is beneficial to group queries. Queries can be grouped based on the station ID or functionality.

Example 1: Group all queries for a single slave device together to execute them sequentially. This approach ensures that all queries for a specific slave device are processed one after the other, and also allows for sequential mapping of read/write data for that device.

Example 2: Group queries based on device functionality. For instance, in an application with 16 slave devices, comprising 4 energy meters, 4 pressure transmitters, and 8 inverters, you can create separate groups for each type: one for all energy meters, one for all pressure transmitters, and one for all inverters. This approach helps in mapping data with the same functionality together.

Example 3: Group Modbus queries by machine operation, organizing all queries related to a specific machine operation into a single group. For instance, in a molding machine, queries related to different sections such as mold clamping, heating zones, and ejector control can be grouped together. This approach helps sequential memory mapping of read / write data of queries associated with specific operational area.

4) Size of read and write data

The M-1R4 module supports:

- 250 words of read data (IW): This is the input data that the module reads from the slave devices.
- 250 words of write data (QW): This is the output data that the module sends to the slave devices.

Identify the number of queries and the amount of data each query reads from the slave devices.

Compute sum of data size of all read queries.

Similarly, identify the number of queries and the amount of data each query writes to the slave devices.

Computer sum of data size of all write queries.

5) Decide 'Query execution method'

Based on the size of read and write data of each query group, decide query execution method.

Sequential query execution:

- This method is easy to use and requires less effort for programming in Master PLC.
- You can use this method if total size of read data + status memory (5 words) doesn't exceed IW memory available for M-1R4 module.
Similarly, total size of write data + control memory (3 words) should not exceed QW memory available for M-1R4 module.
- IW and QW memory available for the M-1R4 module will depend on following factors.
 - Header module capacity - Size of IW / QW memory supported by header.
 - Other IO modules configured - Size of IW / QW memory consumed by IO modules configured in previous IO slots.

Groupwise execution method:

User can use this method if size of read / write data of queries exceeds available IO memory.

Example -

If 16 slave devices are to communicate.

For storing data read from each slave device, you require IW = 64 words, QW =16 words.

Total size of IW requirement = 64 x 16 = 1024 words.

It is not possible to allocate 1024 words of IW memory for M-1R4 module. In such situations, you should select a groupwise allocation method where same input / output memory is re-used for each group.

Make 16 groups (one group for each device) in this case.

So, IW memory required to store read data is 64 words and QW memory required to store write data is 16 words.

Set parameters:

Set module parameters and channel parameters

Select M-1R4 module and click on 'Parameters' tab and set parameters.

Parameter Name	Project Value	Online Value
Module parameters		
Share diagnostics	Enable	Enables diagnostic data
CH0 parameters		
Enable	Yes	Enable / disable channel
Baudrate	9600	Communication baudrate
Parity	Odd	Parity selection
No. of data bits	8 bits	No. of data bits
No. of stop bits	1 bit	No. of stop bits
Communication Mode	Half Duplex	Communication Mode
Operation Mode	Extended Modbus RTU Mode	protocol type

Refer section 'Parameters' to configure 'Module parameters' and 'CH0 parameters'.

Set 'Extended Modbus RTU Master' mode specific parameters.

Note that parameters 'Size of queries IW data', 'Size of queries QW data' and 'Query execution method' are set from Modbus Query Editor.

Parameter Name	Project Value	Online Value
Extended Modbus communication mode parameters		
Size of Queries IW data	10	Size of Queries IW memory reserved for module
Size of Queries QW data	10	Size of Queries QW memory reserved for module
Query execution method	Sequential	Query execution method (This Parameter will be set from Modbus Query Editor)
Auto reconnect	Yes	Defines behaviour on communication error
Timeout	250	Communication timeout in milliseconds
Retry Count	3	No. of Retries

Refer section Parameters – 'Extended Modbus RTU Master' mode for more details.

Note that few operation mode parameters are set from Modbus query editor → Basic settings as shown below.

Name	Value	Comment
Size of Queries IW data	10	Size of Queries IW memory reserved for module (This Parameter will be set from Modbus Query Editor)
Size of Queries QW data	10	Size of Queries QW memory reserved for module (This Parameter will be set from Modbus Query Editor)
Query execution method	Sequential	Query execution method (This Parameter will be set from Modbus Query Editor)



Refer section Parameters – 'Extended Modbus RTU Master' mode for more details.

Add slave devices:

This tab shows list of slave devices and their station IDs. User can add up to 16 slave devices in the list.



Following are details of buttons on the tab

Tab/ Button	Description
	Add Slave Device. User can add slave devices as 'Station 1, Station 2, Station 3...., Station 16 etc.
	Delete Slave Device User can delete selected slave device from the list.



Add Modbus Queries

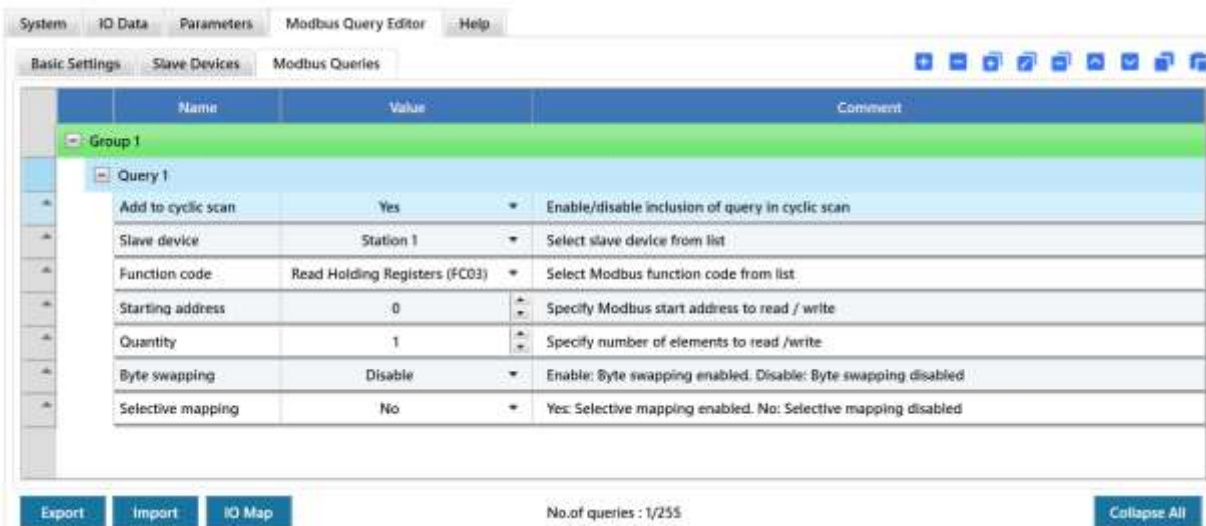









With 'Modbus Queries' tab, user can configure properties for individual query and also define groups of queries as shown below.



The table below provides details of tabs or buttons 'Modbus Queries',

To add a new query, the user must first create a query group. Once the group is created, each click on 'Add query' will add a new query to the selected group.

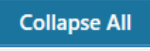
Tab/ Button	Description
	'Query Add' button. Adds new Modbus query in selected group of query list.
	'Query Delete' button. Deletes selected Modbus query from query list.
	'Group Add' button. Adds new query group.

	'Group Edit' button. Opens 'EDIT GROUP NUMBER' dialogue.
	'Group Delete' button. Deletes selected query group.
	'Query Up' button. Move up selected query in same group.
	'Query Down' button. Move down selected query in same group.
	'Copy' button. Copies selected query / query group.
	'Paste' button. Paste copied query / query group at selected location.
	Exports Modbus query configuration to a <i>.mioexp</i> file. Exported configuration can be imported in another project / another module in same project.
	Imports Modbus query configuration from a <i>.mioexp</i> file. Modbus query configuration exported from another project / module can be imported.
	Opens 'IO MAPPING' dialogue. IO mapping dialogue shows mapping of input and outputs of serial communication module to IW / QW memory of header. Refer section ' IO mapping ' for more details.
 	Expands / collapse configured queries and groups.

[Back To Index Page](#)

10 Troubleshooting

[List of station Error Codes](#)

[List of info and error messages](#)

[LED indications: States and flashing rates](#)

List of Station Error Codes

The table below provides list of error codes.

Error Code	Classification	Error Name	Applicable Module	Description
1000H	Fatal	Hardware failure	All modules	Module hardware error
1001H	Fatal	Firmware watchdog error	All modules	Firmware watchdog error detected on the module
1002H	Fatal	Configuration error	All modules	Configuration data invalid.
1003H	Fatal	Module absent or mismatch error	IO modules	Either module configured in slot is different than the module is actually present or Module is absent
1004H	Fatal	IO module COM error	IO modules	If data exchange between Header and one or more IO modules is stopped after successful data exchange.
1005H	Fatal	IP address setting out of range	M-CCIEF-H	IP address setting switch out of range error
1006H	Reserved			
1007H	Fatal	Factory calibration error	M-UAD2, M-AD4, M-ADV8, M-ADI8 M-TCRT4	Invalid factory calibration data detected.
1008H	Fatal	CJC error	M-UAD2, M-TCRT4	CJC error detected
1009H	Fatal	Invalid parameter	All modules	Parameter read / write request received for unknown parameter
100BH to 100EH	Reserved			
1010H	Fatal	Loss of header	M-CCIEF-H	Lost communication with redundant header module. Only applicable to M-CCIEF-H in redundant configuration.
1011H	Fatal	Header module mismatch	M-CCIEF-H	Non-compatible (ordering code mismatch) header module is present in another header slot. Only applicable for redundant configuration.
1012H	Fatal	Header module version not compatible	M-CCIEF-H	Non-compatible (device version mismatch) header module is present in another header slot. Only applicable for redundant configuration.
1013H	Fatal	Station number out of range	M-CCIEF-H	Station number set by rotary switch is out of range.
1014H	Fatal	Header assembly module detection error	M-CCIEF-H	Header assembly module (power supply module or IO adapter module) not detected.
1015H to 1FFE H	Reserved			
1FFFH	Fatal	Fatal fieldbus error	All header modules	Fatal fieldbus error detected. Further diagnosis related to fieldbus can be monitored in header diagnostic.

2000H	Non-Fatal	Field power absent	All modules	Field power is absent at header module
2001H	Non-Fatal	IP address setting switch is changed	Header module	IP address setting switch has been changed while keeping the module power on.
2003H	Non-Fatal	Additional IO modules detected	Header module	All configured IO modules are present. Additional IO module detected by Header.
2004H	Non-Fatal	Error detected during configuration copy to standby header	M-CCIEF-H	Error detected while copying configuration data to standby header. Only applicable for redundant configuration.
2005H	Non-Fatal	Waiting for configuration	M-CCIEF-H	Standby header is waiting for configuration from control header. Only applicable for redundant configuration.
2006H	Non-Fatal	Standby module error	M-CCIEF-H	Error detected for Standby module resulting in loss of redundancy. Only applicable for redundant configuration.
2007H	Non-Fatal	Additional header module detected	M-CCIEF-H	Additional header module is detected in non-redundant configuration.
2008H	Non-Fatal	Station number changed while power is ON	M-CCIEF-H	Station number switch is changed during power ON.
2009H	Non-Fatal	P1 Power supply module not detected	M-CCIEF-H	Power supply module in P1 slot is configured but not detected.
2010H	Non-Fatal	P2 Power supply module not detected	M-CCIEF-H	Power supply module in P2 slot is configured but not detected.
2011H	Non-Fatal	Additional power supply module detected	M-CCIEF-H	Additional power supply is detected.
2012H to 22FFH	Reserved			
230XH	Non-Fatal	Wire break /Sensor fault	IO modules	Sensor wire break detected at IO module. Here X is channel number
231XH	Non-Fatal	Wire break /Actuator fault	IO modules	Actuator/ output device open circuit/ short circuit detected. Here X is channel number
2320H to 2FFE H	Reserved			
2FFFH	Non-Fatal	Non-fatal fieldbus error	All header modules	Non-fatal fieldbus error detected. Mild station error detected at CC-Link IE Field basis network. Further diagnosis related to fieldbus can be monitored in header diagnostic area.
3601H	Non-Fatal	Parity Error	M-2R2, M-1R2 and M-1R4	Parity error occurs during reception
3602H	Non-Fatal	Framing Error		Framing error occurs during reception
3603H	Non-Fatal	Overrun Error		Overrun error occur during data reception
3604H	Non-Fatal	Modbus communication error	M-1R4	Error observed while communicating with one or more slaves

List of Info and Error messages





The table below provides list of info and error messages generated by [Modular IO Configurator](#) during operations like project creation, module deletion, project validation etc.

No	Message	Type of message	Validation stage
1	Start of header configuration check for: [Header No][Header name]	Info	Start Header configuration check
2	Starting 'Number of IO modules' check	Info	Number of IO modules check
3	Total number of IO modules in configuration: XX	Info	
4	Number of IO modules exceed maximum limit of NN modules Where NN is maximum number of modules allowed in header configuration. Device description file of selected header mentions about maximum number of modules allowed to connect to header.	Error	
5	End of 'Number of IO modules' check	Info	
6	Starting 'Unknown module' check	Info	
7	Unknown modules detected in slot n1, n2, n3, n4	Error	Unknown module check
8	Unknown modules are not detected	Info	
9	End of 'Unknown module' check	Info	
10	Starting 'Field power distribution' check	Info	
11	Field power distribution error detected at slot 'n'. Where 'n' is slot number where field power distribution error is detected.	Error	Field power distribution check
12	No field power distribution error detected.	Info	
13	End of field power distribution check	Info	
14	Starting 'System power consumption' check	Info	
15	System power consumption error detected at slot 'n'. Where 'n' is slot number where system power distribution error is detected.	Error	System power consumption check
16	No system power consumption error detected	Info	
17	End of system power consumption check	Info	
18	Starting 'Bus end module' check	Info	
19	No bus end module detected	Error	Bus termination module check
20	Bus end module detected	Info	
21	End of bus end module check	Info	
22	Starting 'Parameter' check	Info	
23	Checking parameters of [Slot No] [Module Name]	Info	Parameter check
24	Parameter value error at [Slot No] [Module Name]: invalid value for parameter [Parameter name]	Error	
25	Parameter check complete for [Slot No] [Module Name]	Info	
26	End of parameter check	Info	

27	Configuration data size exceeds maximum limit. Max size [Size] bytes	Error	Configuration data size check
28	Size of configuration data [Size] bytes	Info	
29	End of header configuration check for: [Header name]	Info	End Header configuration check
30	Errors:[Number of errors], Warnings: [Number of warnings]	Info	
31	Invalid configuration	Error	SD memory card
32	Invalid file format. Destination drive should be FAT32	Error	
33	Configuration file of selected header is already present, do you want to replace?	Warning	
34	Configuration file is not available in source drive.	Error	
35	Header ordering code[Ordering code] in configuration file is not matched with selected header	Error	
36	Header username [username] in configuration file is already present in project.	Error	
37	Configuration exceeded maximum limit.	Error	
38	Insufficient memory available in Destination drive.	Error	
39	Destination drive is not removable.	Error	
40	SD Card is not available.	Error	
41	Destination drive is not available.	Error	
42	Source drive is not removable.	Error	
43	Source drive is not available.	Error	
44	Start of SD Card Write	Info	
45	SD Card Write Successful	Info	
46	Start of SD Card Read	Info	
47	SD Card Read Successful	Info	

LED indications: States and flashing rates

The table below explains how LED states are sync with the flashing rates. This functionality is applicable to all modules covered in this manual.

Indication State	Description
Blinking fast	Equal ON and OFF time. Approximately 250ms. 
Blinking slow	Equal ON and OFF time. Approximately 500ms. 
Single Flash	One short single flash followed by long OFF time. Short ON Time = 250ms Long OFF Time :1000ms 
Double Flash	Two short flashes followed by long OFF time. Short ON Time = Short OFF time = 250ms Long OFF Time :1000ms 
Triple Flash	Two short flashes followed by long OFF time. Short ON Time = Short OFF time = 250ms Long OFF Time :1000ms 

Copyright © Mitsubishi Electric India Pvt. Ltd. 2020. All rights reserved.

The reproduction or transmission of this document or its contents in full or part is not permitted without express written authority. Offenders will be liable for damages. All rights, including rights created by patent grant or registration of a utility model or design, trademark is reserved.

Specifications subject to change without notice.

MITSUBISHI ELECTRIC INDIA PRIVATE LIMITED

Factory Automation and Industrial Division (FAID)

ICC-Devi Gaurav Technology Park, Unit No. 402,

Opp. Vallabh Nagar Bus Depot,

Pune-411018, Maharashtra, India.

Email – MEI-FAID-INFO@asia.meap.com

Tel.: +91-20-2710 2000 | **Fax:** +91-20-2710 2100

Learn more at <http://in.mitsubishielectric.com>